

TESS

expert

PHYWE

Demo

expert

PHYWE

Eng

Geo

JAN. 2013

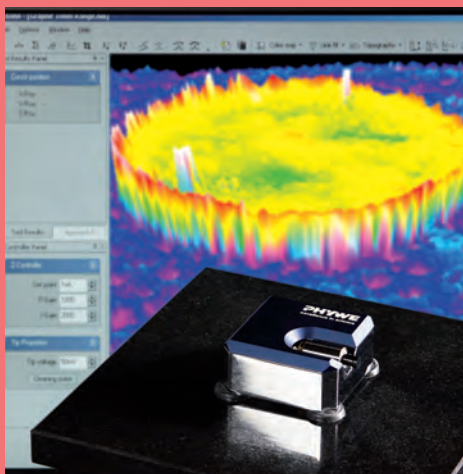

Engineering/Geo Science

University Experiments

Materials Science and Engineering: Curricula Compliant Experiments – for your educational needs

PHYWE™ experiments have been matched to the curricula of more than 30 selected universities worldwide. The interaction between PHYWE's experiments and the supporting content of experimental lectures and lab courses has led to the creation of a teaching package that is highly relevant to the curriculum worldwide.



Materials Science and Engineering Bachelor of Science Course – Reference Curriculum

Content	1. Sem.	2. Sem.	3. Sem.	4. Sem.	5. Sem.	6. Sem.
Laboratory Experiments	General Physics*		Electrical Engineering (Chapter 5)		Material Analysis and Testing (e.g. NDT) (Chapter 4)	
	General and Inorganic Chemistry**		Physical Chemistry**	Crystallography (Chapter 3)	Thermochemistry**	
		Materials Science 1 (Chapter 3)	Materials Science 2 (Chapter 3)			
Lecture, Tutorial, Experiments	General Physics*		Electrical Engineering (Chapter 5)		Solid State Physics*	
	Materials Science 1 (Chapter 3)		Materials Science 2 (Chapter 3)		Material Analysis and Testing (e.g. NDT) (Chapter 4)	
	General and Inorganic Chemistry**		Physical Chemistry**	Organic Chemistry**	Electrochemistry**	
			Crystallography (Chapter 3)		Thermochemistry**	
Elective Subject			e.g. Metals, Polymers, Ceramics, Biomaterials		e.g. Nanotech., Renew. Energy, Electr. Devices, Photonics (Chap. 5,6,7)	
Theoretical Courses	Mathematics		Computer Sciences and Engineering		Measurement Technology	
			Technical Mechanics		Design and Construction	Business Administration and Industrial Management
Interships			Industrial Internship		Research Internship	
Bachelor Thesis						Bachelor Thesis

More than 80% of the experimental courses are covered by PHYWE experiments!

■ PHYWE Experiments available in this catalogue
 ■ * Please refer to TESS expert Physics catalogue
 ■ ** Please refer to TESS expert Chemistry catalogue

Geo Science: Curricula Compliant Experiments – multidisciplinary education with PHYWE

Geo science is one of the most multidisciplinary subjects taught in natural sciences. The first semesters or introductory courses cover general topics in physics, chemistry and biology followed by classical topics of geo science such as: geology, petrology, palaeontology, mineralogy, environment (climate, soil, water), spectroscopy, or X-ray analyses. Find corresponding experiments in this catalogue or refer to our TESS expert and Demo expert catalogues Physics, Chemistry or Biology.

Geo Science

Bachelor of Science Course – Reference Curriculum

Content	1. Sem.	2. Sem.	3. Sem.	4. Sem.	5. Sem.	6. Sem.
Laboratory Experiments	General Chemistry**		Optics and Microscopy***	Water: Cycle and Quality (Chapter 8.1)	General Biology***	Ore Microscopy, Nanoimaging (Chapter 3)
	General Physics*		Geochemistry	Soil Science (Chapter 8.3)	Mineralogy and Crystallography (Chapter 4.1)	Elementary Analysis/ Spectroscopy (e.g. XRF) (Chapter 4.1, 8.4)
Lecture, Tutorial, Experiments		Introductory Geology	Mineralogy and Petrology	Geophysics	Geocology (Chapter 8)	Petrology / Petro-chemistry**
Elective Subject		Metallurgy**	Atmosphere: Science, Climate, and Change (Chapter 8.2)	Meteorology	Water: Hydrogeology, Hydrochemistry**	X-ray Powder Diffraction Laboratory (Chapter 8.9)
Theoretical Courses	Mathematics		Palaeontology	Sedimentation	Digital Mapping	
	Geology	Mineralogy	Sedimentary/ Igneous	Petrology	Geomorphology	Meteorology, Climatology
Field Studies	e.g. Field Mapping		e.g. Landscape Evolution and Analysis		e.g. Environmental Geology	
Bachelor Thesis						Bachelor Thesis

More than 60% of the experimental courses are covered by PHYWE experiments!

 PHYWE Experiments available in this catalogue.

 * Please refer to TESS expert Physics catalogue

 ** Please refer to TESS expert Chemistry catalogue

 *** Please refer to TESS expert Biology catalogue



TESS expert and Demo expert Physics

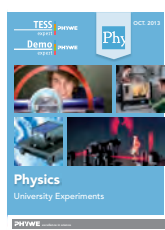

TESS expert and Demo expert Chemistry / Pharmacy



TESS expert and Demo expert Biology



TESS expert Engineering and Geo Science

1	Table of contents	2
2	Applied Mechanics	13
3	Materials Science	43
4	Non-destructive Testing (NDT)	79
5	Electrical Engineering	107
6	Renewable Energy	141
7	Photonics	165
8	Geo Science	193
9	About PHYWE	217
10	Indices	233

How to use

the table of contents

Use the curricula-based content on the next pages to find your topics and our corresponding experiments. The TESS expert catalogue is adapted to international university curricula making it easy for you to find experiments corresponding to your desired topic. On each page you find the detailed description of one of our university level experiments. More information including the complete experiment description is available on our website www.phywe.com.

Overview TESS expert		
2 Applied Mechanics		
2.1 Statics		
P2120200	Modulus of elasticity	14
P2120300	Mechanical hysteresis	15
P2120100	Moments	16
P1253500	Torque	16
P2133000	Torsional vibrations and torsion modulus	17
P5160900	Shear waves in solid state materials	18
P2130160	Hooke's law (with Cobra4)	19
P2130101	Hooke's law	19
2.2 Dynamics		
P2131500	Moment and angular momentum	20
P2131305	Moment of inertia and angular acceleration with a precision pivot bearing	21
P2131301	Moment of inertia and angular acceleration and with an air bearing	21
P2131311	Moment of inertia and angular acceleration with Cobra3 and with an air bearing	21
P2131315	Moment of inertia and angular acceleration with Cobra3 and with an air bearing	21

Curricular topic = main chapter of the catalogue

Curricular subtopic = sub-chapter of the catalogue

Curricular fitting PHYWE experiments

Find the overview of all experiments fitting to the international reference curriculum on our homepage!
Click www.phywe.com



2 Applied Mechanics

2.1 Statics		
P2120200	Modulus of elasticity	14
P2120300	Mechanical hysteresis	15
P2120100	Moments	16
P1253500	Torque	16
P2133000	Torsional vibrations and torsion modulus	17
P5160900	Shear waves in solid state materials	18
P2130160	Hooke's law (with Cobra4)	19
P2130101	Hooke's law	19
2.2 Dynamics		
P2131500	Moment and angular momentum	20
P2131305	Moment of inertia and angular acceleration with a precision pivot bearing	21
P2131301	Moment of inertia and angular acceleration and with an air bearing	21
P2131311	Moment of inertia and angular acceleration and with an air bearing (with Cobra3)	21
P2131315	Moment of inertia and angular acceleration and a precision pivot bearing (with Cobra3)	21
P2131360	Moment of inertia and angular acceleration (with Cobra4)	21
P2133100	Moments of inertia and torsional vibrations	22
P2132801	Moment of inertia / Steiner's theorem	22
P2132660	Harmonic oscillations of spiral springs - Spring linked in parallel and series (with Cobra4)	23
P2132701	Forced oscillations - Pohl's pendulum	24
P2132760	Forced oscillations - Pohl's pendulum (with Cobra4)	24
P2131900	Laws of gyroscopes / 3-axis gyroscope	25
P2132000	Laws of gyroscopes / cardanic gyroscope	26
14440-62	Software "Measure Dynamics", campus licence	27
2.3 Fluidynamics and Aerodynamics		
P2140100	Density of liquids	28
P2140200	Surface of rotating liquids	29
P2140300	Viscosity of Newtonian and non-Newtonian liquids (rotary viscometer)	30
P2140400	Viscosity measurement with the falling ball viscometer	31
P2140500	Surface tension with the ring method (Du Nouy method)	32
P2140700	Barometric height formula	33

P2260511	LDA - laser Doppler anemometry with optical base plate (with Cobra3)	34
P2260560	LDA - Laser Doppler Anemometry (with Cobra4)	34
P5140100	Mechanics of flow	35
P5142100	Flow Measurement Ultrasonic Doppler effect	35
P5141100	Level measurement	36
P2151000	Optical determination of the velocity of sound in liquids	37
P2151100	Phase and group velocity of ultrasound in liquids	38
P2151200	Temperature dependence of the velocity of ultrasound in liquids	38
P2150305	Velocity of sound in air with Universal Counter	39
P2150605	Velocity of sound using Kundt's tube and digital function generator	40
P2150601	Velocity of sound using Kundt's tube	40
P2150405	Acoustic Doppler effect with universal counter	41
P2152415	Ultrasonic Doppler effect (with Cobra3)	42
P2152460	Ultrasonic Doppler effect (with Cobra4)	42

3 Materials Science

3.1 Mechanical Properties		
P5160900	Shear waves in solid state materials	44
P2133000	Torsional vibrations and torsion modulus	45
P2120300	Mechanical hysteresis	45
P2120200	Modulus of elasticity	46
P2120100	Moments	46
P2130160	Hooke's law (with Cobra4)	46
3.2 Magnetic Properties		
P2430760	Ferromagnetic hysteresis (with Cobra4)	47
P1221300	Ferromagnetism, paramagnetism and diamagnetism	47
P2430800	Magnetostriction with the Michelson interferometer	48
P2538500	Investigate in magnetic micro and nano structures by Magnetic Force Microscopy (MFM)	49
3.3 Thermal and Electrical Properties		
P2310100	Thermal expansion in solids and liquids	50
P2310200	Thermal expansion in solids	50
P2310300	Thermal expansion in liquids	50
P2330101	Heat capacity of metals	51
P2330160	Heat capacity of metals (with Cobra4)	51

P2350200	Thermal and electrical conductivity of metals	52
P2410460	Temperature dependence of different resistors and diodes (with Cobra4)	53
P2410401	Temperature dependence of different resistors and diodes with a multimeter	53
P2530300	Hall effect in metals	54
P2530101	Hall effect in p-germanium	55
P2530160	Hall effect in p-germanium (with Cobra4)	55
P2530260	Hall effect in n-germanium (with Cobra4)	55
P2530201	Hall effect in n-germanium	55
P2260106	Faraday effect with optical base plate	56
P2260100	Faraday effect	56
P2420600	Dielectric constant of different materials	57
3.4 X-ray Structural Analysis		
P2541301	Examination of the structure of NaCl monocrystals with different orientations	61
P2541401	X-ray investigation of cubic crystal structures / Debye- Scherrer powder method	62
P2541501	X-ray investigation of hexagonal crystal structures / Debye-Scherrer powder method	62
P2541602	X-ray investigation of crystal structures / Laue method with digital X-ray image sensor (XRIS)	63
P2541601	X-ray investigation of crystal structures / Laue method	63
3.5 X-ray Fluorescence Analysis		
P2544701	Qualitative X-ray fluorescence analysis of powder samples	64
P2545001	Quantitative X-ray fluorescence analysis of alloyed materials	65
P2545101	Quantitative X-ray fluorescence analysis of solutions	66
P2544501	Qualitative X-ray fluorescence spectroscopy of metals - Moseley's law	66
P2544601	Qualitative X-ray fluorescence analysis of alloyed materials	66
3.6 Nanotechnology		
09600-99	Compact-Scanning Tunneling Microscope (STM)	67
P2532000	Atomic Resolution of the graphite surface by STM (Scanning Tunnelling Microscope)	68
P2532500	Investigate in surface atomic structures and defects of different samples by STM	68
P2535000	Quantum Mechanics by STM - Tunneling Effect and Charge Density Waves	68

P2536000	Imaging and characterization of carbon-nanoarticle by STM (and STS)	68
P2534500	Self-assembled molecular networks of TMA and hexadecanol by STM	69
P2534000	Self-assembled molecular networks of arachin acid by STM	69
P2537000	Roughness and nanomorphology of different metal samples by STM	70
09700-99	Compact-Atomic Force Microscope (AFM)	71
P2538000	Basic methods in imaging of micro and nanostructures with atomic force microscopy (AFM)	72
P2538400	Imaging of biological and medical micro and nanostructure with atomic force microscopy (AFM)	73
P2538100	Basic methods in force spectroscopy to investigate material characteristics with atomic force microscopy (AFM)	74
P2538200	Using the phase contrast mode to distinguish between different materials on the nano scale - Material contrast with AFM	75
P2538500	Investigate in magnetic micro and nanostructures by Magnetic Force Microscopy (MFM)	76
3.7 Metallography		
P5510100	Metallographic sample preparation - grinding and polishing	77
P5510200	Metallographic sample preparation - chemical etching	78

4 Non-destructive Testing (NDT)

4.1 X-ray Investigations		
P2542001	Determination of length and position of an object which can not be seen	82
P2542701	Debye-Scherrer diffraction measurements for the examination of the texture of rolled sheets	83
P2540010	Counter tube characteristics	83
P2545001	Quantitative X-ray fluorescence analysis of alloyed materials	84
P2545101	Quantitative X-ray fluorescence analysis of solutions	84
P2545201	X-ray fluorescence spectroscopy / layer thickness determination	85
P2550100	Computed tomography	86
09110-88	XRE 4.0 X-ray expert set	87
09180-88	XRCT 4.0 X-ray Computed Tomography upgrade set	87
09057-40	XR 4.0 X-ray Direct Digital Image Sensor (XRIS) with USB cable	88

09057-42	XR 4.0 X-ray CT Z-rotation stage (XRstage)	88
14421-61	XR 4.0 Software measure CT	88
P2550300	Principles of beam intensity	89

4.2 Ultrasonic Testing

P5160100	Velocity of ultrasound in solid state material	90
P5160200	Ultrasonic echography (A-Scan)	91
P5160300	Ultrasonic echography (B-Scan)	92
P5160400	Angle beam measurement	93
P5160500	Time of flight diffraction (TOFD)	94
P5160600	Detection of discontinuities	95
P5160700	Frequency dependence of resolution power	96
P5160800	Attenuation of ultrasound in solid state materials	97
P5160900	Shear waves in solid state materials	98
P5161000	Determination of the focus zone	99
P5161100	Mechanical scan methods	100
P5161200	Ultrasonic computertomography	101

4.3 Other Methods of NDT

P2538000	Basic methods in imaging of micro and nanostructures with atomic force microscopy (AFM)	102
P2538100	Basic methods in force spectroscopy to investigate material characteristics with atomic force microscopy (AFM)	102
P2538200	Using the phase contrast mode to distinguish between different materials on the nano scale - Material contrast with AFM	102
P2538500	Investigate in magnetic micro and nanostructures by MagneticForce Microscopy (MFM)	102
P2532500	Investigate in surface atomic structures and defects of different samples by STM	103
P2537000	Roughness and nanomorphology of different metal samples using by STM	103
P2150501	Chladni figures	104
P2220900	Michelson interferometer - High Resolution	105
P2260305	Transfer hologram from a master hologram	106

5 Electrical Engineering

5.1 Preparatory Courses

15265-88	TESS advanced Physics Electricity / Electronics Building Block System, Basic Set Electricity	108
----------	--	-----

15266-88	TESS advanced Physics Electricity/Electronics Building Block System, supplementary set Electromagnetism and Induction	108
15267-88	TESS advanced Physics Electricity/Electronics Building Block System, supplementary set Electronics	108
13470-88	TESS advanced Electronics necessary accessories for 1 group	108
01006-02	TESS Physics manual Electric/Electronic Building Block System, Part 1 and 2	108
01054-00	Software interTESS Physics, Electrics / Electronics, DVD	108
15221-88	TESS advanced Physics set Electric motor/Generator	109
15250-88	TESS advanced Physics set Equipotential lines and electric fields	109
13411-88	TESS advanced Equipotential lines necessary accessories for 1 group	109
13029-02	TESS advanced Physics manual Equipotential lines and Electric field	109
01055-00	Software interTESS Physics, Electrostatics / Magnetism, Equipotential lines, DVD	109
07880-02	TESS advanced Physics manual Electric Motor / Generator	109
13412-88	TESS advanced Electric Motor / Generator EMG necessary accessories for 1 group	109
30505-77	Electrochemical measurement set	110
01194-02	TESS advanced manual Electrochemical measurement set	110
13230-77	TESS advanced Physics set Magnetism, MAG	110
01162-02	TESS advanced Physics manual Magnetism	110
01055-00	Software interTESS Physics, Electrostatics / Magnetism, Equipotential lines, DVD	110
13422-88	TESS advanced Chemistry Electrochemical measurement set EC necessary accessories for 1 group	110

5.2 Properties of Electrical Devices

P2410960	Characteristic curves of semiconductors (with Cobra4)	111
P2410460	Temperature dependence of different resistors and diodes (with Cobra4)	112
P2410401	Temperature dependence of different resistors and diodes with a multimeter	112
P2420600	Dielectric constant of different materials	113
P2420100	Electric fields and potentials in the plate capacitor	113
P2420201	Charging curve of a capacitor / charging and discharging of a capacitor	114

P2420715	Switch-on behaviour of a capacitor and an inductance with the FG module (with Cobra3)	115
P2420760	Switch-on behaviour of a capacitor and an inductance with the FG module (with Cobra4)	115
P2440501	Capacitor in the AC circuit	116
P2440560	Capacitor in the AC circuit (with Cobra4)	116
P2440401	Coil in the AC circuit	117
P2440460	Coil in the AC circuit (with Cobra4)	117
P2430260	Magnetic field of single coils/ Biot-Savart's law (with Cobra4)	118
P2430201	Magnetic field of single coils/ Biot-Savart's law with a teslameter	118
P2441211	Induction impulse (with Cobra3)	119
P2441260	Induction impulse (with Cobra4)	119
P2440260	Magnetic Induction (with Cobra4)	120
P2440201	Magnetic induction	120
P2440301	Inductance of solenoids	121
P2440360	Inductance of solenoids (with Cobra4)	121
P2441101	Resistance, phase shift and power in AC circuits with digital function generator	122
P2440100	Transformer	123
P2530300	Hall effect in metals	124
P2530101	Hall effect in p-germanium	125
P2530201	Hall effect in n-germanium	125
P2530160	Hall effect in p-germanium (with Cobra4)	125
P2530260	Hall effect in n-germanium (with Cobra4)	125
P2530401	Band gap of germanium	126
P2530460	Band gap of germanium (with Cobra4)	126
P2530411	Band gap of germanium (with Cobra3)	126
P3060962	Nernst equation (with Cobra4)	127
P3061262	Temperature dependence of the electromotive force (with Cobra4)	128
P2411360	Second order conductors. Electrolysis (with Cobra4)	129
P2410700	Semiconductor thermogenerator - Seebeck effect	130
5.3 Properties of Electrical Circuits		
P2410160	Ohm's law (with Cobra4)	131
P2410560	Kirchhoff's laws (with Cobra4)	132
P2410500	Kirchhoff's laws	132
P2410101	4 Point Method / Measurement of low resistances / Ohm's Law	133
P2441005	RLC measuring bridge	134
P2410200	Wheatstone bridge	134
P2440601	RLC circuit	135

P2440660	RLC circuit (with Cobra4)	135
P2440700	Rectifier circuits	136
P2440801	RC filters	137
P2440905	High-pass and low-pass filters with digital function generator	138
P2440960	High-pass and low-pass filters (with Cobra4)	138
P2440915	High-pass and low-pass filters with the FG module (with Cobra3)	138
P2450201	Coupled resonant circuits	139
P2450301	Forced oscillations of a nonlinear electrical series resonant circuit - chaotic oscillation (with Cobra3)	140
P2450360	Forced oscillations of a nonlinear electrical series resonant circuit - chaotic oscillation (with Cobra4)	140

6 Renewable Energy

6.1 Preparatory Courses

09492-88	Demo Applied Sciences Set Renewable Energy ENT1	142
09493-88	Demo Applied Sciences Set Renewable Energy ENT2	142
01157-02	Demo advanced Applied Sciences manual Renewable Energy on the magnetic board	142
12608-88	Cobra4 wireless, extension set for renewable energy: electric parameters, temperature	142

6.2 Basic Principles

P2350200	Thermal and electrical conductivity of metals	143
P3010701	Thermal conductivity of gases	144
P2320201	Heat capacity of gases	145
P1043960	Specific heat capacity of water (with Cobra4)	145
P2330160	Heat capacity of metals (with Cobra4)	145
P2320260	Heat capacity of gases (with Cobra4)	145
P2330101	Heat capacity of metals	146
P2330160	Heat capacity of metals (with Cobra4)	146
P2330200	Mechanical equivalent of heat	147
P2330260	Mechanical equivalent of heat (with Cobra4)	147
P3011160	Gay-Lussac's law (with Cobra4)	148
P3011260	Amontons' law (with Cobra4)	148
P3011360	Boyle's law (with Cobra4)	148

P3021701	Determination of the heating value of fuel oil and of the calorific value of olive oil	149
P3021401	Determination of the enthalpy of combustion with a calorimetric bomb	150
P2410960	Characteristic curves of semiconductors (with Cobra4)	151
P2410460	Temperature dependance of different resistors and diodes (with Cobra4)	151
P2530111	Hall effect in p-germanium (with Cobra3)	151
P2440100	Transformer	152
P2420201	Charging curve of a capacitor / charging and discharging of a capacitor	152
P2420715	Switch-on behaviour of a capacitor and an inductance with the FG module (with Cobra3)	152
P2420600	Dielectric constant of different materials	153
P2420100	Electric fields and potentials in the plate capacitor	153
P3060962	Nernst equation (with Cobra4)	153
6.3 Heat		
P2360360	Heat insulation / heat conduction	154
P2360200	Electric compression heat pump	155
13715-93	Work and power meter	155
P2410800	Peltier heat pump	156
P2410700	Semiconductor thermogenerator - Seebeck effect	157
P2360401	Stirling engine with an oscilloscope	158
P2360460	Stirling engine (with Cobra4)	158
6.4 Solar Energy		
P2350101	Stefan-Boltzmann's law of radiation with an amplifier	159
P2350160	Stefan-Boltzmann's law of radiation (with Cobra4)	159
P2360100	Solar ray collector	160
P2410901	Characteristic curves of a solar cell	161
6.5 Hydrogen Technology		
P2411200	Faraday's law	162
P3021501	Determination of the heat of formation of water	163
P2411100	Characteristic curve and efficiency of a PEM fuel cell and a PEM electrolyser	164

7 Photonics

7.1 Basic Principles

P2240405	Lambert's law of radiation on optical base plate	166
P2240400	Lambert's law	166
P2250105	Polarisation through quarter-wave plates with optical base plate	167
P2250100	Polarisation through quarter-wave plates with optical profile bench	167
P2250305	Fresnel's law - theory of reflection with optical base plate	168
P2250300	Fresnel's equations - theory of reflection with optical profile bench	168
P2230105	Diffraction at a slit and Heisenberg's uncertainty principle with optical base plate	169
P2230100	Diffraction at a slit and Heisenberg's uncertainty principle with optical bench	169
P2230405	Diffraction of light through a double slit or by a grid with optical base plate	170
P2230400	Diffraction intensity due to multiple slits and grids with optical profile bench	170
P2230605	Diffraction intensity at a slit and at a wire - Babinet's theorem with optical base plate	171
P2230600	Diffraction intensity at a slit and at a wire - Babinet's theorem with optical profile bench	171
P2220205	Newton's rings with optical base plate	172
P2220200	Newton's rings with interference filters	172
P2250505	Polarimetry with optical base plate	173
P2250200	Polarimetry	173
P2260106	Faraday effect with optical base plate	174
P2260100	Faraday effect with optical profile bench	174
P2261100	Fourier optics - 2f arrangement	175
P2261200	Fourier optics - 4f arrangement - filtering and reconstruction	176
P2260511	LDA - laser Doppler anemometry with optical base plate (with Cobra3)	177
P2260560	LDA - laser Doppler anemometry (with Cobra4)	177
7.2 Interferometry		
P2220505	Michelson interferometer with optical base plate	178
P2220500	Michelson interferometer with optical profile bench	178
P2220705	Refraction index of CO ₂ with the Michelson interferometer with optical base plate	179

P2220700	Refraction index of air and CO ₂ with the Michelson interferometer with optical profile bench	179
P2220900	Michelson interferometer - High Resolution with optical base plate	180
P2221305	Twyman-Green interferometer	180
P2430800	Magnetostriction with the Michelson interferometer	181
P2221000	Doppler effect with the Michelson interferometer with optical base plate	182
P2221100	Refraction index of air with the Mach-Zehnder interferometer with optical base plate	183
P2220800	Quantum eraser	184
P2221205	Fabry-Perot interferometer - determination of the wavelength of laser light on optical base plate	185
P2221206	Fabry-Perot interferometer - optical resonator modes	186
7.3 Holography		
P2260300	Recording and reconstruction of holograms with optical base plate	187
P2260305	Transfer hologram - master hologram	188
P2260306	Holography - Real time procedure	188
7.4 Laser		
P2260701	Helium neon laser, basic experiment	189
P2260705	Helium neon laser, advanced experiment	189
P2260800	Optical pumping	190
P2260900	Nd:YAG laser	191
7.5 Fibre Optics		
P2261000	Fibre optics	192

8 Geo Science

8.1 Water		
P4100160	Comparison of the heat capacities of water and soil (with Cobra4)	194
P4100560	Conductivity of various water samples (with Cobra4)	195
P4100760	The origin of acid rain (with Cobra4)	196
8.2 Air		
P2140700	Barometric height formula	200
8.3 Soil		
P1521163	Salinity of soils and plant substrates (with Cobra4)	201
P1521063	The pH value of various soils (with Cobra4)	202

8.4 X-ray Analysis		
P2541301	Examination of the structure of NaCl monocrystals with different orientations	207
P2541401	X-ray investigation of cubic crystal structures / Debye-Scherrer powder method	208
P2541501	X-ray investigation of hexagonal crystal structures / Debye-Scherrer powder method	208
P2541602	X-ray investigation of crystal structures / Laue method with digital X-ray image sensor (XRIS)	209
P2541601	X-ray investigation of crystal structures / Laue method	209
P2544701	Qualitative X-ray fluorescence analysis of powder samples	210
P2545001	Quantitative X-ray fluorescence analysis of alloyed materials	211
P2544901	Qualitative X-ray fluorescence analysis of ore samples	212
P2544501	Qualitative X-ray fluorescence spectroscopy of metals - Moseley's law	213
P2545101	Quantitative X-ray fluorescence analysis of solutions	214
P2544601	Qualitative X-ray fluorescence analysis of alloyed materials	214
8.5 Literature		
12622-02	TESS advanced Applied Sciences manual Cobra4 environment and outdoors	215
01200-02	Handbook Physics X-Ray Experiments	216

How to use

Facts about the TESS expert catalogue

The TESS expert catalogue is adapted to the PHYWE reference curriculum. PHYWE's experiments fit to the content of experimental lectures and lab courses of schools, colleges and universities. The description of each experiment offers you a lot of information:

3 Material Sciences
 3.2 Magnetic Properties

Article number

Ferromagnetic hysteresis (with Cobra4) P2430760

Pictograms for quick overview

Experimental setup



Exemplary measurement result

Description of main principle

Principle
 A magnetic field is generated in a ring-shaped iron core by a continuous adjustable direct current applied to two coils. The field strength I and the flux density B are measured and the hysteresis recorded. The remanence and the coercive field strength of two different iron cores can be compared.

Task
 Record the hysteresis curve for a massive iron core and for a laminated one.

What you can learn about

- Induction
- Magnetic flux
- Coil
- Magnetic field strength
- Magnetic field of coils
- Remanence
- Coercive field strength

Variations of the main experiment (e.g. the same experiment with PC-interface) and experiments with similar topics

Tasks for students

Related Experiment
 Ferromagnetism, paramagnetism and diamagnetism
 P1223100

Cobra4 Sensor Tesla, magnetic field strength, resolution max. ± 0.01 mT



Devices suitable for the experiment

Related scientific topic

Main articles

Cobra4 Wireless Manager	12600-90	1
Cobra4 Wireless-Link	12601-00	2
Cobra4 Sensor Tesla, magnetic field strength, resolution max. ± 0.01 mT	12652-00	1
Cobra4 Sensor-Unit Electricity, Current ≤ 6 A / Voltage ≤ 30	12644-00	1
Software Cobra4 - multi-user interface	14550-01	1
Power supply, universal	13500-93	1
Half probe, tangential, protection cap	13610-02	1

Function and Applications
 Sensor out of the Cobra4 family to measure the magnetic field strength in DC and AC fields. This Sensor is suitable for the connection of the Hall probes.

Benefits

- Connection of two different Hall probes possible: tangential and axial
- Exceptionally good resolution
- Measurement of the earth's magnetic field possible

List of main articles
 Complete list see: www.phywe.com

PHYWE Systeme GmbH & Co. KG · www.phywe.com

49

Pictograms for a quick overview of categories, related films or information:

	Experiments with the Computer based measuring system Cobra4		Demonstration experiments		Experiments with laser
	Experiments which have received a Nobel Prize		Computer based measuring		Experiments with radioactivity
	Product movie available - click at www.phywe.com		New and completely revised experiments		Training recommended

Didactic literature –

comprehensive guide for every experiment

Extensive experimental literature is available for all our university level experiments. Rely on the advantages of our TESS expert experiment descriptions:

- All experiments are uniformly built up
- Experiments cover the entire range of classical and modern chemistry
- Didactically adapted descriptions – enables direct preparation by the student
- Developed and proven by practitioners – comfortable and reliable performance
- Excellent measurement accuracy – results agree with theory
- Computer-assisted experiments – easy, rapid assessment of results
- Modular experimental set-up – multiple use of individual devices, cost effective and flexible

TESS expert | **Detection of discontinuities** | TEAS 1.6.06 -00

Related topics
Ultrasonic echography, discontinuity, A-Mode, straight beam probe, angle beam probe, angle, signal-to-noise ratio.

Principle
The experiment demonstrates the application and performance of various non-destructive detection methods. First, the test object is scanned in order to determine which is most suitable for which type of defect. Then, the signal-to-noise-ratio is determined for a straight beam probe, angle beam probe, and a transmitter-receiver probe (TR probe) by a discussion of the results in view of the selection of the most suitable detection task.

Equipment

1 Basic Set "Ultrasonic Echoscope" consisting of: <ul style="list-style-type: none">1x Ultrasonic echoscope1x Ultrasonic probe 1 MHz1x Ultrasonic probe 2 MHz1x Ultrasonic test block1x Ultrasonic cylinder set1x Ultrasonic test plates1x Ultrasonic gel	13921-99
1 Extension set: Non-destructive testing	13921-01
1 Ultrasonic probe 2 MHz	13921-05

Additional equipment:
PC with a USB port, Windows XP or higher

Fig. 1: Detection of discontinuities: experimental set-up

TESS expert | **Detection of discontinuities** | TEAS 1.6.06 -00

Fig. 5: Measurement of the noise amplitude at the vertical crack with the straight beam probe

It has a low amplitude even if the discontinuity does not produce an echo like the vertical cylinder or oblique crack, for example. In this respect, the bottom echo can be very helpful for the analysis of test objects provided that the test objects have suitable geometrical shapes that enable the evaluation of the bottom echo.

- Save the sectional image and switch back to the "A-mode".
- Now, measure the signal amplitude and the noise amplitude of each of the discontinuities (Fig. 4 and 5). To do so, position the probe at a discontinuity and determine the maximum signal amplitude. Ensure that it is actually the signal of the discontinuity in question in order to avoid misinterpretations. The upper end of the oblique crack, for example, displays a very strong reflection signal. This, however, has nothing to do with the reflection on the oblique surface, which is why it must not be interpreted as an echo at the oblique crack.
- In order to perform the measurement, move the horizontal measurement cursor to the maximum of

Fig. 6: Sectional image of the test object with the angle beam probe (tip pointing in the scanning direction)

Picture, Equipment list and Instruction for the execution of the experiment guarantee easy conduction of the experiment.

Theory and evaluation includes full theory of the experiment and shows graphical and numerical experimental results.

Your solution with just one click!



Our comprehensive Internet site **www.phywe.com** provides you with all the information you need covering the full spectrum of solutions and products from PHYWE – in five languages! Whether your specific needs involve physics, chemistry, biology or applied sciences, and whether you are looking for information relating to school or university-level materials, you can always find just the right products there quickly and easily.

Further highlights on our website include:

- More than 50 product videos
- Complete assembly instructions in video form
- Up-to-date software downloads
- Free-of-charge descriptions of the experiments
- Operating manuals and instruction sheets to download

- 1 Language
- 2 Subject area = Physics, Chemistry, Biology, Applied Sciences
- 3 Education level = School, University
- 4 Media e. g. product videos
- 5 Downloads e. g. experimental literature



Visit us today: www.phywe.com



Cooperations – Reliable partner for education

There's a way to do
it better – find it.

Thomas Edison

The share of ideas and transfer of knowledge between academia and PHYWE is one of our major attempts in R&D. Our network is spread out worldwide and comprises cooperation projects, research assignments, and the education of expert staff.

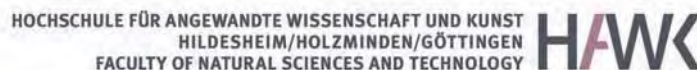

Some breathtaking novelties of our new XR 4.0 platform are one by one the result of fruitful cooperation in this regard - thank you!

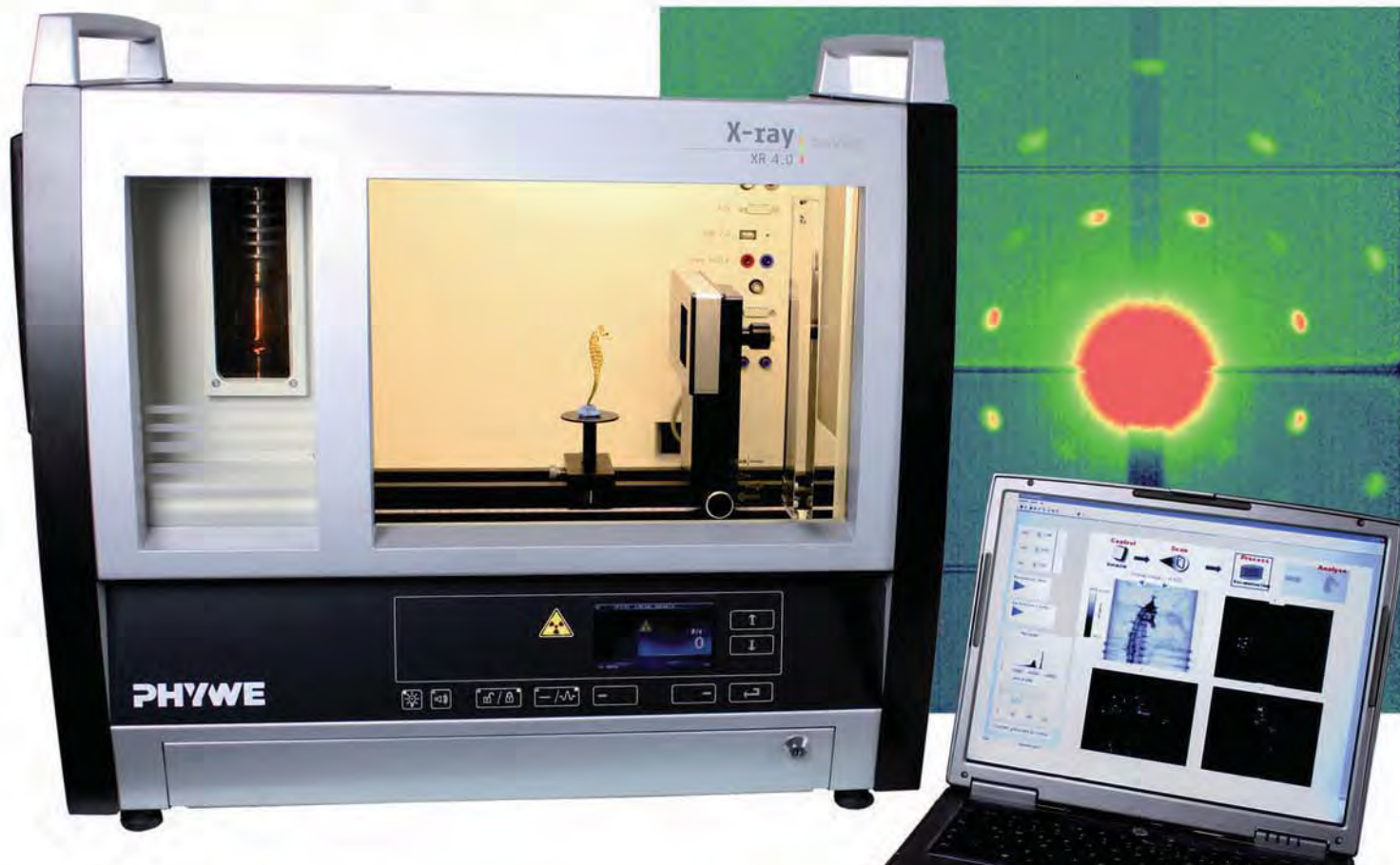
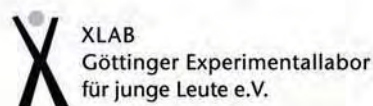



Applied Mechanics

2.1	Statics	14
2.2	Dynamics	20
2.3	Fluidynamics and Aerodynamics	28

P2120200 Modulus of elasticity

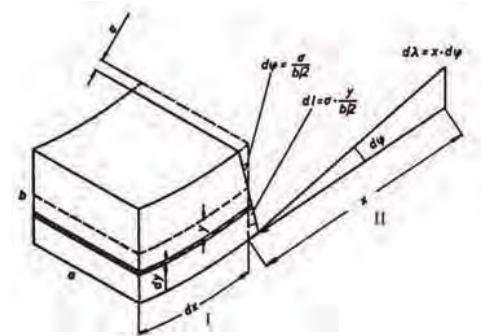

Deformation of a bar.

Principle

A flat bar is supported at two points. It is bent by the action of a force acting at its centre. The modulus of elasticity is determined from the bending and the geometric data of the bar.

Tasks

1. Determination of the characteristic curve of the dial gauge.
2. Determination of the bending of flatbars as a function of the force; at constant force: of the thickness, of the width and of the distance between the support points.
3. Determination of the modulus of elasticity of steel, aluminium and brass.

What you can learn about

- Young's modulus
- Modulus of elasticity
- Stress
- Deformation
- Poisson's ratio
- Hooke's law

Main articles

Flat bars, set	17570-00	1
Dial gauge 10/0.01 mm	03013-00	1
Tripod base PHYWE	02002-55	2
Holder for dial gauge	03013-01	1
Knife-edge with stirrup	03015-00	1
Spring Balance 1 N	03060-01	1
Vernier caliper	03010-00	1



Mechanical hysteresis

P2120300

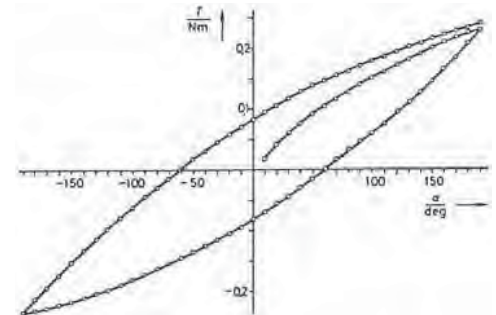

Mechanical hysteresis curve for the torsion of a copper rod of 2 mm diameter and 0.5 m long.

Principle

The relationship between torque and angle of rotation is determined when metal bars are twisted. The hysteresis curve is recorded.

Tasks

1. Record the hysteresis curve of steel and copper rods.
2. Record the stress-relaxation curve with various relaxation times of different materials.

What you can learn about

- Mechanical hysteresis
- Elasticity
- Plasticity
- Relaxation
- Torsion modulus
- Plastic flow
- Torque
- Hooke's law

Main articles

Torsion apparatus	02421-00	1
Spring Balance 1 N	03060-01	1
Spring balance 2,5 N	03060-02	1
Torsion rod, Al, l = 500 mm, d = 4 mm	02421-06	1
Torsion rod, Al, l = 500 mm, d = 3 mm	02421-05	1
Torsion rod, Cu, l = 500 mm, d = 2 mm	02421-08	1
Torsion rod, steel, l = 500 mm, d = 2 mm	02421-01	1

Torsion apparatus, complete



Function and Applications

To investigate deformations due to torques. For demonstration of the combined effects of force and lever.

02421-88

You need more information?
Just click www.phywe.com

WEB@ PHYWE



P2120100 Moments

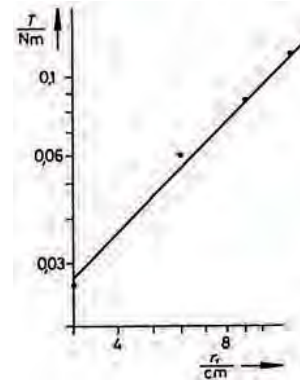

Moment as a function of the distance between the origin of the coordinates and the point of action of the force.

Principle

Coplanar forces (weight, spring balance) act on the moments disc on either side of the pivot. In equilibrium, the moments are determined as a function of the magnitude and direction of the forces and of the reference point.

Tasks

1. Moment as a function of the distance between the origin of the coordinates and the point of action of the force.
2. Moment as a function of the angle between the force and the position vector to the point of action of the force.
3. Moment as a function of the force.

What you can learn about

- Moments
- Couple
- Equilibrium
- Statics
- Lever
- Coplanar forces

Main articles

Moments disk	02270-00	1
Tripod base PHYWE	02002-55	2
Spring Balance 1 N	03060-01	2
Barrel base PHYWE	02006-55	1
Bolt with pin	02052-00	1
Fish line, l. 100m	02090-00	1
Support rod PHYWE, square, l 400mm	02026-55	2

Related Experiment

Torque

P1253500

Moments disk



Function and Applications

Disk to investigate general equilibrium conditions of a body submitted to forces and supported at its centre of gravity so that it can rotate.

Equipment and technical data

- Metallic disk, white on both sides with a central hole for low friction support on rod with pin.
- One side with auxiliary circles with angular scales.
- Disk diameter: 270 mm.
- Number of holes: 64; Grid constant (mm): 30 x 30.

02270-00

Torsional vibrations and torsion modulus

P2133000

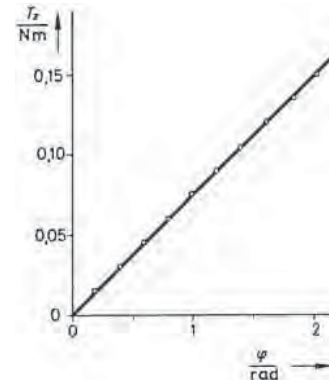

Torque and deflection of a torsion bar.

Principle

Bars of various materials will be exciting into torsional vibration. The relationship between the vibration period and the geometrical dimensions of the bars will be derived and the specific shear modulus for the material determined.

Tasks

1. Static determination of the torsion modulus of a bar.
2. Determination of the moment of inertia of the rod and weights fixed to the bar, from the vibration period.
3. Determination of the dependence of the vibration period on the length and thickness of the bars.
4. Determination of the shear modulus of steel, copper, aluminium and brass.

What you can learn about

- Shear modulus
- Angular velocity
- Torque
- Moment of inertia
- Angular restoring torque
- G-modulus
- Modulus of elasticity

Main articles

Torsion apparatus	02421-00	1
Spring Balance 1 N	03060-01	1
Spring balance 2,5 N	03060-02	1
Torsion rod, Al, l = 500 mm, d = 4 mm	02421-06	1
Torsion rod, Al, l = 500 mm, d = 3 mm	02421-05	1
Sliding weight	03929-00	2



P5160900 Shear waves in solid state materials

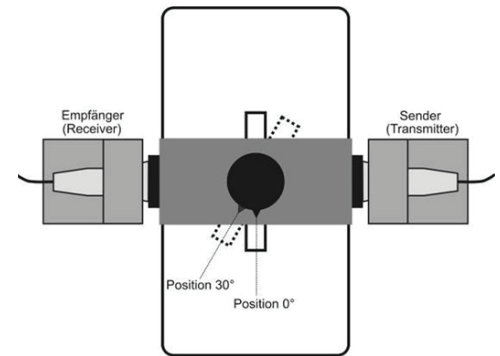
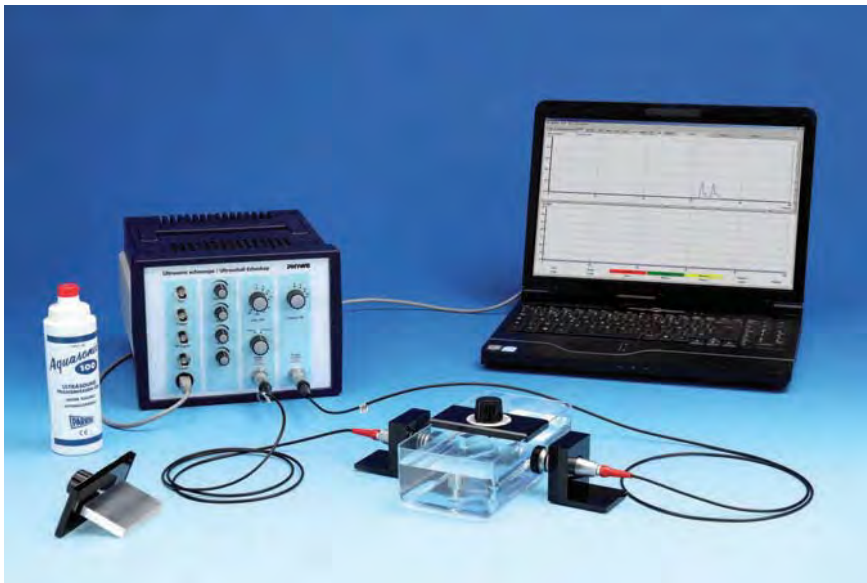

Schematic set-up with an indication of the angular positions.

Principle

The aim of this experiment is to study the generation and propagation of ultrasound waves in solid objects. In addition, the additional generation of transverse wave modes (shear wave modes) resulting from an oblique angle of incidence should be identified and the sound velocities for the longitudinal and transverse component should be determined. The relationship between the coefficients of elasticity of the material and its sound velocities enables the determination of the magnitude of the coefficients.

Tasks

1. Determine the sound amplitude of an ultrasound wave passing through an acrylic glass plate (transmission measurement) as a function of the angle of incidence for the longitudinal and transverse component.
2. Use the measurement curves to determine the longitudinal sound velocity in acrylic glass based on the angle of the total reflection, and the transverse sound velocity based on the amplitude maximums and the angle of the total reflection.
3. Determine the sound amplitude of an ultrasound wave passing through an aluminium plate (transmission measurement) as a function of the angle of incidence for the longitudinal and transverse component.
4. Use the measurement curves to determine the longitudinal sound velocity in aluminium, based on the angle of the total reflection, and the transverse sound velocity based on the angle of the amplitude maximums and the angle of the total reflection.
5. Based on the transverse and longitudinal sound velocities, calculate the coefficient of elasticity for acrylic glass and aluminium.

What you can learn about

- Ultrasonic transmission measurement; propagation of ultrasound waves; ultrasound wave modes; shear waves; longitudinal and transverse waves; modulus of elasticity; sound velocity

Main articles

Basic Set Ultrasonic echoscope	13921-99	1
Extension set: Shear waves	13921-03	1

Basic Set Ultrasonic echoscope



Function and Applications

With the ultrasonic echoscope the basics of ultrasound and its wave characteristics can be demonstrated. Terms like amplitude, frequency, sound velocity or Time Gain Control TGC will be explained. The cylinder set can be used to vividly demonstrate reflection as well as sound velocity and frequency depending on attenuation in solid state materials. The knowledge e.g. regarding sound velocity will be used to measure the test block. The principles of image formation from A-scan to B-scan can be explained. With the different probes the frequency depending resolution can be evaluated.

13921-99

Hooke's law (with Cobra4)

P2130160

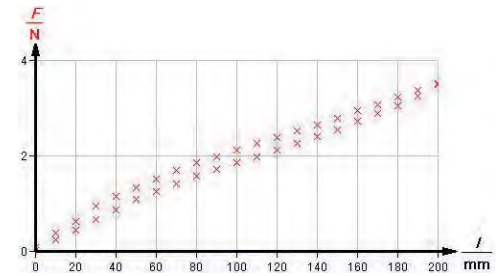
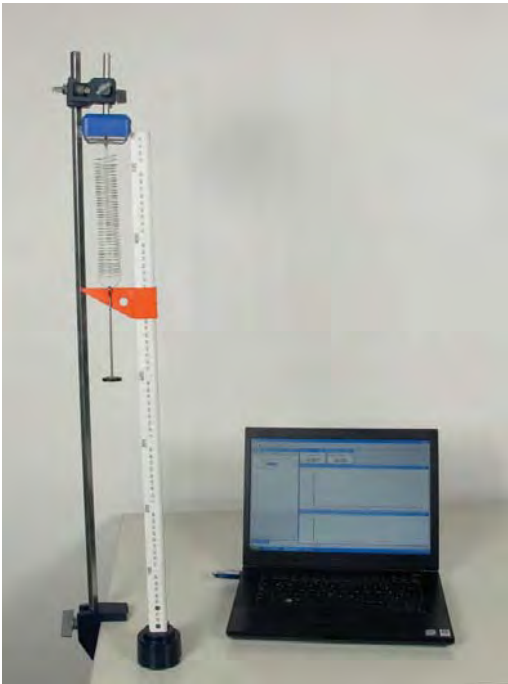

Measurement of the elongation of a rubber band.

Principle

The validity of Hooke's Law is proven using various helical springs with different spring constants. In comparison, the behaviour of a stretched rubber band is examined, for which there is no proportionality between acting force and resulting extension.

Tasks

1. Measurement of the tensile force as a function of the path for three different helical springs and a rubber band.
2. Determination of the spring constant and evaluation of a hysteresis curve.
3. Verification of Hooke's law.

What you can learn about

- Spring constant
- Limit of elasticity
- Extension and compression

Main articles

Cobra4 Wireless Manager	12600-00	1
Cobra4 Wireless-Link	12601-00	1
Cobra4 Sensor-Unit Force ± 4 N	12642-00	1
Software Cobra4 - multi-user licence	14550-61	1
Support base DEMO	02007-55	1
Scale, $l = 750$ mm, on rod	02200-00	1
Support rod PHYWE, square, $l = 1000$ mm	02028-55	1

Related Experiment

Hooke's law

P2130101

Cobra4 Sensor-Unit Force ± 4 N

Function and Applications

The Cobra4 Sensor-Unit Force ± 4 N contains a bending beam (DMS technology), which converts the mechanical load into an electrical signal.

12642-00

P2131500 Moment and angular momentum

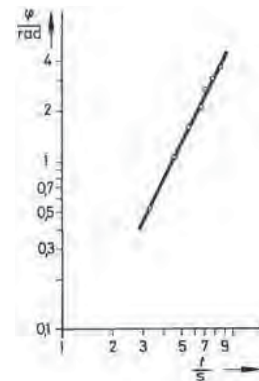
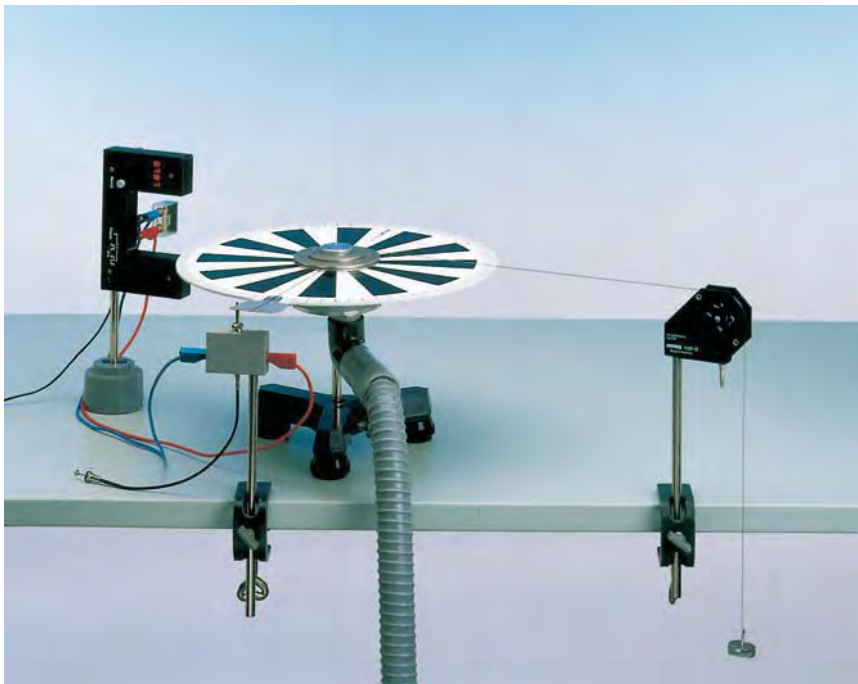

Angle of rotation as a function of time with uniformly accelerated rotary motion for $m = 0.01 \text{ kg}$, $r = 0.015 \text{ m}$.

Principle

The angle of rotation and angular velocity are measured as a function of time on a body which is pivoted so as to rotate without friction and which is acted on by a moment. The angular acceleration is determined as a function of the moment.

Tasks

With uniformly accelerated rotary motion, the following will be determined:

1. the angle of rotation as a function of time.
2. the angular velocity as a function of time.
3. the angular acceleration as a function of time.
4. the angular acceleration as a function of the lever arm.

What you can learn about

- Circular motion
- Angular velocity
- Angular acceleration
- Moment of inertia
- Newton's laws
- Rotation

Main articles

Blower 230V/50Hz	13770-97	1
Air bearing	02417-01	1
Light barrier with counter	11207-30	1
Holding device w. cable release	02417-04	1
Turntable with angle scale	02417-02	1
Precision pulley	11201-02	1
Tripod base PHYWE	02002-55	1

Turntable with angle scale



Function and Applications

Aluminium disk for rotator with air bearing (02417.88).

Equipment and technical data

- Painted white, with hole for axis bolt.
- Demonstrative 15° subdivision and fine scale with 1° subdivision.
- Moment of inertia: 126 kg cm^2 .
- Diameter: 350 mm .
- Fine/rough angle scale: $1^\circ/15^\circ$.

02417-02

Moment of inertia and angular acceleration with a precision pivot bearing

P2131305

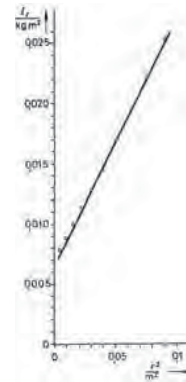
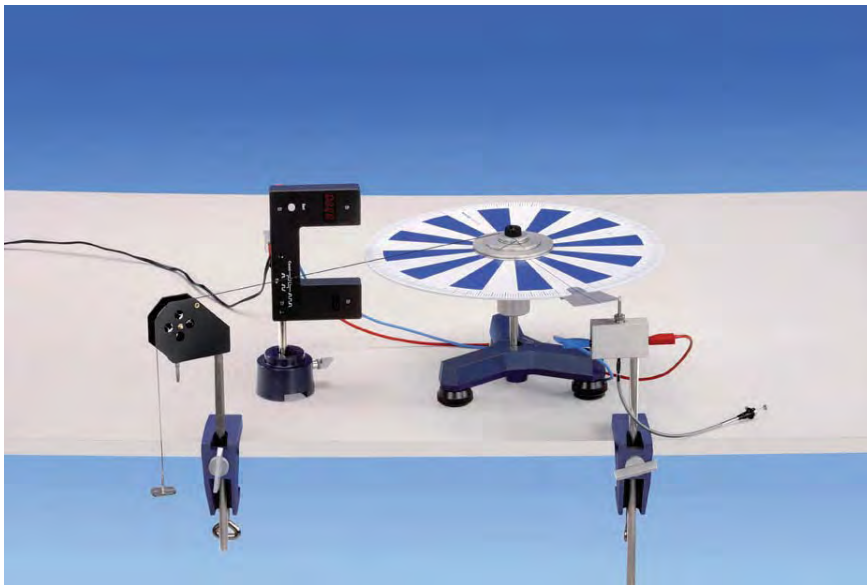

Moment of inertia of a mass point as a function of the square of its distance from the axis of rotation.

Principle

A moment acts on a body which can be rotated about a bearing without friction. The moment of inertia is determined from the angular acceleration.

Tasks

From the angular acceleration, the moment of inertia is determined as a function of the mass and the distance from the axis of rotation

1. of a disc
2. of a bar
3. of a mass point

What you can learn about

- Angular velocity
- Rotary motion
- Moment
- Moment of inertia of a disc
- Moment of inertia of a bar
- Moment of inertia of a mass point

Main articles

Precision pivot bearing	02419-00	1
Light barrier with counter	11207-30	1
Inertia rod	02417-03	1
Holding device w. cable release	02417-04	1
Turntable with angle scale	02417-02	2
Precision pulley	11201-02	1
Tripod base PHYWE	02002-55	1

Related Experiments

Moment of inertia and angular acceleration and with an air bearing

P2131301

Moment of inertia and angular acceleration and with an air bearing (with Cobra3)

P2131311

Moment of inertia and angular acceleration and a precision pivot bearing (with Cobra3)

P2131315

Cobra4 Experiment - available 2013

Moment of inertia and angular acceleration (with Cobra4)

P2131360

P2133100 Moments of inertia and torsional vibrations

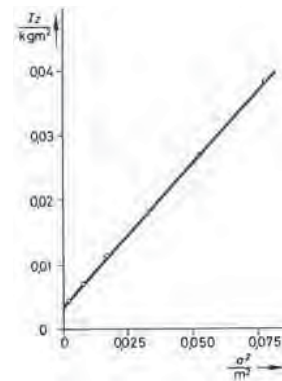

Moment of inertia of two equal masses, of 0.214 kg each, as a function of the distance between them.

Principle

Various bodies perform torsional vibrations about axes through their centres of gravity. The vibration period is measured and the moment of inertia determined from this.

Tasks

The following will be determined:

1. The angular restoring moment of the spiral spring.
2. The moment of inertia a) of a disc, two cylinder, a sphere and a bar, b) of two point masses, as a function of the perpendicular distance to the axis of rotation. The centre of gravity lies in the axis of rotation.

What you can learn about

- Rigid body
- Moment of inertia
- Axis of rotation
- Torsional vibration
- Spring constant
- Angular restoring moment
- Moment of inertia of a sphere, a disc, a cylinder, a long bar and of 2 point masses

Main articles

Light barrier with counter	11207-30	1
Rotation axle	02415-01	1
Sphere	02415-02	1
Rod with movable masses	02415-06	1
Hollow cylinder	02415-04	1
Disk	02415-03	1
Solid cylinder	02415-05	1

Related Experiment

Moment of inertia / Steiner's theorem

P2132801

Rotation axle



Function and Applications

A rotabel axle supports at two places in a frame which is held by a spiral spring to the frame. The axle, which projects at the top, carries a flange with tightening screw to take the various model objects. A tensions rod is applied to the frame, the axis of which coincides with the rotating axle of the instrument.

Equipment and technical data

- Height: 180 mm; Diameter stem: 10 mm.
- Spring constant: 2.5 Ncm/rad.

02415-01

Harmonic oscillations of spiral springs - Spring linked in parallel and series (with Cobra4)

P2132660

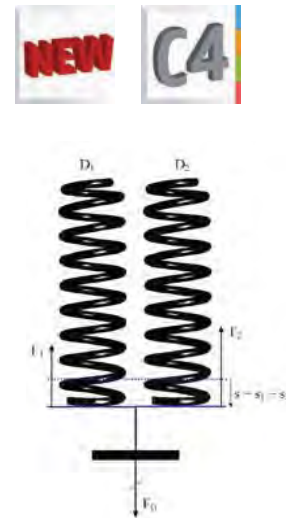

Parallel connection of helical springs.

Principle

The spring constant D is determined for different experimental set-ups from the oscillation period and the suspended mass.

Tasks

1. Determination of the spring constant D for different springs.
2. Determination of the spring constant for springs linked in parallel.
3. Determination of the spring constant for springs linked in series.

What you can learn about

- Spring constant
- Hooke's law oscillations
- Limit of elasticity
- Parallel springs
- Serial springs
- Use of an interface

Main articles

Cobra4 Wireless Manager	12600-00	1
Cobra4 Wireless-Link	12601-00	1
Cobra4 Sensor-Unit Force ± 4 N	12642-00	1
Software Cobra4 - multi-user licence	14550-61	1
Tripod base PHYWE	02002-55	1
Support rod PHYWE, square, $l = 1000$ mm	02028-55	1
Right angle clamp PHYWE	02040-55	1

Cobra4 Sensor-Unit Force ± 4 N

Function and Applications

The Cobra4 Sensor-Unit Force ± 4 N contains a bending beam (DMS technology), which converts the mechanical load into an electrical signal.

Benefits

- Depending on the type of application, the force sensor can be connected to the Cobra4 Wireless-Link, the Cobra4 Mobile-Link, the Cobra4 Junior-Link or the Cobra4 USB-Link using a secure and reliable plug-in / lockable connection.
- On the top of the casing, a plate can be plugged in for measuring weights that are placed on it.
- On the bottom of the device, there is a hook on which weights may be hung.
- On the mechanically secure in take of the Cobra4 sensor unit, force from above or below is applied using a drop rod with a M6 thread.

Equipment and technical data

- 100 mm long rod with M6 thread
- Weight plate, weight hook
- Operating manual
- Measuring range: $-4 \dots +4$ N
- Maximum sampling rate: 16 Hz
- Measuring accuracy: 0.2 mN
- Dimensions (L x B x H): 64 x 70 x 35 mm
- Weight: 100 g

12642-00

P2132701 Forced oscillations - Pohl's pendulum

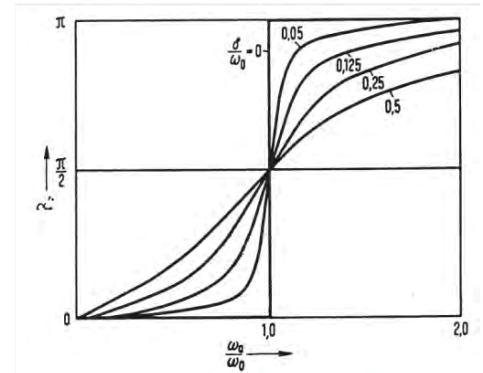
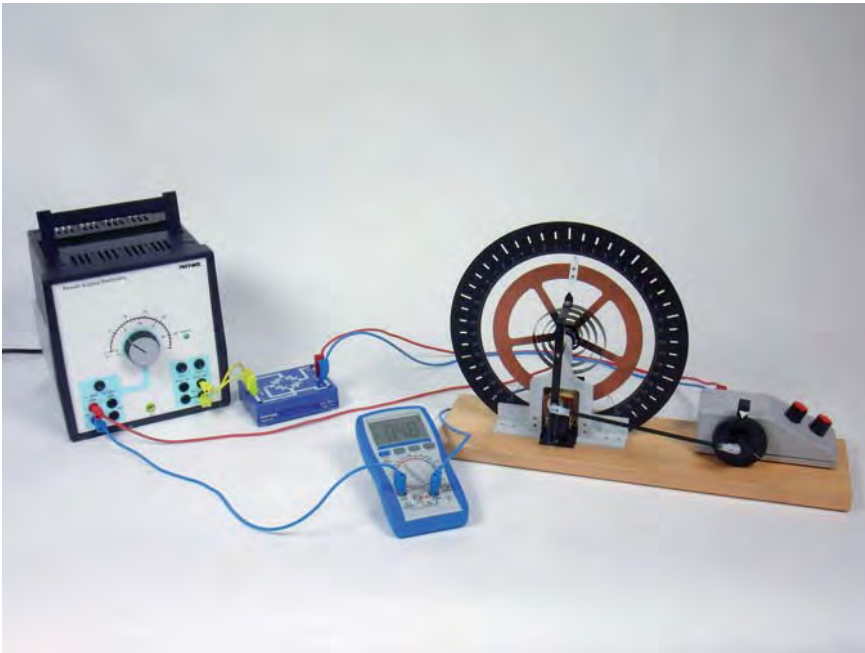

Resonance curves for different dampings.

Principle

If an oscillating system is allowed to swing freely it is observed that the decrease of successive maximum amplitudes is highly dependent on the damping. If the oscillating system is stimulated to swing by an external periodic torque, we observe that in the steady state the amplitude is a function of the frequency and the amplitude of the external periodic torque and of the damping. The characteristic frequencies of the free oscillation as well as the resonance curves of the forced oscillation for different damping values are to be determined

Tasks

A. Free oscillation

1. To determine the oscillating period and the characteristic frequency of the undamped case.
2. To determine the oscillating periods and the corresponding characteristic frequencies for different damping values. Successive, unidirectional maximum amplitudes are to be plotted as a function of time. The corresponding ratios of attenuation, the damping constants and the logarithmic decrements are to be calculated.
3. To realise the aperiodic case and the creeping.

B. Forced oscillation

1. The resonance curves are to be determined and to be represented graphically using the damping values of A .
2. The resonance frequencies are to be determined and are to be compared with the resonance frequency values found before hand.
3. The phase shifting between the torsion pendulum and the stimulating external torque is to be observed for a small damping value assuming that in one case the stimulating

frequency is far below the resonance frequency and in the other case it is far above it.

What you can learn about

- Angular frequency; Characteristic frequency; Resonance frequency
- Torsion pendulum; Torsional vibration; Torque and restoring torque
- Damped/ undamped free oscillation; Forced oscillation
- Ratio of attenuation/ decrement; Damping constant
- Logarithmic decrement; Aperiodic case; Creeping

Main articles

Torsion pendulum after Pohl	11214-00	1
Variable transformer, 25 VAC/ 20 VDC, 12 A	13531-93	1
Bridge rectifier, 30V AC/1A DC	06031-10	1
Digital multimeter 2010	07128-00	1
Stopwatch, digital, 1/100 s	03071-01	1

Cobra4 Experiment - available 2013

Forced oscillations - Pohl's pendulum (with Cobra4)

P2132760

Laws of gyroscopes / 3-axis gyroscope

P2131900

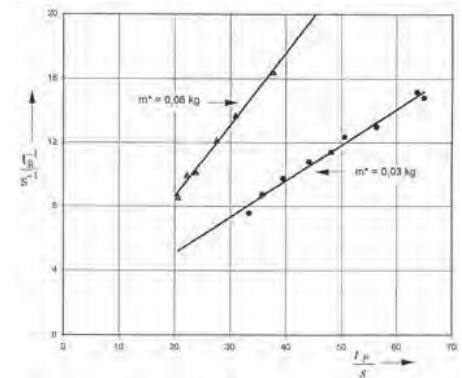

Determination of the momentum of inertia from the slope of straight line $(tR)^{-1} = f(tP)$.

Principle

The momentum of inertia of the gyroscope is investigated by measuring the angular acceleration caused by torques of different known values. In this experiment, two of the axes of the gyroscope are fixed. The relationship between the precession frequency and the gyro-frequency of the gyroscope with 3 free axes is examined for torques of different values applied to the axis of rotation. If the axis of rotation of the force free gyroscope is slightly displaced, a nutation is induced. The nutation frequency will be investigated as a function of gyro frequency.

Tasks

1. Determination of the momentum of inertia of the gyroscope by measurement of the angular acceleration.
2. Determination of the momentum of inertia by measurement of the gyro-frequency and precession frequency.
3. Investigation of the relationship between precession and gyro-frequency and its dependence from torque.
4. Investigation of the relationship between nutation frequency and gyro-frequency.

What you can learn about

- Momentum of inertia; Angular momentum
- Torque
- Precession; Nutation

Main articles

Gyroscope with 3 axes	02555-00	1
Light barrier with counter	11207-30	1
Additional gyro-disk w. c-weight	02556-00	1
Power supply 5 V DC/2.4 A with 4 mm plugs	11076-99	1

Gyroscope with 3 axes**Function and Applications**

Demonstration and practical set for working up the gyroscope laws.

Benefits

The following relationships can be produced:

- Precession (influence of torque and rotational frequency)
- Nutation (influence of the speed of the disc on the nutational frequency)
- Measurement of the moment of inertia of the gyroscope disc from the angular acceleration for a known torque
- Investigation of the relationship between the duration of a precession rotation and the rotational frequency of the gyroscope disc; Investigation of the relationship between the precession frequency and the turning moment exerted on the gyroscope axis for constant rotational frequency of the disc
- Determination of the relationship between the rotational and nutational frequency of the gyroscope disc
- Gyroscope disc with double ball bearings, balanced and freely movable via 3 axes, which is wound up by hand with the aid of a thread
- Mounted on a metal stand; Sliding counterweight for calibrating the gyro disc

Equipment and technical data

- Disc diameter: 245 mm, Disc thickness: 25 mm
- Disc weight: approx. 1317 g, Counterweight: approx. 925 g

02555-00

P2132000 **Laws of gyroscopes / cardanic gyroscope**

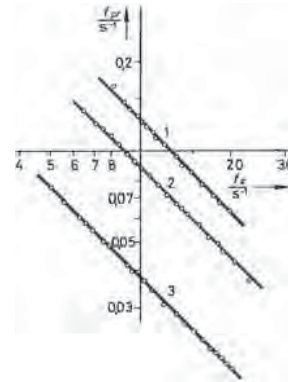

Precession frequency as a function of the gyro frequency for different additional masses.

Principle

If the axis of rotation of the force-free gyroscope is displaced slightly, a nutation is produced. The relationship between precession frequency or nutation frequency and gyro-frequency is examined for different moments of inertia. Additional weights are applied to a gyroscope mounted on gimbals, so causing a precession.

Tasks

1. To determine the precession frequency as a function of the torque and the angular velocity of the gyroscope.
2. To determine the nutational frequency as a function of the angular velocity and the moment of inertia.

What you can learn about

- Moment of inertia
- Torque
- Angular momentum
- Nutation
- Precession

Main articles

Gyroscope, Magnus type, incl. handbook	02550-00	1
Digital stroboscope	21809-93	1
Stopwatch, digital, 1/100 s	03071-01	1

Gyroscope, Magnus type, incl. handbook



Function and Applications

Gyroscope, Magnus type, universal gyroscope for demonstration and quantitative evaluation of gyroscope laws and their application.

Benefits

Rich accessories to demonstrate the following topics:

- Symmetrical and asymmetrical elongated and flattened gyroscope
- Force free, driven and captive gyroscope; navigational gyro compass

Equipment and technical data

- Steel gyroscope disc with reinforced edge suspended in gimbals with bolt bearings; Springs and clamps for restriction
- Variation of moments of inertia by supplementary steel-weights; Disk diameter: 128 mm; Storage box (mm): 355 x 380 x 385; Including manual of 124 pages

02550-00

Software "Measure Dynamics", campus licence



Function and Application

Software "measure Dynamics", automatic video analysis of movements. The new measurement software "measure Dynamics" provides an inexpensive way to analyze movements and display them in the shape of diagrams. All you need is a digital video camera, whereby modern webcams, camcorders or common digital cameras with film mode function are completely sufficient. The campus licence permits the installation of the software on every computer at the campus and on all personal PCs of the students and teachers belonging to the campus!

Benefits

- Automatic object recognition and tracing, including several filmed objects simultaneously, e.g. coupled pendulum.
- Dialogue-supported creation of trajectories as well as movement, velocity and acceleration diagrams.
- Stroboscopic effect for motion sequences (visualization of the entire path of movement).
- Easy data transfer of all measured values to MS Excel®, PHYWE measure, and other applications.
- Video processing inclusive of cutting, compression, etc.
- Software-guided modeling for didactical transfers (including homework).

Possible Applications

- Demonstration experiments in the lecture hall, for example, all types of one-dimensional and two-dimensional movements.
- "Field studies", for example, display of motion sequences in shot-putting, basket-shooting in basketball, trampoline jumping, high-jump, and much more.

14440-62

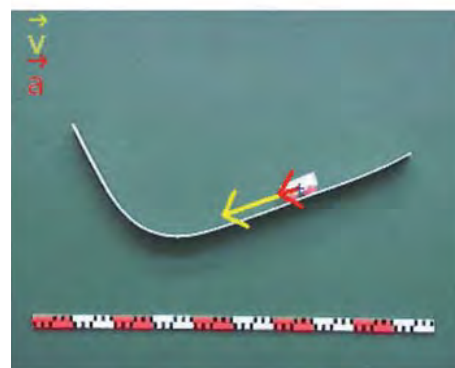
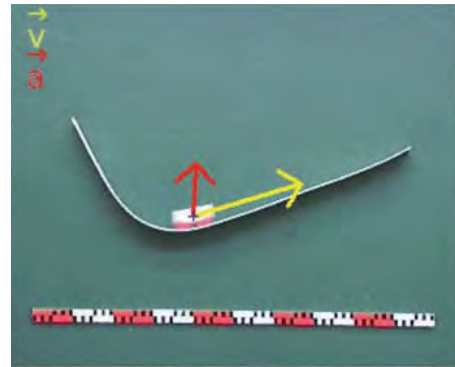

Speed and acceleration of a car in a roller coaster.

EduMedia Award for Didactical Software

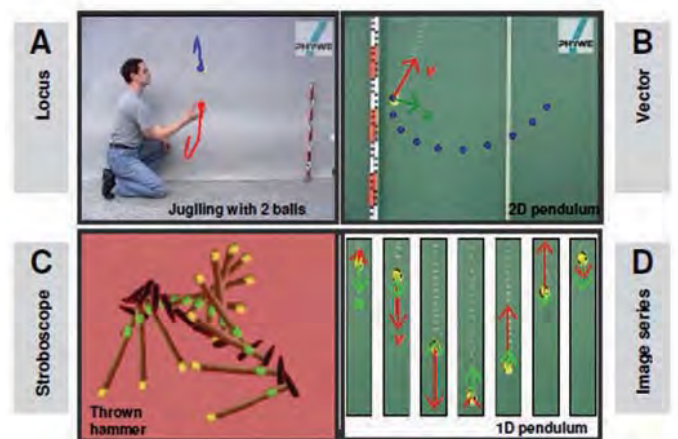

Possibilities in measure Dynamics for supporting the phenomenological recording of movements.

P2140100 Density of liquids

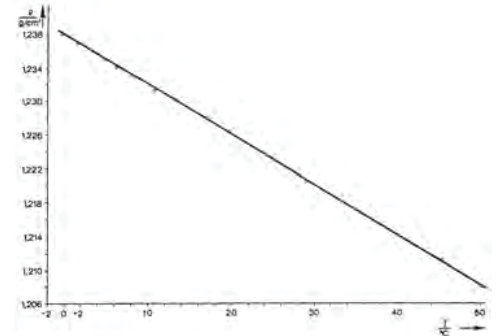

Density of water as a function of temperature.

Principle

The density of water and glycerol is determined as a function of temperature using the Mohr balance.

Task

The density of water and glycerol is measured in 1 to 2 °C steps over a temperature range from 0 to 20 °C, then in larger steps up to 50 °C.

What you can learn about

- Hydrogen bond
- Water anomaly
- Volume expansion
- Melting
- Evaporation
- Mohr balance

Main articles

Westphal/ Mohr density balance	45016-00	1
Immersion thermostat Alpha A, 230 V	08493-93	1
Bath for thermostat, makrolon	08487-02	1
External circulation set f. thermostat Alpha A	08493-02	1
Cooling coil for thermostat Alpha A	08493-01	1
Glycerol 250 ml	30084-25	2
Sodium chloride, 500 g	30155-50	1

Westphal / Mohr density balance



Function and Applications

Precision balance with balance bar with unequal arm length for determination of densities of liquids and solid state bodies.

Equipment and technical data

- The bearing of the balance bar consists of a low friction steel cutting edge, with height variable support rod
- Balance bar equipped with 9 positions for counter weight pieces
- Delivered in wooden storage box, counter weight pieces
- Tweezers, Reimann's buoyancy body with wire, thermometer
- Glass cylinder, 100 ml, grid basket with hook for density determination of solid state bodies, beaker
- Weight range: 0...2 g/ccm; Sensitivity: 0.0001 g/ccm

45016-00

Surface of rotating liquids

P2140200

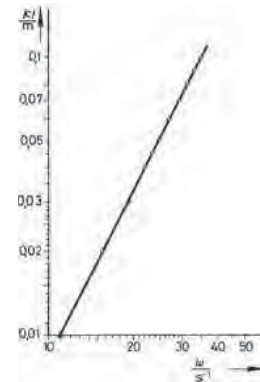
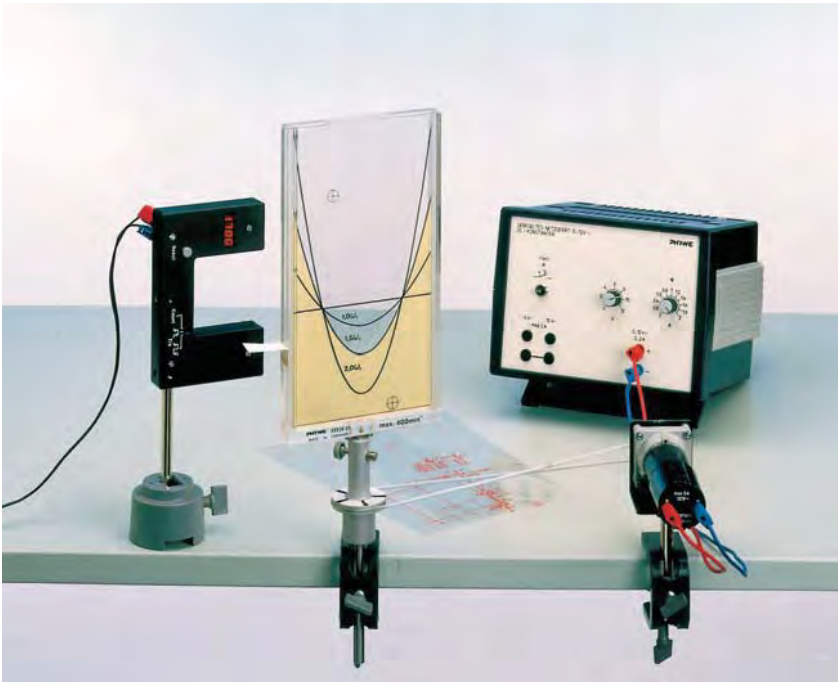

Location of the lowest point c of the liquid as a function of the angular velocity.

Principle

A vessel containing liquid is rotated about an axis. The liquid surface forms a paraboloid of rotation, the parameters of which will be determined as a function of the angular velocity.

Tasks

On the rotating liquid surface, the following will be determined:

1. the shape,
2. the location of the lowest point as a function of the angular velocity,
3. the curvature.

What you can learn about

- Angular velocity
- Centrifugal force
- Rotary motion
- Paraboloid of rotation
- Equilibrium

Main articles

Light barrier with counter	11207-30	1
Power supply 0...12 V DC/ 6 V, 12 V AC, 230 V	13505-93	1
Rotating liquid cell	02536-01	1
Motor, with gearing, 12 VDC	11610-00	1
Bearing unit	02845-00	1
Power supply 5 V DC/2.4 A with 4 mm plugs	11076-99	1
Bench clamp PHYWE	02010-00	2

Rotating liquid cell

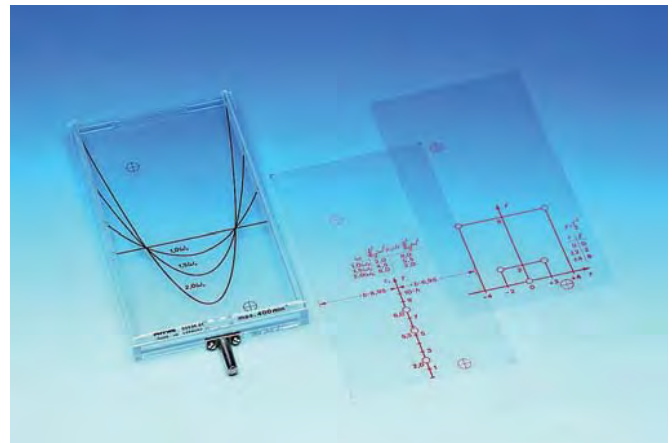

Function and Applications

Rotatable cell on stem for investigation of surface shapes of liquids.

Equipment and technical data

- Flat Plexiglas cuvette with attachable transparent window with 3 different parabolas.
- 2 transparent slides with coordinates for quantitative investigation.
- Material: Plexiglas.
- Dimensions (mm): 138 x 5 x 265.
- Diameter stem: 10 mm.

02536-01

P2140300 Viscosity of Newtonian and non-Newtonian liquids (rotary viscometer)

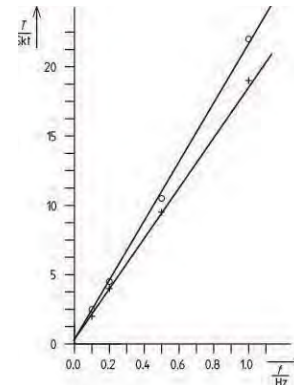

Moment of rotation as a function of the frequency for a Newtonian liquid glycerol (+), liquid paraffin (o).

Principle

The viscosity of liquids can be determined with a rotation viscometer, in which a motor with variable rotation speed drives a cylinder immersed in the liquid to be investigated with a spiral spring. The viscosity of the liquid generates a moment of rotation at the cylinder which can be measured with the aid of the torsion of the spiral spring and read on a scale.

Tasks

1. Determine the gradient of the rotational velocity as a function of the torsional shearing stress for two Newtonian liquids (glycerine, liquid paraffin).
2. Investigate the temperature dependence of the viscosity of castor oil and glycerine.
3. Determine the flow curve for a non-Newtonian liquid (chocolate).

What you can learn about

- Shear stress
- Velocity gradient
- Internal friction
- Viscosity
- Plasticity

Main articles

Rotary viscometer, 15 - 2,000,000 mPas, 110...240 V	18223-99	1
Magnetic stirrer MR Hei-Standard	35750-93	1
Electronic temperature controller EKT Hei-Con	35750-01	1
Glycerol 250 ml	30084-25	2
Castor oil 250 ml	31799-27	2

Rotary viscometer, 15 - 2,000,000 mPas, 110...240 V

Function and Applications

Classic rotational viscometer for the viscosity determination according to ISO2555 ("Brookfield method") and many ASTM standards.

Benefits

- The results are 100% compatible to the Brookfield method
- All results (viscosity, torque in %, speed, spindle) are displayed on the built-in display, multilanguage display: English, French, German, Spanish, Italian, Japanese, Portuguese, Dutch, Polish, Catalan
- Visual and acoustic signals at critical measuring conditions, Warning, if the device is used outside of the permissible measuring ranges, Digital speed control with "built-in" accuracy through stepping motor
- Touchless, optoelectronic torque measuring system with high accuracy and without wear

Equipment and technical data

- Viscosity range: 15 - 2,000,000 m Pas in 84 ranges (21 speeds and 4 spindles); Torque (rpm): 0.1/ 0.2/ 0.3/ 0.5/ 0.6/ 1/ 1.5/ 2/ 2.5/ 3/ 4/ 5/ 6/ 10/ 12/ 20/ 30/ 50/ 60/ 100/ 200

18223-99

Viscosity measurement with the falling ball viscometer

P2140400

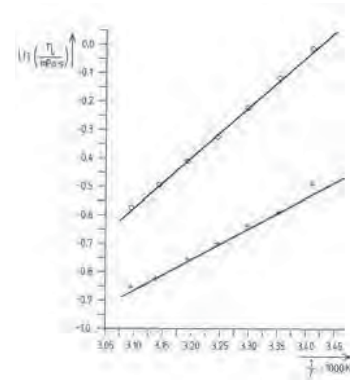
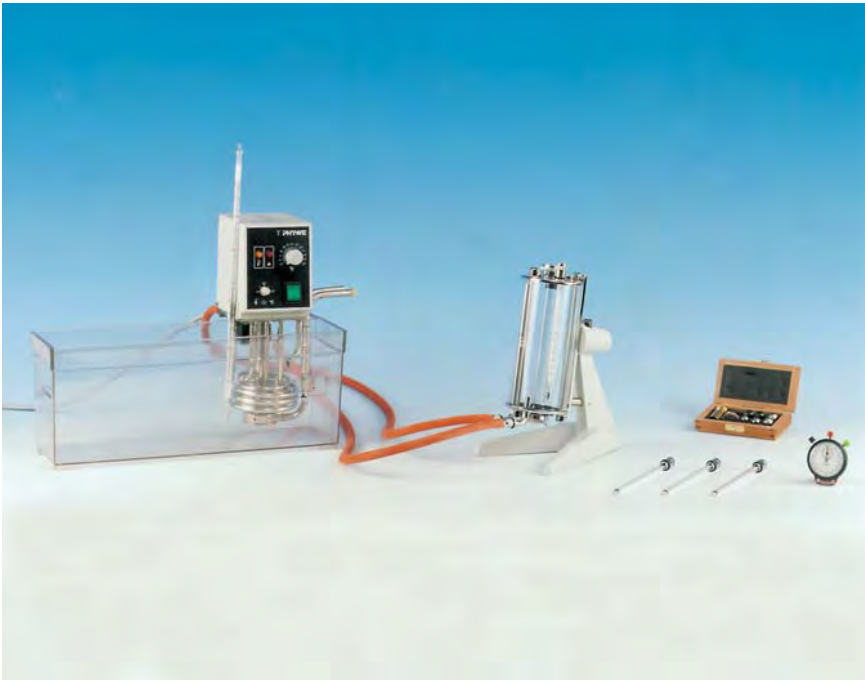

Temperature dependence of the dynamic viscosity of water (o) and methanol (+), respectively.

Principle

Due to internal friction among their particles, liquids and gases have different viscosities. The viscosity, a function of the substance's structure and its temperature, can be experimentally determined, for example, by measuring the rate of fall of a ball in a tube filled with the liquid to be investigated.

Tasks

Measure the viscosity

1. of methanol-water mixtures of various composition at a constant temperature,
2. of water as a function of temperature and
3. of methanol as a function of temperature.

From the temperature dependence of the viscosity, calculate the energy barriers for the displace ability of water and methanol.

What you can learn about

- Liquid; Newtonian liquid
- Stokes law; Fluidity
- Dynamic and kinematic viscosity
- Viscosity measurements

Main articles

Falling ball viscometer	18220-00	1
Immersion thermostat Alpha A, 230 V	08493-93	1
Thermometer, 24...+ 51 °C, for 18220-00	18220-02	1
Bath for thermostat, makrolon	08487-02	1
External circulation set f. thermostat Alpha A	08493-02	1
Set of Precision Balance Sartorius CPA 623S and measure software, 230 V	49224-88	1

Falling ball viscometer



Function and Applications

Falling ball viscometer.

Equipment and technical data

- Thermometer
- Diameter of the fall tube: 15.95 mm
- Initiabile fall times: 25...300 s
- Fall distance: 100 mm
- 6 balls

18220-00

P2140500 Surface tension with the ring method (Du Nouy method)

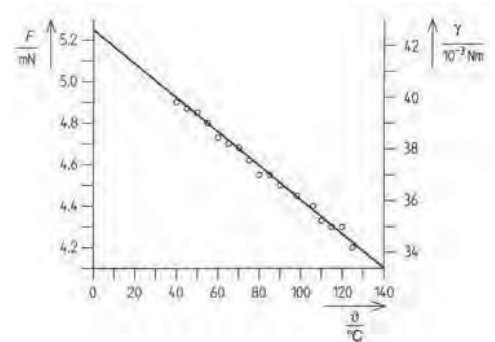

Temperature dependency of surface tension of olive oil.

Principle

The force is measured on a ring shortly before a liquid film tears using a torsion meter. The surface tension is calculated from the diameter of the ring and the tear-off force.

Tasks

1. Determine the surface tension of olive oil as a function of temperature.
2. Determine the surface tension of water/methanol mixtures as functions of the mixture ratio.

What you can learn about

- Surface energy
- Interface
- Surface tension
- Adhesion
- Critical point
- Eötvös equation

Main articles

Torsion dynamometer, 0.01 N	02416-00	1
Magnetic stirrer MR Hei-Standard	35750-93	1
Electronic temperature controller EKT Hei-Con	35750-01	1
Retort stand, 210 mm × 130 mm, h = 500 mm	37692-00	1
Ethyl alcohol, absolute 500 ml	30008-50	1
Surface tension measuring ring	17547-00	1
Water jet pump, plastic	02728-00	1

Torsion dynamometer, 0.01 N



Function and Applications

Torsion dynamometer to measure small forces or investigate electrostatic and magnetic interactions between bodies.

Benefits

- Force compensation; Zero point adjustment
- Eddy current damping element, Front and side scales
- Overload protection and a stem

Equipment and technical data

- Range front scale: 10 mN; Range side scale: ± 3 mN
- Raw subdivision: 1 mN; Fine subdivision: 0.1 mN
- Maximum lever load: 0.2 N
- Scale diameter: 170 mm; Length of lever arm: 240 mm

02416-00

Barometric height formula

P2140700

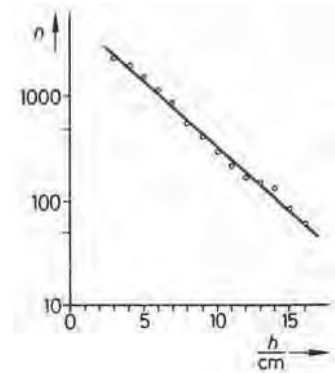

Number of steel balls ($m = 0.034$ g), as a function of the height h , which pass through the volume element V in 30 seconds (vibrational frequency 50 Hz).

Principle

Glass or steel balls are accelerated by means of a vibrating plate, and thereby attain different velocities (temperature model). The particle density of the balls is measured as a function of the height and the vibrational frequency of the plate.

Tasks

Measurement of the particle density as a function of:

1. the height, at fixed frequency.
2. the vibrational frequency of the exciting plate, at fixed height.

What you can learn about

- Kinetic gas theory
- Pressure
- Equation of state
- Temperature
- Gas constant

Main articles

Kinetic gas theory apparatus	09060-00	1
Digital stroboscope	21809-93	1
Power supply variable 15 VAC/ 12 VDC/ 5 A	13530-93	1
Light barrier with counter	11207-30	1
Tripod base PHYWE	02002-55	2
Power supply 5 V DC/2.4 A with 4 mm plugs	11076-99	1
Stopwatch, digital, 1/100 s	03071-01	1

Kinetic gas theory apparatus



Function and Applications

Kinetic gas theory apparatus with vertical chamber and built in motor.

Equipment and technical data

- Chamber (mm) 60 x 20 x 180
- Motor supply 12 VDC /20 W

09060-00

P2260511 LDA - laser Doppler anemometry with optical base plate (with Cobra3)

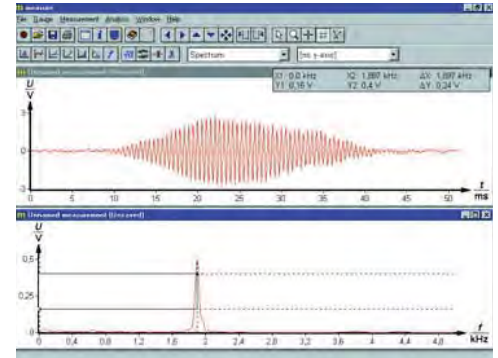

Measurement of the signal spectrum with a signal peak.

Principle

Small particles in a current pass through the LDA measuring volume and scatter the light whose frequency is shifted by the Doppler effect due to the particle movement.

The frequency change of the scattered light is detected and converted into a particle or flow velocity.

Task

Measurement of the light-frequency change of individual light beams which are reflected by moving particles.

What you can learn about

- Interference
- Doppler effect
- Scattering of light by small particles (Mie scattering)
- High- and low-pass filters
- Sampling theorem
- Spectral power density
- Turbulence

Main articles

He/Ne Laser, 5mW with holder	08701-00	1
Power supply for laser head 5 mW	08702-93	1
Cobra3 BASIC-UNIT, USB	12150-50	1
Si-Photodetector with Amplifier	08735-00	1
Optical base plate with rubberfeet	08700-00	1
Sliding device, horizontal	08713-00	1
LDA-Accessory-Set	08740-00	1

Cobra4 Experiment - available 2013

LDA - Laser Doppler Anemometry (with Cobra4)

P2260560

Control Unit for Si-Photodetector

Function and Applications

Amplifier for silicon photodetector.

Equipment and technical data

- 3 BNC outputs:
 - Output 1 (monitor output), gain 1, bandwidth for DC ... 60 kHz
 - Output 2, gain 1 ... 100, band width for AC 10 Hz ... 60 kHz
 - Output 3 (filter output), gain 1 ... 100, band width for AC 200 Hz ... 10 kHz
- Input: 5-pole diode socket for silicon photodetector
- Connections +9 V ... +12 V; Power consumption 1 W
- Impact-resistant plastic case (194 x 140 x 130) mm with carrying handle, includes 110-V/240-V power supply

08735-99

Mechanics of flow

P5140100

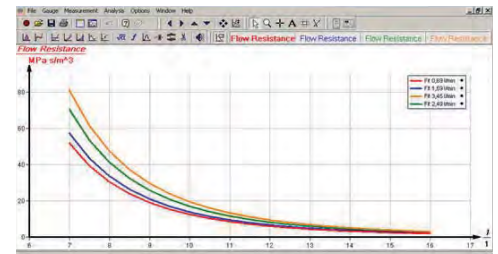
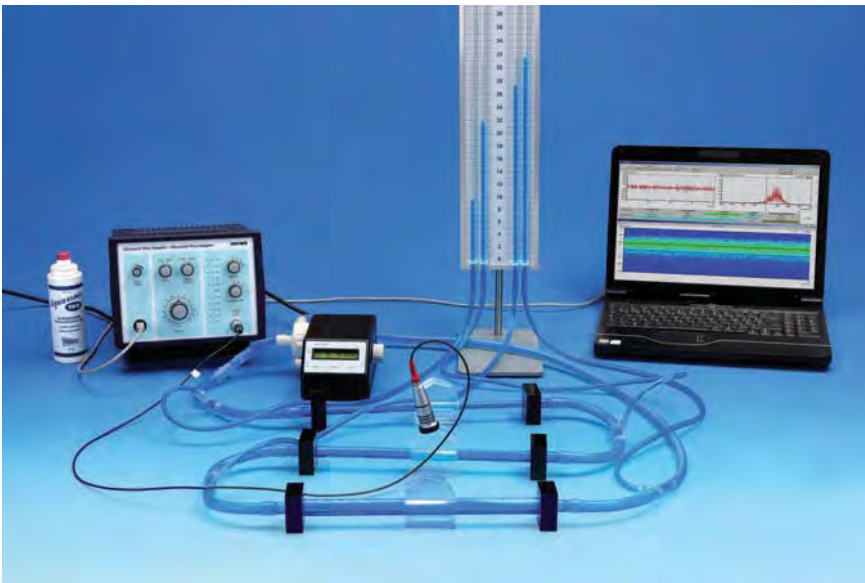

The dependence of the resistance on the tube diameter.

Principle

The Doppler effect is used with ultrasonic waves to investigate the laws of stationary laminar flow, which underlie a many great technical applications. The liquid under investigation flows through a circuit of tubing. Particular aspects to be studied experimentally include the relationship between the speed of flow and the surface of the tubing (continuity condition) plus that between the resistance to the flow and the diameter of the tube (Hagen-Poiseuille law). By means of these two laws, the dynamic viscosity or fluidity can be derived using familiar geometry.

Tasks

1. Measure the average speed of 3 different flows using the ultrasonic Doppler sonograph with Doppler prisms. Determine the nature of the flow.
2. Measure the drop in pressure between the measuring points and determine the resistance to the flow.
3. Calculate viscosity and fluidity and compare with those for other liquids.

What you can learn about

- Ultrasonic Doppler effect
- Laminar and turbulent flow
- Continuity equation
- Bernoulli's equation
- Hagen-Poiseuille law
- Viscosity and fluidity

Main articles

Basic set: Ultrasonic Doppler technique	13923-99	1
Extension Set: Mechanics of flow	13923-01	1

Related Experiment

Flow Measurement Ultrasonic Doppler effect

P5142100

Basic set: Ultrasonic Doppler technique



Function and Applications

Kit containing instrument and accessories for general ultrasonic sonography experiments. The software displays the measured data from the ultrasonic Doppler apparatus, basic instrument of this kit, in realtime on the computer screen. Modular and extendable with accessory kits for experimentations in the fields of hydraulics and medical diagnostics.

13923-99

P5141100 Level measurement

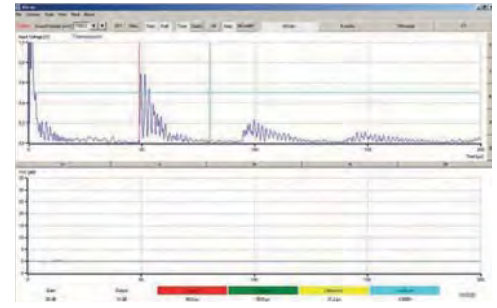

Set-up of the ultrasonic probe for monitoring limit values and for continuous measurements.

Principle

For the experiment, a level measuring system for a two-phase liquid tank is set up and a calibration curve for the filling volumes is recorded. One task is to determine the minimum measurement volume ("dead band"). For maximum tank filling, an ultrasonic limit switch is to be tested. Level measurements play an important role for many industrial processes. Particularly for the automation of these processes, level meters are used to determine the content volume of tank systems, silos, reactors, collecting reservoirs, etc.

Tasks

1. Set up a level measurement system for continuous measurements.
2. Determine the minimum detectable filling level ("dead band") and the associated liquid volume.
3. Perform a volume calibration for two different liquids (water and oil) for the tank.
4. Record and analyse suitable ultrasound signals for a limit switch.
5. Perform a level measurement with a two-phase system (water-oil).

What you can learn about

- Limit value monitoring; Continuous measurement
- Initial echo; Multiple reflections
- Time of flight; Sound velocity; Acoustic impedance

Main articles

Basic Set Ultrasonic echoscope	13921-99	1
Support base variable	02001-00	1
Universal clamp	37718-00	2
Boss head	02043-00	2
Graduated cylinder 250 ml	36630-00	1

Basic Set Ultrasonic echoscope



Function and Applications

With the ultrasonic echoscope the basics of ultrasound and its wave characteristics can be demonstrated. Terms like amplitude, frequency, sound velocity or Time Gain Control TGC will be explained.

The cylinder set can be used to vividly demonstrate reflection as well as sound velocity and frequency depending on attenuation in solid state materials.

The knowledge e.g. regarding sound velocity will be used to measure the test block. The principles of image formation from A-scan to B-scan can be explained. With the different probes the frequency depending resolution can be evaluated.

13921-99

Optical determination of the velocity of sound in liquids

P2151000

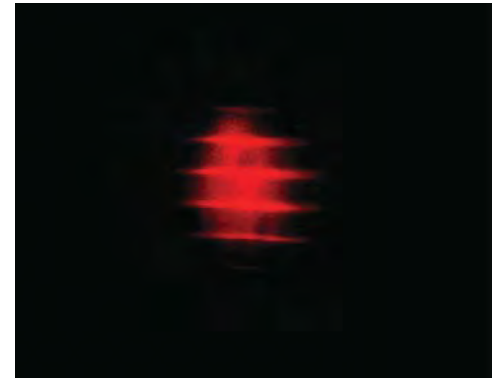
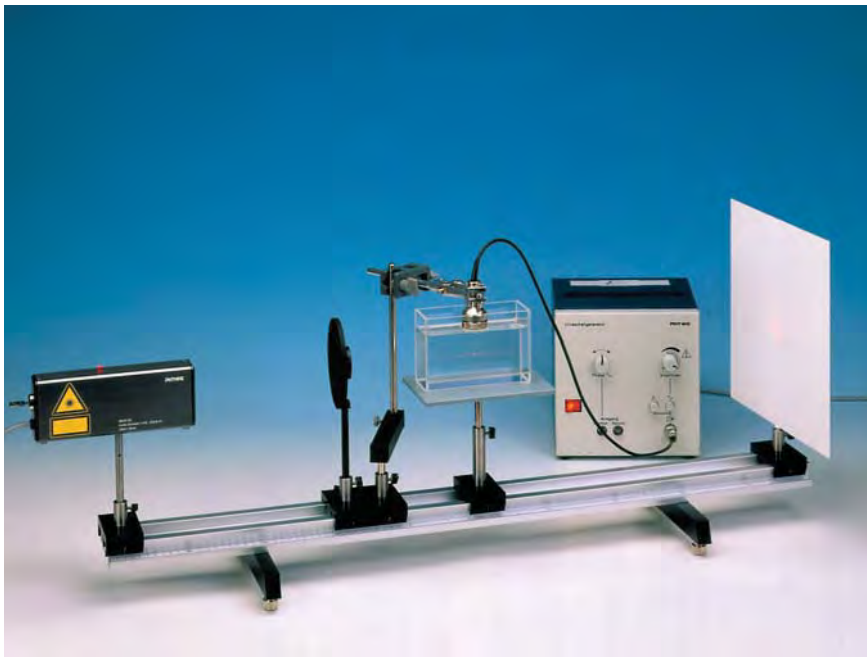

Resulting diffraction pattern on the screen.

Principle

A stationary ultrasonic wave in a glass cell full of liquid is traversed by a divergent beam of light. The sound wave length can be determined from the central projection of the sound field on the basis of the refractive index which changes with the sound pressure.

Tasks

To determine the wavelength of sound in liquids, and from this calculate the sound velocity, from the structure of the centrally projected image.

What you can learn about

- Ultrasonics
- Sound velocity
- Frequency
- Wavelength
- Sound pressure
- Stationary waves

Main articles

Ultrasonic generator	13920-99	1
Laser, He-Ne, 1.0 mW, 230 V AC	08181-93	1
Glass cell, 150x55x100 mm	03504-00	1
Optical profile-bench, l 1000mm	08282-00	1
Screen, metal, 300 x 300 mm	08062-00	1
Swinging arm	08256-00	1
Slide mount for optical bench, h = 80 mm	08286-02	1

Ultrasonic generator



Function and Applications

Ultrasonic generator for sine- and pulse operation for experimentation with wave phenomena and run time measurements, for exemplary technical applications e.g. ultrasonic welding.

Equipment and technical data

- With 3-digit LED for frequency and adjustable frequency for optimisation experiments and exactly determination of wave length under different experimental conditions.
- Monitor- and trigger-outputs with BNC sockets for phase determination with an oscilloscope.
- Robust plastic housing; Including sealed sound head
- Frequency range (sinus): 780...820 kHz
- Maximum sound output power: 16 W
- Puls repetition frequency: 500 Hz
- Puls duration: 3 μ s; Supply voltage: 110...240 V AC
- Dimensions, H x W x D (mm): 170 x 232 x 260; Mass: 3.67 kg

13920-99

P2151100 Phase and group velocity of ultrasound in liquids

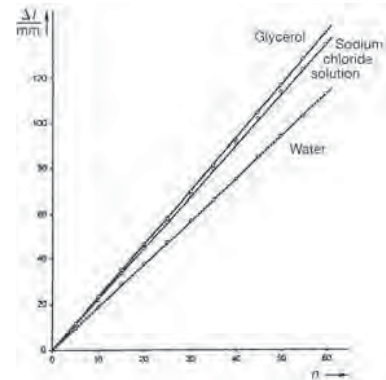
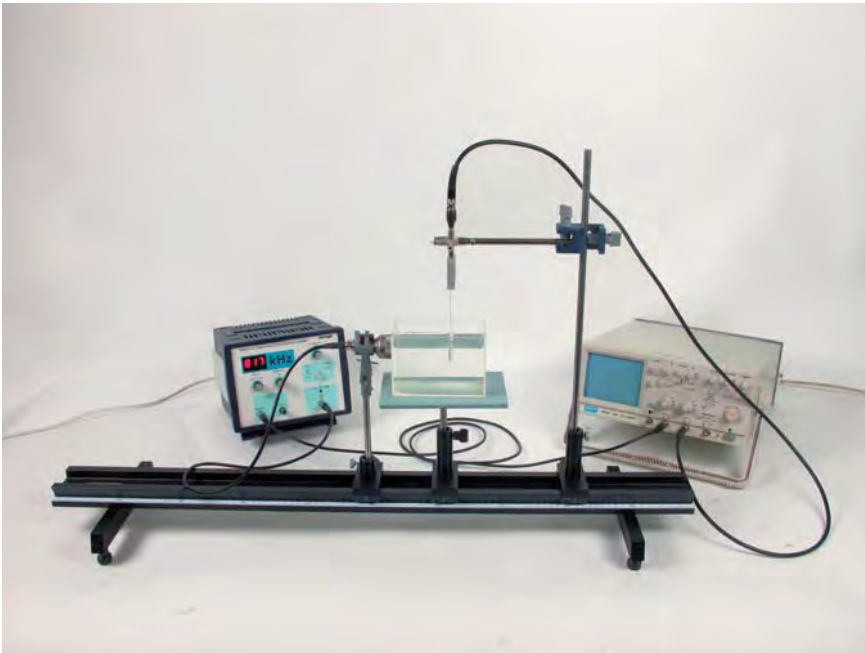

Detector displacement / as a function of the number n of wavelengths covered, for water, glycerol and sodium chloride solution (temperature = 25 °C).

Principle

The sound waves transmitted to a liquid by the ultrasonic generator are picked up by a piezoelectric ultrasonic pick-up and the signal from transmitter and receiver compared on an oscilloscope.

The wavelength is determined and the phase velocity calculated from the relative phase position of the signals.

The group velocity is determined from measurements of the sound pulse delay time.

Tasks

The signals from the ultrasonic generator and the ultrasonic pick-up are recorded on the oscilloscope.

1. To measure the relative phase position of the signal from the ultrasonic pick-up as a function of its distance from the ultrasonic generator (which is in the sine mode), and to determine the ultrasonic wavelength and the phase velocity when the frequency is known.
2. To determine the oscilloscope's coefficient of sweep with the aid of the ultrasonic frequency.
3. With the generator in the pulsed mode, to record the delay time of the generator as a function of the distance between a generator and the pick-up, and to determine the group velocity.

What you can learn about

- Longitudinal waves
- Velocity of sound in liquids
- Wavelength
- Frequency
- Piezoelectric effect
- Piezoelectric ultrasonics transformer

Main articles

Ultrasonic generator	13920-99	1
30 MHz digital storage oscilloscope with colour display, 2 x BNC cables l = 75 cm incl.	11462-99	1
Ultrasonic pickup	13920-00	1
Glass cell, 150x55x100 mm	03504-00	1
Optical profile bench l = 60 cm	08283-00	1
Slide mount for optical bench, h = 80 mm	08286-02	1
Distributor	06024-00	1

Related Experiment

Temperature dependence of the velocity of ultrasound in liquids

P2151200

Velocity of sound in air with Universal Counter

P2150305

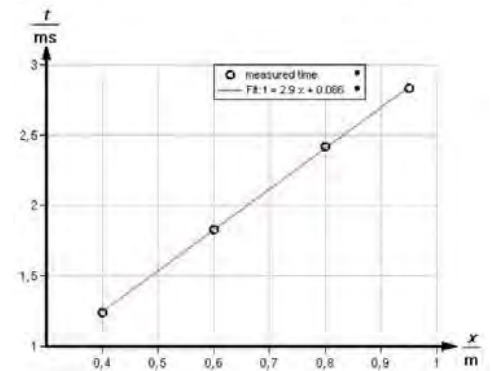

Propagation time as function of distance: measurements and fitted function.

Principle

The velocity of sound in air is determined by measurement of sound travel times across known distances.

Task

Determine the sound velocity in air for different distances between sound source and microphone.

What you can learn about

- Wave propagation
- Longitudinal wave
- Air pressure variation
- Sound wave
- Impulse of sound

Main articles

Universal Counter	13601-99	1
Measuring microphone w.amplifier	03543-00	1
Barrel base PHYWE	02006-55	2
Support	09906-00	1
Support rod with hole, stainless steel, 10 cm	02036-01	2
Measuring tape, l = 2 m	09936-00	1
Flat cell battery, 9 V	07496-10	1

Universal Counter



Function and Applications

The universal counter is used for measuring time, frequency, pulse rates, pulse counting, periodic times, speeds and velocities.

Benefits

- The device has all the qualities that are expected of a modern universal counter and is also equipped with a number of technical specifics of how it specifically arise from the requirements of science teaching practice.
- For the scientifically correct representation of each measurement is shown in principle with the associated unit. With the overflow of the display is automatically switched into the next area.
- Before the measurement starts it can be manually adjusted to a maximum of 6 decades defined range, e.g. to suppress is not physically meaningful digits on the display.
- A special jack for direct connection of a GM counter tube is available for radioactivity experiments. The required voltage can be changed manually to determine the characteristics of a counter tube too.

13601-99

P2150605 Velocity of sound using Kundt's tube and digital function generator

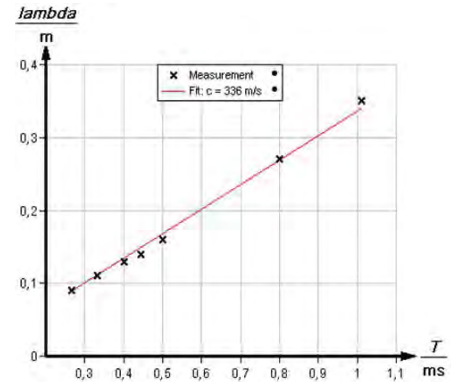
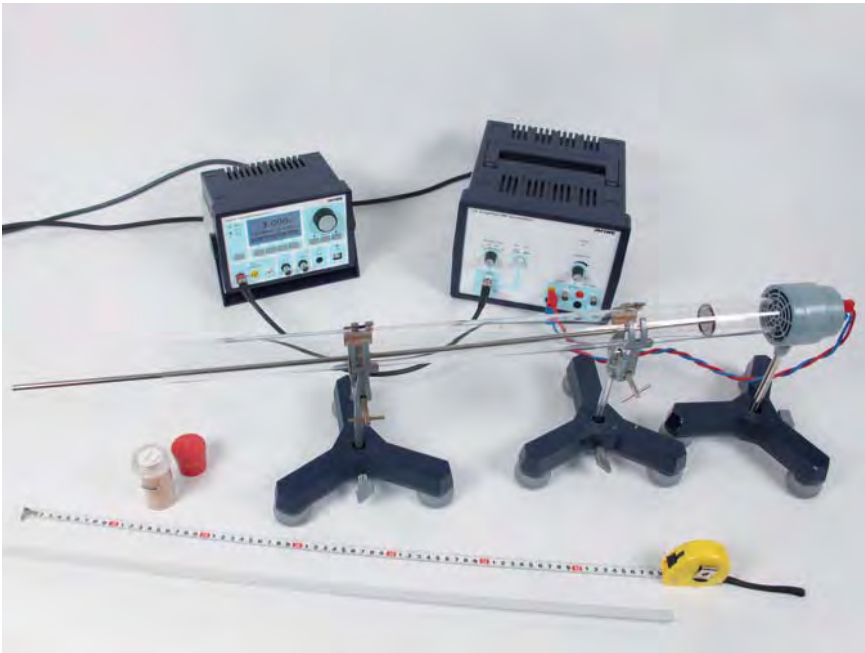

Determination of the velocity of sound at a tube length of $l = 615$ mm.

Principle

Cork dust in a glass tube is set into tiniest motion by a sound wave. If the frequency of the sound wave matches the natural frequency of the volume in the glass tube, a standing wave will form. The cork dust then assembles in visible patterns that show the nodes of pressure and motion of the standing wave. From the length of the volume and the number of the nodes the velocity of sound in the tube can be calculated for each natural frequency.

Task

Determine the velocity of sound in air using Kundt's tube at different lengths of volume.

What you can learn about

- Longitudinal waves
- Sound velocity in gases
- Frequency
- Natural frequency
- Wavelength
- Stationary waves

Main articles

LF amplifier, 220 V	13625-93	1
Digital Function Generator, USB, incl. Cobra4 Software	13654-99	1
Loudspeaker/Sound head	03524-00	1
Tripod base PHYWE	02002-55	3
Kundt's apparatus	03475-88	1
Thermometer -10...+50 C	38034-00	1
Screened cable, BNC, l 750 mm	07542-11	1

Related Experiment

Velocity of sound using Kundt's tube

P2150601

LF amplifier, 220 V

Function and Applications

For amplifying direct and alternating voltage up to 100 kHz. Can be used for induction experiments and for examining acoustic and electromagnetic fields. Signal output for the amplified measured signal.

Benefits

- Effective value output for display of the effective value of the signal output voltage.
- Power amplifier 12.5 W for weak acoustic frequency signals to control low resistance loudspeakers.
- For signals from frequency generators or computer interfaces.
- Amplification is continuously adjustable.

Equipment and technical data

- Ampl. factor: 0.1...10000, continuously adjustable
- Input impedance: 50 kOhm/ AC, 100 kOhm/ D
- Input voltage: -10 V...+10 V; Frequency range: 3.5 Hz....200 kHz,

13625-93

Acoustic Doppler effect with universal counter

P2150405

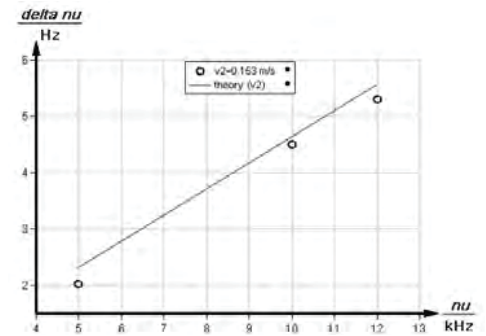

Comparison of the measured values with calculated values for a detector moving towards the emitter.

Principle

If an emitter of sound or a detector is set into motion relative to the medium of propagation, the frequency of the waves that are emitted or detected is shifted due to the Doppler effect.

Tasks

1. Measure the Doppler shift for varying frequencies and velocities for a moving sound emitter. Compare the measurements with the values predicted by theory and validate equation (4).
2. Measure the Doppler shift for varying frequencies and velocities for a moving detector. Compare the measurements with the values predicted by theory and validate equation (6).

Related Topics

- Wave propagation
- Doppler shift of frequency

Main articles

Universal Counter	13601-99	1
Digital Function Generator, USB, incl. Cobra4 Software	13654-99	1
Car, motor driven	11061-00	1
Measuring microphone w. amplifier	03543-00	1
Loudspeaker/Sound head	03524-00	1
Light barrier, compact	11207-20	1
Track, l 900 mm	11606-00	1

Car, motor driven



Function and Applications

For the experimental investigation of uniform movements and introduction of the concept of speed.

Benefits

- Drive: integrated battery powered electric motor (with radio noise suppression).
- Sliding switch for continuous speed adjustment; forward and backward switches, 4-wheel drive.
- Recess with clamping spring to attach holding bolt 03949-00.
- Eccentric clamps to attach recording tape for recording timer 11607-00.

Equipment and technical data

- Same chassis as measurement and experimenting car 11060-00.
- Dimensions without wheels (mm): 114×53×64.

11061-00

P2152415 Ultrasonic Doppler effect (with Cobra3)

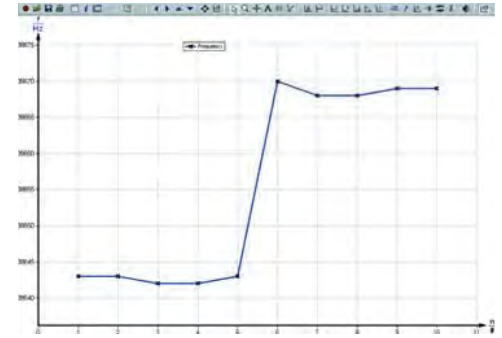

Doppler shift of frequency.

Principle

If a source of sound is in motion relative to its medium of propagation, the frequency of the waves that are emitted is displaced due to the Doppler effect.

Task

The frequency changes are measured and analysed for different relative velocities of source and observer.

What you can learn about

- Propagation of sound waves
- Superimposition of sound waves
- Doppler shift of frequency
- Longitudinal waves

Main articles

Cobra3 BASIC-UNIT, USB	12150-50	1
Ultrasound operation unit	13900-00	1
Car, motor driven	11061-00	1
Ultrasonic transmitter	13901-00	1
Ultrasonic receiver on stem	13902-00	1
Light barrier, compact	11207-20	1
Track, l 900 mm	11606-00	1

Cobra4 Experiment - available 2013

Ultrasonic Doppler effect (with Cobra4)

P2152460

Ultrasound operation unit



Function and Applications

Ultrasound operation unit.

Benefits

- Microprocessor controlled quartz-stabilised operation unit for ultrasonic transmitter and receiver.
- Adjustable output amplitude, 2 DIN sockets, one with 180° phaseshift, continuous and burst mode operation.
- 1 synchronous BNC output for delay time measurement.
- Input signal amplifier with 3 main amplifications and fine adjustment with one BNC-socket for oscilloscope.
- Overload warning LED allows adaption of ultrasound intensity to the experiment.
- Ideally suited for ultrasound experiments with large distances between transmitter and receiver, e.g. Doppler-effect with ultrasound.
- Fail-safe housing.

13900-00

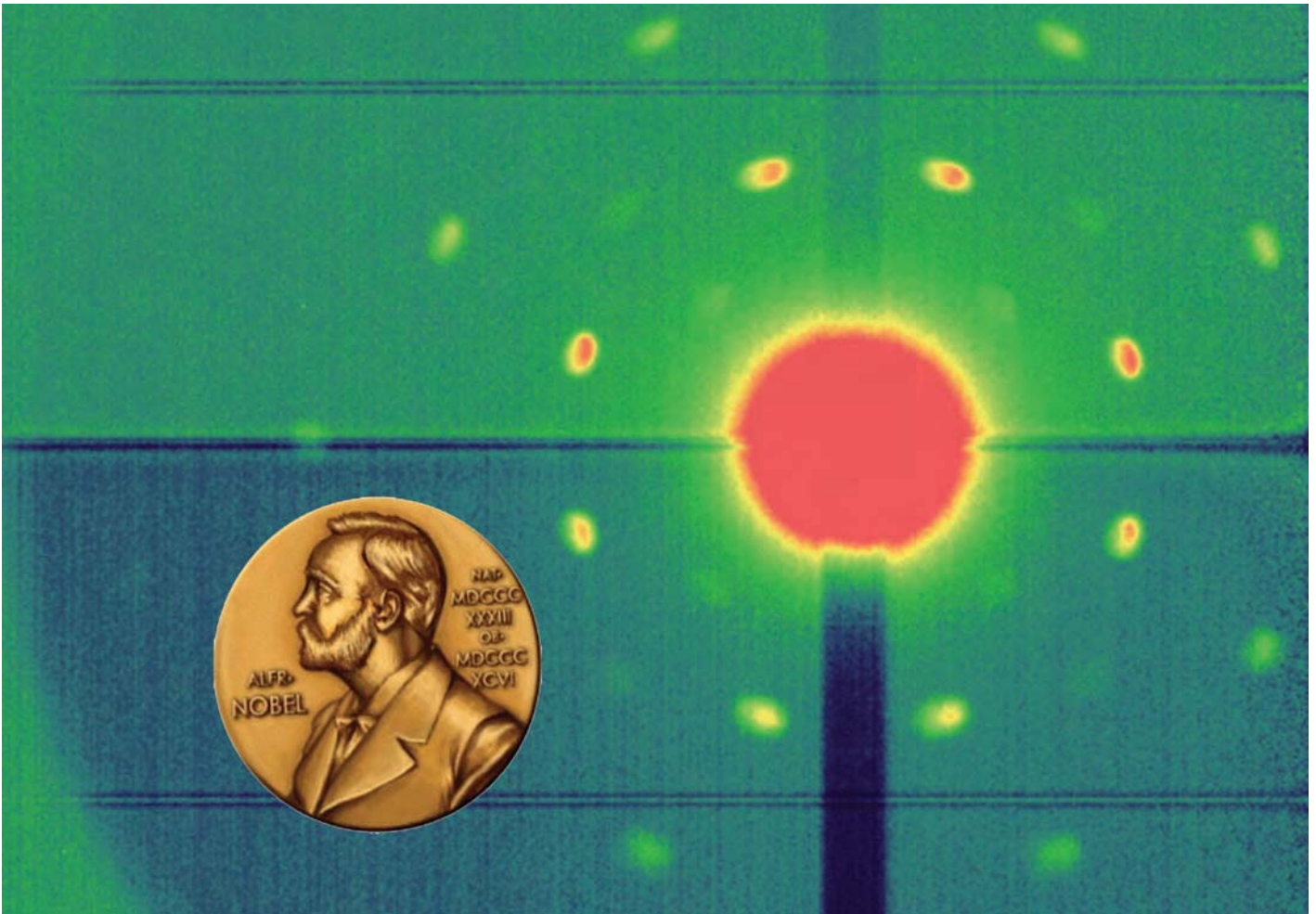

Materials Science

3.1	Mechanical Properties	44
3.2	Magnetic Properties	47
3.3	Thermal and Electrical Properties	50
3.4	X-ray Structural Analysis	58
3.5	X-ray Fluorescence Analysis	64
3.6	Nanotechnology	67
3.7	Metallography	77

P5160900 Shear waves in solid state materials

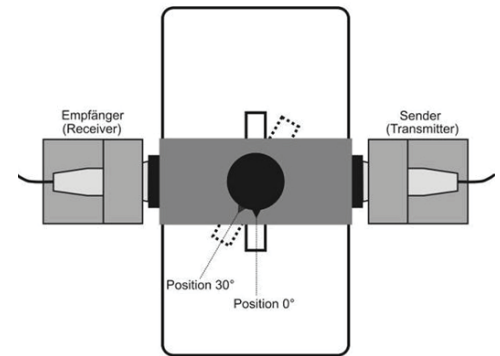
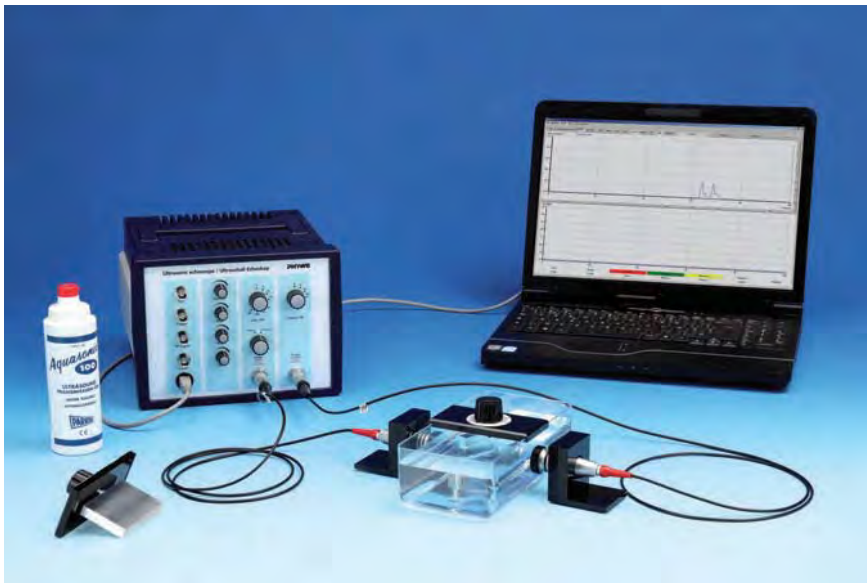

Schematic set-up with an indication of the angular positions.

Principle

The aim of this experiment is to study the generation and propagation of ultrasound waves in solid objects. In addition, the additional generation of transverse wave modes (shear wave modes) resulting from an oblique angle of incidence should be identified and the sound velocities for the longitudinal and transverse component should be determined. The relationship between the coefficients of elasticity of the material and its sound velocities enables the determination of the magnitude of the coefficients.

Tasks

1. Determine the sound amplitude of an ultrasound wave passing through an acrylic glass plate (transmission measurement) as a function of the angle of incidence for the longitudinal and transverse component.
2. Use the measurement curves to determine the longitudinal sound velocity in acrylic glass based on the angle of the total reflection, and the transverse sound velocity based on the amplitude maximums and the angle of the total reflection.
3. Determine the sound amplitude of an ultrasound wave passing through an aluminium plate (transmission measurement) as a function of the angle of incidence for the longitudinal and transverse component.
4. Use the measurement curves to determine the longitudinal sound velocity in aluminium, based on the angle of the total reflection, and the transverse sound velocity based on the angle of the amplitude maximums and the angle of the total reflection.
5. Based on the transverse and longitudinal sound velocities, calculate the coefficient of elasticity for acrylic glass and aluminium.

What you can learn about

- Ultrasonic transmission measurement
- Propagation of ultrasound waves
- Ultrasound wave modes

- Shear waves; Sound velocity
- Longitudinal and transverse waves
- Modulus of elasticity

Main articles

Basic Set Ultrasonic echoscope	13921-99	1
Extension set: Shear waves	13921-03	1
Vernier calliper stainless steel 0-160 mm, 1/10	03010-00	1
Ruler, plastic, 200 mm	09937-01	1

Extension set: Shear waves

Function and Applications

When an ultrasonic wave hits a solid state material in a certain angle, shear waves will be generated with increasing angle. Shear waves have a sound velocity differing to that of longitudinal waves. With this experimental equipment the transition from longitudinal to shear waves can be measured angle-dependently.

Benefits

Basics of ultrasounds which can not be demonstrated with industrial equipment are shown in a very didactical manner.

Equipment and technical data

- 1x Ultrasonic probe 1 MHz
- 1x Shear wave set (incl. 2 probe holders)
- 1x Aluminium sample for shear waves
- 1x Hydrophone for sound field measurement
- 1x Hydrophone plate; 1x Hydrophone holder
- 1x Holder block

13921-03

Torsional vibrations and torsion modulus

P2133000

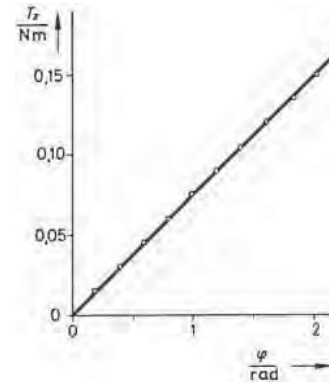

Torque and deflection of a torsion bar.

Principle

Bars of various materials will be exciting into torsional vibration. The relationship between the vibration period and the geometrical dimensions of the bars will be derived and the specific shear modulus for the material determined.

Tasks

1. Static determination of the torsion modulus of a bar.
2. Determination of the moment of inertia of the rod and weights fixed to the bar, from the vibration period.
3. Determination of the dependence of the vibration period on the length and thickness of the bars.
4. Determination of the shear modulus of steel, copper, aluminium and brass.

What you can learn about

- Shear modulus; Angular velocity
- Torque; Moment of inertia
- Angular restoring torque
- G-modulus
- Modulus of elasticity

Main articles

Torsion apparatus	02421-00	1
Spring Balance 1 N	03060-01	1
Spring balance 2,5 N	03060-02	1
Torsion rod, Al, l = 500 mm, d = 4 mm	02421-06	1
Torsion rod, Al, l = 500 mm, d = 3 mm	02421-05	1
Sliding weight	03929-00	2

Related Experiment

Mechanical hysteresis

P2120300

Torsion apparatus



Function and Applications

Apparatus for fixation of torsion rods.

Equipment and technical data

- Lever arm length: 370 mm
- Scale diameter: 300 mm; Scale division: 0...±180°

02421-00

Modulus of elasticity

P2120200



For more details refer to page 14.

Principle

A flat bar is supported at two points. It is bent by the action of a force acting at its centre. The modulus of elasticity is determined from the bending and the geometric data of the bar.

Tasks

1. Determination of the characteristic curve of the dial gauge.
2. Determination the bending of flatbars as a function of the force; at constant force: of the thickness, of the width and of the distance between the support points.
3. Determination the modulus of elasticity of steel, aluminium and brass.

Moments

P2120100



For more details refer to page 16.

Principle

Coplanar forces (weight, spring balance) act on the moments disc on either side of the pivot. In equilibrium, the moments are determined as a function of the magnitude and direction of the forces and of the reference point.

Tasks

1. Determination of the moment as a function of the distance between the origin of the coordinates and the point of action of the force.
2. Determination of the moment as a function of the angle between the force and the position vector to the point of action of the force.

Hooke's law (with Cobra4)

P2130160



Principle

The validity of Hooke's law is proven using various helical springs with different spring constants. In comparison, the behaviour of a stretched rubber band is examined, for which there is no proportionality between acting force and resulting extension.

Tasks

1. Measurement of the tensile force as a function of the path for three different helical springs and a rubber band.
2. Determination of the spring constant and evaluation of a hysteresis curve.

For more details refer to page 19.

Ferromagnetic hysteresis (with Cobra4)

P2430760

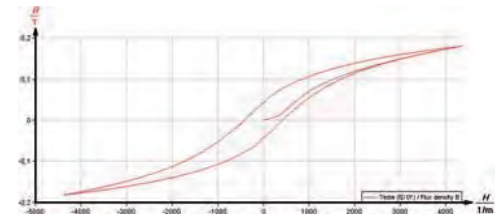

Hysteresis for a massive iron core.

Principle

A magnetic field is generated in a ring-shaped iron core by a continuous adjustable direct current applied to two coils. The field strength H and the flux density B are measured and the hysteresis recorded. The remanence and the coercive field strength of two different iron cores can be compared.

Task

Record the hysteresis curve for a massive iron core and for a laminated one.

What you can learn about

- Induction
- Magnetic flux
- Coil
- Magnetic field strength
- Magnetic field of coils
- Remanence
- Coercive field strength

Main articles

Cobra4 Wireless Manager	12600-00	1
Cobra4 Wireless-Link	12601-00	2
Cobra4 Sensor Tesla, magnetic field strength, resolution max. ± 0.01 mT	12652-00	1
Cobra4 Sensor-Unit Electricity, Current ± 6 A / Voltage ± 30	12644-00	1
Software Cobra4 - multi-user licence	14550-61	1
Power supply, universal	13500-93	1
Hall probe, tangential, protection cap	13610-02	1

Related Experiment

Ferromagnetism, paramagnetism and diamagnetism

P1221300

Cobra4 Sensor Tesla, magnetic field strength, resolution max. ± 0.01 mT



Function and Applications

Sensor out of the Cobra4 family to measure the magnetic field strength in DC and AC fields. This Sensor is suitable for the connection of the Hall probes.

Benefits

- Connection of two different Hall probes possible: tangential and axial
- Exceptionally good resolution
- Measurement of the earth's magnetic field possible

12652-00

P2430800 Magnetostriction with the Michelson interferometer

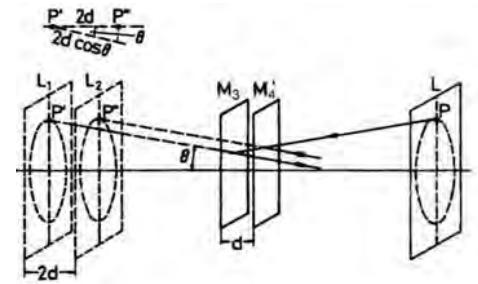

Formation of circular interference fringes.

Principle

With the aid of two mirrors in a Michelson arrangement, light is brought to interference. Due to the magnetostrictive effect, one of the mirrors is shifted by variation in the magnetic field applied to a sample, and the change in the interference pattern is observed.

Tasks

1. Construction of a Michelson interferometer using separate optical components.
2. Testing various ferromagnetic materials (iron and nickel) as well as a non-ferromagnetic material (copper), with regard to their magnetostrictive properties.

What you can learn about

- Interference
- Wavelength
- Diffraction index
- Speed of light
- Phase
- Virtual light source
- Ferromagnetic material
- Weiss molecular magnetic fields
- Spin-orbit coupling

Main articles

He/Ne Laser, 5mW with holder	08701-00	1
Power supply for laser head 5 mW	08702-93	1
Power supply, universal	13500-93	1
Optical base plate with rubberfeet	08700-00	1
Faraday modulator f.opt.base pl.	08733-00	1
Rods for magnetostriction, set	08733-01	1
Adjusting support 35 x 35 mm	08711-00	3

Power supply for laser head 5 mW

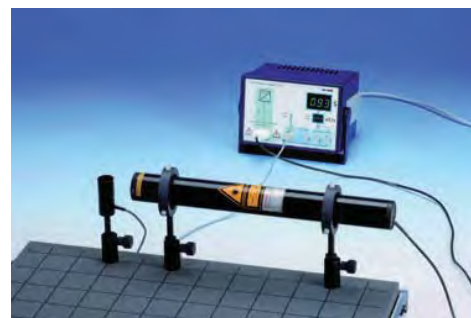

Function and Applications

High voltage power supply for lasers, e. g. the 5 mW laser (08701-00).

Equipment and technical data

- With programmable timer for selection of exposure time of holograms between 0.1 ... 99 s.
- With a controllable shutter.
- Digital display for preset shutter times as well as those which have already occurred.
- Shutter control via time select, new start, stop and shutter open (permanent open).
- Dimensions of plastic housing (mm): 184 x 140 x 130.
- Incl. shutter with fixed connection cord with unit plug on holding rod.
- Rod diameter: 10 mm.

08702-93

Investigate in magnetic micro and nano structures by Magnetic Force Microscopy (MFM)

P2538500

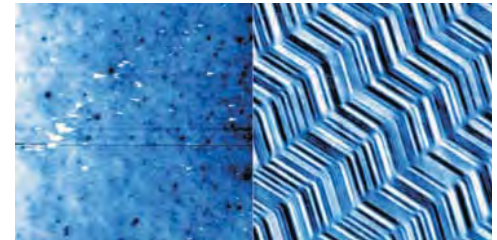

Digital Data Storage (DAT) tape: Topography (left, 50 μm) and phase contrast image (right, 50 μm) at same location. The phase contrast image contains the magnetic information and shows a stripe-like structure with a mean feature size of 3 μm (one bit).

Principle

Magnet interaction between the tip and sample is used to image magnetic structures with Atomic Force Microscopy (AFM). The principle of magnetic force microscopy can be shown scanning an backup tape (DAT). For this a magnetic tip is used and is magnetized with an ultra-magnet along a certain direction to be sensitive on different direction of magnetic field lines. After imaging the topography in contact mode the cantilever is retracted a few 10 nm. At this distance magnetic force dominates the interaction between cantilever and tape. Scanning the same area it leads to stripe-like structures showing the magnetization of the tape. Also magnetic structures for data storage on floppy disks (ZIP or others) or hard disk down to a structure size of a few ten nanometer can be imaged and analyzed.

Tasks

1. Set-up the microscope, magnetize the magnetic coated tip along a certain direction and approach the tip to the sample in phase imaging mode. Take a topography image.
2. Retract the tip a few 10 nm to do a MFM measurement for different distances. Magnetize the tip to another direction and compare and interpret the results.
3. Image the magnetic structures of different samples, e.g. floppy disk, ZIP floppy disk, and hard disk.

What you can learn about

- Magnetic forces
- Magnetic Force Microscopy (MFM)
- Imaging of magnetic nano structures
- Nano magnetics
- Magnetic data storage
- Phase contrast imaging
- Vibration amplitude
- Resonance shift

Main articles

Compact-Atomic Force Microscope (AFM)	09700-99	1
Material upgrade, for compact atomic force microscope	09701-00	1

Training recommended

Service | PHYWE

For this experiment we recommend a seminar on equipment technology, handling and information of equipment-specific characteristics on site.

03333-02

P2310100 Thermal expansion in solids and liquids

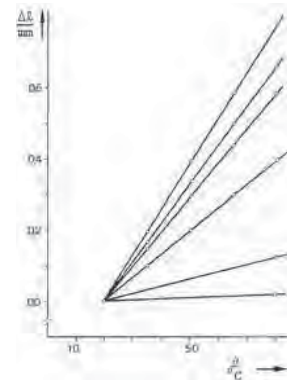
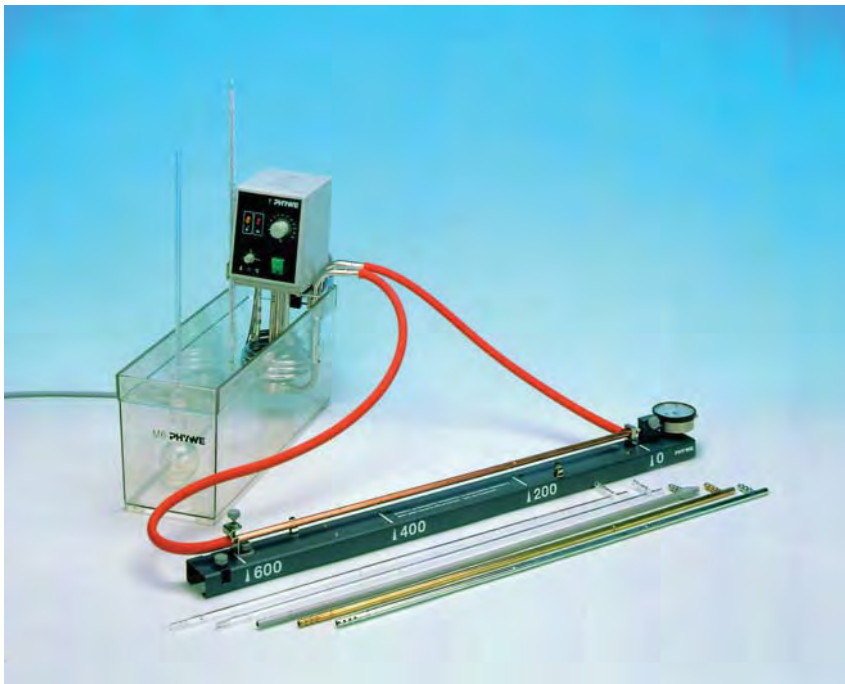

Relationship between length l and temperature, for a) aluminium, b) brass, c) copper, d) steel, e) duran glass, f) quartz glass ($l_0 = 600$ mm).

Principle

The volume expansion of liquids and the linear expansion of various materials is determined as a function of temperature.

Tasks

1. To determine the volume expansion of ethyl acetate (C₄H₈O₂), methylated spirit, olive oil, glycerol and water as a function of temperature, using the pycnometer.
2. To determine the linear expansion of brass, iron, copper, aluminium, duran glass and quartz glass as a function of temperature using a dilatometer.
3. To investigate the relationship between change in length and overall length in the case of aluminium.

What you can learn about

- Linear expansion
- Volume expansion of liquids
- Thermal capacity
- Lattice potential
- Equilibrium spacing
- Grüneisen equation

Main articles

Immersion thermostat Alpha A, 230 V	08493-93	1
Dilatometer with clock gauge	04233-00	1
Bath for thermostat, makrolon	08487-02	1
Tube, quartz for 04231-01	04231-07	1
Measuring tube, $l = 300$ mm, IGJ 19/26	03024-00	2
Aluminium tube for 04231-01	04231-06	1
Set of Precision Balance Sartorius CPA 423S and measure software, 230 V	49223-88	1

Related Experiments

Thermal expansion in solids

P2310200

Thermal expansion in liquids

P2310300

Dilatometer with clock gauge



Function and Applications

Dilatometer with clock gauge on baseplate (730x50x25 mm) for the quantitative measurement of the linear expansion of solid bodies depending on material, length and temperature.

04233-00

Heat capacity of metals

P2330101

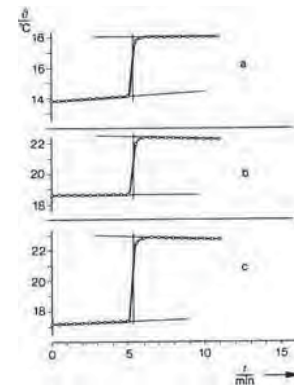

Temperature as a function of time in the method of mixtures experiment a) steel, b) brass, c) aluminium.

Principle

Heated specimens are placed in a calorimeter filled with water at low temperature. The heat capacity of the specimen is determined from the rise in the temperature of the water.

Tasks

1. To determine the heat capacity of the calorimeter by filling it with hot water and determining the rise in temperature.
2. To determine the specific heat capacity of aluminium, iron and brass.
3. To verify Dulong Petit's law with the results of these experiments.

What you can learn about

- Mixture temperature
- Boiling point
- Dulong Petit's law
- Lattice vibration
- Internal energy
- Debye temperature

Main articles

Calorimeter, 500 ml	04401-00	1
Aneroid barometer	03097-00	1
Butane burner, Labogaz 206 type	32178-00	1
Thermometer -10...+50 °C	38034-00	1
Stopwatch, digital, 1/100 s	03071-01	1
Metal bodies, set of 3	04406-00	4
Set of Precision Balance Sartorius TE 601 and measure software balances, 230V	48837-88	1

Cobra4 Experiment - available 2013

Heat capacity of metals (with Cobra4)

P2330160



P2350200 Thermal and electrical conductivity of metals



Principle

The thermal conductivity of copper and aluminium is determined in a constant temperature gradient from the calorimetrically measured heat flow. The electrical conductivity of copper and aluminium is determined, and the Wiedmann-Franz law is tested.

Tasks

1. Determine the heat capacity of the calorimeter in a mixture experiment as a preliminary test. Measure the calefaction of water at a temperature of 0 °C in a calorimeter due to the action of the ambient temperature as a function of time.
2. To begin with, establish a constant temperature gradient in a metal rod with the use of two heat reservoirs (boiling water and ice water). After removing the pieces of ice, measure the calefaction of the cold water as a function of time and determine the thermal conductivity of the metal rod.
3. Determine the electrical conductivity of copper and aluminium by recording a current-voltage characteristic line.
4. Test of the Wiedmann-Franz law.

What you can learn about

- Electrical conductivity; Wiedmann-Franz law; Lorenz number
- Diffusion; Temperature gradient; Heat transport
- Specific heat; Four-point measurement

Main articles

Temperature meter digital, 4-2	13617-93	1
Universal measuring amplifier	13626-93	1
Multitap transformer, 14 VAC/ 12 VDC, 5 A	13533-93	1
Surface temperature probe PT100, -20...+300°C	11759-02	2

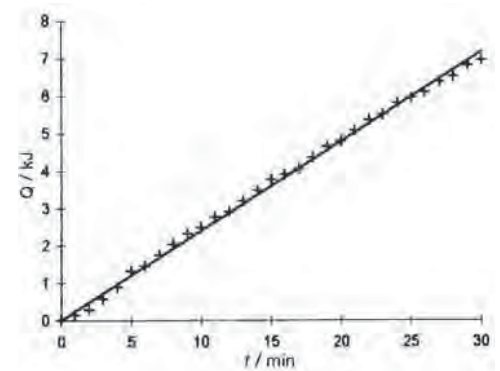

Diagram: Heat of surroundings over time.

Rheostat, 10 Ohm , 5.7A	06110-02	1
Heat conductivity rod, Cu	04518-11	1
Magnetic stirrer Mini / MST	47334-93	1

Temperature meter digital, 4-2

Function and Application

Modern, user-friendly designed instrument for measuring temperature and temperature differences at four different measuring points.

Benefits

- Two demonstrative 4 digit LED display (+ sign), with 20 mm high digits for presentation of the values measured at the selected measuring points.
- RS 232 interface for simultaneous display and evaluation of the measured values from all four measuring points with a computer.
- Measurements of temperature difference between two probes in any combination.
- Tare function (set 0.00) with a ten times better resolution in a wide range on each side of the newly set zero.
- Automatic compensation of probe differences with an adjust function.
- Change over between °C and K; temperature difference values and tared values are automatically presented in K.

13617-93

Temperature dependence of different resistors and diodes (with Cobra4)

P2410460

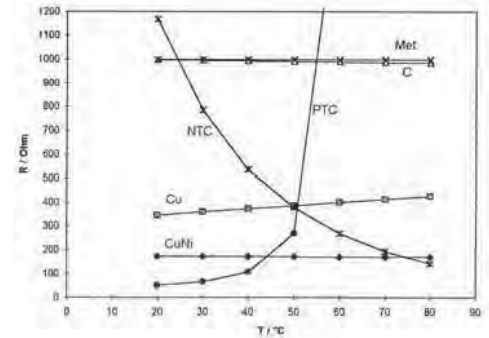
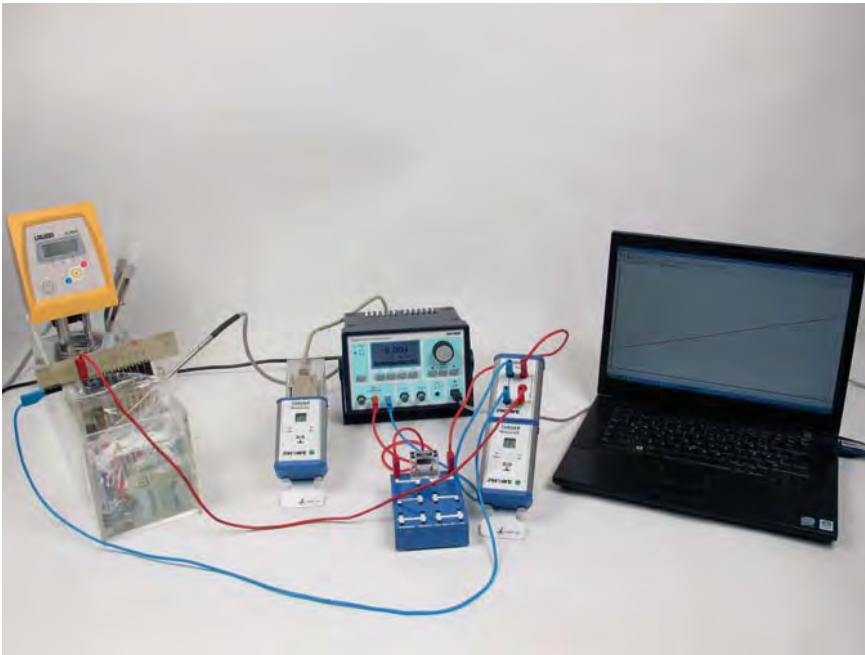

Diagram of resistances.

Principle

The temperature dependence of an electrical parameter (e.g. resistance, conducting-state voltage, blocking voltage) of different components is determined. To do this, the immersion probe set is immersed in a water bath and the resistance is measured at regular temperature intervals.

Tasks

1. Measurement of the temperature dependence of the resistance of different electrical components.
2. Measurement of the temperature dependence of the conducting state voltage of semiconducting diodes.
3. Measurement of the temperature dependence of the voltage in the Zener and the avalanche effects.

What you can learn about

- Carbon film resistor; Metallic film resistor
- PTC; NTC; Z diode; Avalanche effect
- Zener effect; Charge carrier generation
- Free path; Mathie's rule

Main articles

Cobra4 Wireless Manager	12600-00	1
Cobra4 Wireless-Link	12601-00	2
Cobra4 Sensor-Unit Energy current, voltage, power, energy	12656-00	1
Software Cobra4 - multi-user licence	14550-61	1
Immersion probes for determining ct	07163-00	1
Immersion thermostat Alpha A, 230 V	08493-93	1
Bath for thermostat, makrolon	08487-02	1

Related Experiment

Temperature dependence of different resistors and diodes with a multimeter

P2410401

Immersion probes for determining ct



Function and applications

10 components for determining temperature dependence (up to max. 100 °C) of characteristic parameters such as resistance, conducting-state voltage and off-state voltage.

07163-00

P2530300 Hall effect in metals

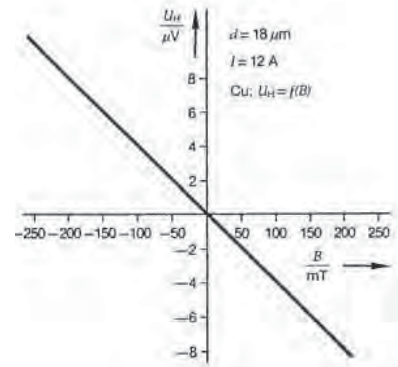
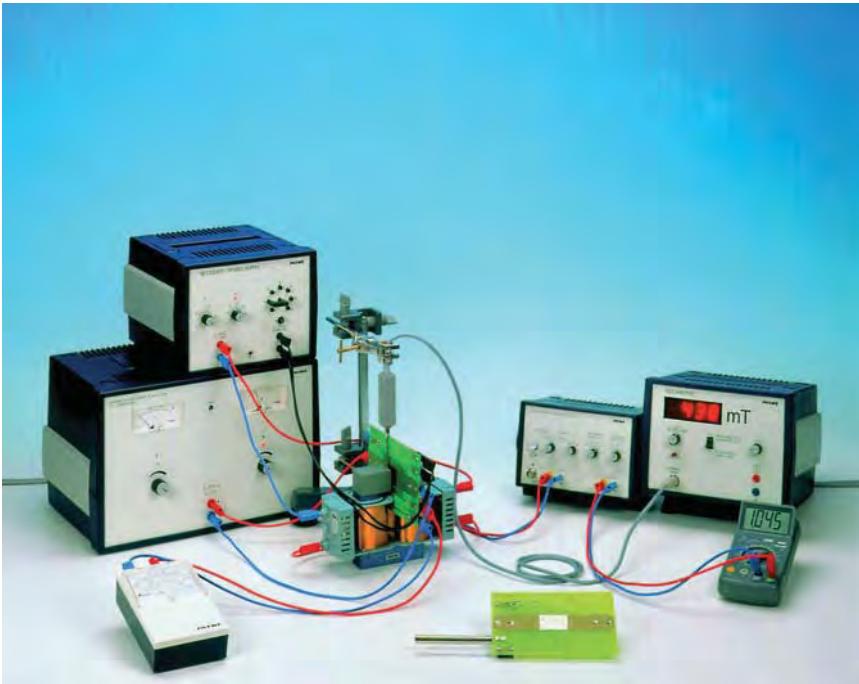

Hall voltage as a function of magnetic induction B, using a copper sample.

Principle

The Hall effect in thin zinc and copper foils is studied and the Hall coefficient determined. The effect of temperature on the Hall voltage is investigated.

Tasks

1. The Hall voltage is measured in thin copper and zinc foils.
2. The Hall coefficient is determined from measurements of the current and the magnetic induction.
3. The temperature dependence of the Hall voltage is investigated on the copper sample.

What you can learn about

- Normal Hall effect
- Anomalous Hall effect
- Charge carriers
- Hall mobility
- Electrons
- Defect electrons

Main articles

Power supply 0-30VDC/20A, stabil	13536-93	1
Teslameter, digital	13610-93	1
Universal measuring amplifier	13626-93	1
Power supply, universal	13500-93	1
Hall effect, Cu, carrier board	11803-00	1
Hall effect, zinc, carrier board	11804-01	1
Hall probe, tangential, protection cap	13610-02	1

Universal measuring amplifier



Function and Applications

Universal measuring amplifier for amplification of AC and DC voltages. Suitable for practical exercises.

Equipment and technical data

Input impedance:

Electrometer: > 10 (13) Ohm

Low drift: 10 kOhm

- input voltage: -10 to + 10 V
- output voltage: -10 to + 10 V

Frequency ranges:

- V=1 0...100 kHz; V=10 0... 75 kHz; V=10(2) 0... 10 kHz
- V=10(3) 0... 6 kHz; V=10(4) 0...2.5 kHz; V=10(5) 0... 2 kHz
- Mains voltage: 230 V AC; Dimensions: 194 x 140 x 126 mm

13626-93

Hall effect in p-germanium

P2530101

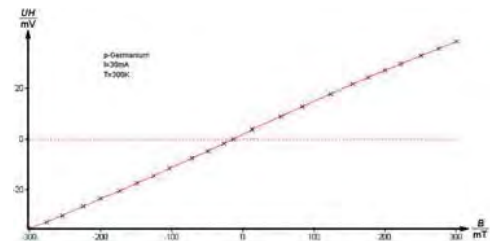

Hall voltage as a function of magnetic induction.

Principle

The resistivity and Hall voltage of a rectangular germanium sample are measured as a function of temperature and magnetic field. The band spacing, the specific conductivity, the type of charge carrier and the mobility of the charge carriers are determined from the measurements.

Tasks

1. The Hall voltage is measured at room temperature and constant magnetic field as a function of the control current and plotted on a graph (measurement without compensation for defect voltage).
2. The voltage across the sample is measured at room temperature and constant control current as a function of the magnetic induction B .
3. The voltage across the sample is measured at constant control current as a function of the temperature. The band spacing of germanium is calculated from the measurements.
4. The Hall voltage U_H is measured as a function of the magnetic induction B , at room temperature. The sign of the charge carriers and the Hall constant R_H together with the Hall mobility m_H and the carrier concentration p are calculated from the measurements.
5. The Hall voltage U_H is measured as a function of temperature at constant magnetic induction B and the values are plotted on a graph.

What you can learn about

- Semiconductor; Band theory; Forbidden zone
- Intrinsic conductivity
- Extrinsic conductivity; Valence band
- Conduction band
- Lorentz force; Magnetic resistance
- Mobility; Conductivity; Band spacing; Hall coefficient

Main articles

Teslameter, digital	13610-93	1
Hall effect module	11801-00	1
Hall effect, p-Ge, carrier board	11805-01	1
Power supply 0...12 V DC/ 6 V, 12 V AC, 230 V	13505-93	1
Hall probe, tangential, protection cap	13610-02	1
Coil, 600 turns	06514-01	2
Iron core, U-shaped, laminated	06501-00	1

Related Experiment

Hall effect in n-germanium

P2530201

Cobra4 Experiments - available 2013

Hall effect in p-germanium (with Cobra4)

P2530160

Hall effect in n-germanium (with Cobra4)

P2530260

P2260106 Faraday effect with optical base plate

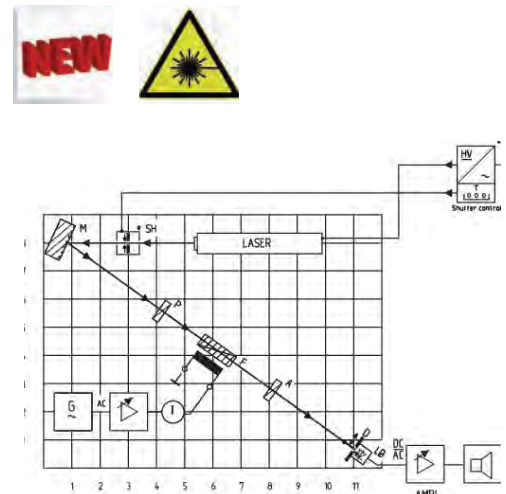

Experimental setup.

Principle

When the Faraday effect was discovered in 1845 it was the first experiment that elucidated the relation of light and electromagnetism. If linearly polarized light passes through a region with magnetic field the angle of rotation of the plane of polarization is altered. This alteration appears to be a linear function of both the average magnetic flow density and the distance that the wave covers in the magnetic field. The factor of proportionality is a medium specific constant and is called Verdet's constant.

Task

Investigate the Faraday effect qualitatively through observation of the electro optical modulation of the polarized laser light with frequencies in the acoustic range.

What you can learn about

- Interaction of electromagnetic fields, Electro magnetism
- Polarisation, Verdet's constant
- Malus' law, Electronic oscillation

Main articles

Digital Function Generator, USB, incl. Cobra4 Software	13654-99	1
Laser, He-Ne, 0.2/1.0 mW, 230 V AC	08180-93	1
Universal measuring amplifier	13626-93	1
Optical base plate with rubberfeet	08700-00	1
Faraday modulator f.opt.base pl.	08733-00	1
Loudspeaker, 8 Ohm/5 kOhm	13765-00	1

Related Experiment

Faraday effect

P2260100

Digital Function Generator, USB, incl. Cobra4 Software



Function and Applications

Digital signal generator for use as a programmable voltage source in practical or demonstration experiments, particularly in the disciplines of acoustics, electrical engineering and electronics.

Benefits

- Can be used as universal stand-alone device or controlled via a USB interface
- Universally applicable thanks to broad, continually adjustable frequency range
- Usable as programmable voltage source via amplifier output
- Intuitive, menu-driven operation using control knob and function buttons, with help capability
- Illuminated monochrome graphic display for maximum visibility and readability
- Simple setting of voltage and frequency ramps in stand-alone mode.

13654-99

Dielectric constant of different materials

P2420600

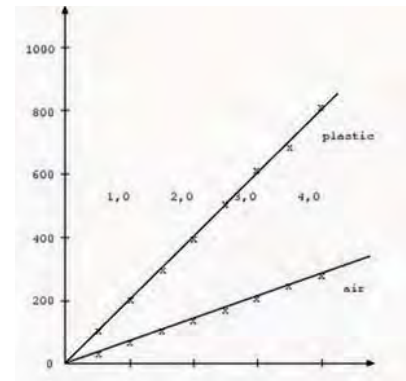

Electrostatic charge Q of a plate capacitor as a function of the applied voltage U_C , with and without dielectric (plastic) between the plates ($d = 0.98$ cm).

Principle

The electric constant is determined by measuring the charge of a plate capacitor to which a voltage is applied. The dielectric constant is determined in the same way, with plastic or glass filling the space between the plates.

Tasks

1. The relation between charge Q and voltage U is to be measured using a plate capacitor.
2. The electric constant is to be determined from the relation measured under point 1.
3. The charge of a plate capacitor is to be measured as a function of the inverse of the distance between the plates, under constant voltage.
4. The relation between charge Q and voltage U is to be measured by means of a plate capacitor, between the plates of which different solid dielectric media are introduced. The corresponding dielectric constants are determined by comparison with measurements performed with air between the capacitor plates.

What you can learn about

- Maxwell's equations; Electric constant
- Capacitance of a plate capacitor
- Real charges; Free charges
- Dielectric displacement, polarisation and constant

Main articles

High voltage supply unit, 0-10 kV	13670-93	1
Plate capacitor, d 260mm	06220-00	1
Universal measuring amplifier	13626-93	1
Voltmeter, 0.3-300VDC, 10-300VAC /	07035-00	1
Plastic plate 283 x 283 mm	06233-01	1

High-value resistor, 10 M Ω	07160-00	1
Glass plates f.current conductors	06406-00	1

High voltage supply unit, 0-10 kV



Function and Applications

For electrostatic experiments and for operation of spectral and gas discharge tubes.

Equipment and technical data

- It supplies 3 continuously variable DC voltages isolated from earth and ground. Two of the voltages are connected in series 0-5 kV DC = total of 0 -10 kV DC.
- Selectable positive and negative polarity. 3-figure LED display.
- Outputs short-circuit proof. Special safety sockets.
- Modern plastic housing, impact resistant, easy to service, light stackable with retractable carrying handle and stand.

13670-93

XRE 4.0 expert set – Details at a glance

Experience the perfect synthesis of innovative technology, highest level of safety, well-proven PHYWE quality and modern design. Extensive performance characteristics and ideas make working with the PHYWE XR 4.0 a special experience. We have presented some device highlights for you here.

Tube XChange Technology

- Self-adjusting X-ray tubes with quick-change technology
- Contact protection against hot parts
- 4 anode materials for specific experiments (W, Mo, Cu, Fe)



Touch Panel

- Simultaneous control, manually and by computer
- Interactive, intuitive handling
- Self-explanatory icons for fast operation

3View – Insight provides a transparent view

- Exceptional observability of the experimentation space
- Extra-large window front on 3 sides (Diagonals: 18"/18"/14", 46cm/46cm/36cm)



XXL Chamber

- Large space for large experiments
- Temperature-controlled, internally-ventilated experimentation space



Optical bench with riders

- Radiography experiments
- Simple, precise positioning of optical components



S-Lock – new PHYWE Safety interlock

- Electrical and mechanical safety lock
- Prevents door opening with switched on X-radiation
- Thus offers the highest possible safety
- Patent pending

Goniometer (not pictured)

- Self-calibrating
- Collision protected
- Easy, safe handling



MultiLINK

- Connection field internal and external
- USB 2.0, N₂, BNC, XRED, Aux, etc.
- No annoying „cable-laying“
- In addition, extra-large cable conduit

High-resolution TFT backlit display

- Diagonal 4.3“
- 480 x 272 Pixel
- 16 Bit, 65.536 colors
- With LED lighting
- Optimal, dynamic representation of all important device parameters and measured values

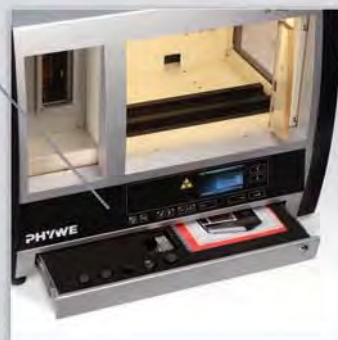

Safekeeping drawer

- All accessories are kept safely and always ready at hand
- Lockable

XR 4.0 expert unit – Sets for all applications

Basic set	Core components (incl. further Accessories)	Areas of application	Application examples
XR 4.0 expert set Art. No. 09110-88 (Basic set)	<ul style="list-style-type: none"> XR 4.0 expert unit (X-ray device) Tungsten tube (W) XR measure 4.0 X-ray software Optical bank TESS expert manual Fluorescent screen USB cable, mains cable + adaptor 		<ul style="list-style-type: none"> Basics & applications of X-radiation Radiographic experiments Radiology

Extend the basic set with the respective extension set according to area of application

Extension sets (optional)	Core components (incl. further accessories)	Areas of application	Application examples
XRP 4.0 solid-state physics Art. No. 09120-88	<ul style="list-style-type: none"> Goniometer, GM counter tube LiF / KBr single crystal Absorption set 		<ul style="list-style-type: none"> Diffraction X-ray spectroscopy Bragg-reflection / Bremsstrahlung Characteristic lines
XRC 4.0 characterisation Art. No. 09130-88	<ul style="list-style-type: none"> 3 X-ray tubes (Cu, Fe, Mo) Goniometer, GM counter tube LiF / KBr single crystal 		<ul style="list-style-type: none"> Radiation spectrums of the anode Moseley law Rydberg constant Duane-Hunt law
XRS 4.0 structure analysis Art. No. 09140-88	<ul style="list-style-type: none"> Goniometer, GM counter tube LiF / KBr / NaCl single crystal Crystal holder Powder samples 		<ul style="list-style-type: none"> Structure investigations Laue patterns Debye-Scherrer recordings X-ray analysis
XRM 4.0 material analysis Art. No. 09160-88	<ul style="list-style-type: none"> Goniometer X-ray energy detector Multi channel analyser Sample sets 		<ul style="list-style-type: none"> X-ray fluorescence spectroscopy Non-destructive testing (NDT) Compton Effect Energy-dispersive experiments
XRI 4.0 radio photography Art.-No. 09150-88	<ul style="list-style-type: none"> Camera Radiographic object Model loader Implant model 		<ul style="list-style-type: none"> Basics for the X-ray image provision Radiography Radiology Non-destructive testing (NDT)
XRD 4.0 dosimetry and radiation damage Art. No. 09170-88	<ul style="list-style-type: none"> Parallel-plate capacitor Power supply unit 600 V DC current amplifier Camera 		<ul style="list-style-type: none"> Dosimetry Degradation Damage Ionisation of air
XRCT 4.0 computer tomography Art. No. 09180-88	<ul style="list-style-type: none"> Direct, digital X-ray image sensor Rotation unit, vertical rotation measure Tomography software package 		<ul style="list-style-type: none"> 3-dimensional reconstruction Sectional drawings in respective position Direct, digital image provision
XRW 4.0 wireless demonstration Art. No. 09115-88	<ul style="list-style-type: none"> Digital display panel Cobra4 Display-Connect Transmitter and receiver, etc. 		<ul style="list-style-type: none"> Demonstration experiments (operation without computers) Placard-style representation of the measured values and parameters

Examination of the structure of NaCl monocrystals with different orientations

P2541301

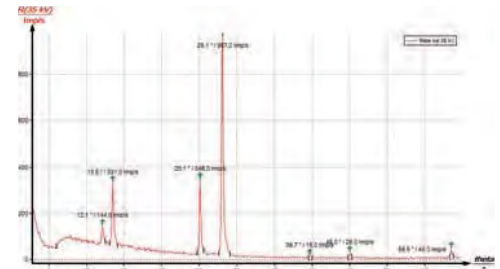

Intensity of the X-ray spectrum of copper as a function of the glancing angle theta: NaCl monocrystals with [111] crystal orientation as Bragg analyser.

Principle

The spectra of the X-rays that are reflected with various different orientations by NaCl monocrystals are analysed. The associated interplanar spacings are determined based on the Bragg angles of the characteristic lines.

Tasks

1. Determine the intensity of the X-rays that are reflected by the NaCl monocrystals with the orientations [100], [110], and [111] as a function of the Bragg angle.
2. Assign the reflections to the corresponding lattice planes that are given by way of their respective Miller indices.
3. Determine the lattice constant and calculate the interplanar spacing.
4. Determine the mass of a cell and the number of atoms in the cell.

What you can learn about

- Characteristic X-radiation
- Energy levels
- Crystal structures
- Reciprocal lattices
- Miller indices
- Atomic form factor
- Structure factor
- Bragg scattering

Main articles

XR 4.0 expert unit	09057-99	1
XR 4.0 X-ray goniometer	09057-10	1
XR 4.0 X-ray Plug-in Cu tube	09057-50	1
XR 4.0 X-ray NaCl-monocrystals, set of 3	09058-01	1
XR 4.0 Software measure X-ray	14414-61	1
Geiger-Mueller Counter tube, type B	09005-00	1

Best fitting X-ray sets for this experiment:

XR 4.0 X-ray expert set

09110-88

XRS 4.0 X-ray structural analysis upgrade set

09140-88

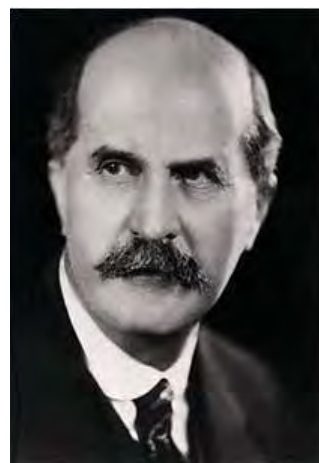

Sir William Henry Bragg (left) and Sir William Lawrence Bragg (right) 1915, Nobel Prize in Physics

P2541401 X-ray investigation of cubic crystal structures / Debye- Scherrer powder method

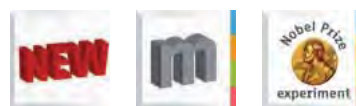

Debye-Scherrer pattern of a powdered sample of NaCl. Thickness of the sample: 0.4 mm. Exposure time: 2.5 h. Mo X-ray tube: $U_a = 35$ kV; $I_a = 1$ mA.

Principle

When polycrystalline samples are irradiated with X-rays a characteristic diffraction pattern results. These Debye-Scherrer reflections are photographed and then evaluated.

Tasks

1. Debye-Scherrer photographs are to be taken of powdered samples of sodium chloride and caesium chloride.
2. The Debye-Scherrer rings are to be evaluated and assigned to the corresponding lattice planes.
3. The lattice constants of the sample materials are to be determined.
4. The number of atoms in the unit cells of each sample are to be determined.

What you can learn about

- Crystal lattices
- Crystal systems
- Reciprocal lattice
- Miller indices
- Structure amplitude
- Atomic form factor
- Bragg scattering

Main articles

XR 4.0 expert unit	09057-99	1
XR 4.0 X-ray Plug-in Mo tube	09057-60	1
XR 4.0 X-ray film holder	09057-08	1
XR 4.0 X-ray optical bench	09057-18	1
XR 4.0 X-ray films, wet chemical, 100 pieces, 100 × 100 mm	09058-23	1
XR 4.0 X-ray Diaphragm tube d = 1 mm	09057-01	1

Slide mount for optical bench, h = 30 mm 08286-01 1

Related Experiment

X-ray investigation of hexagonal crystal structures / Debye-Scherrer powder method

P2541501

Best fitting X-ray sets for this experiment:

XRE 4.0 X-ray expert set

09110-88

XRS 4.0 X-ray structural analysis upgrade set

09140-88

X-ray investigation of crystal structures / Laue method with digital X-ray image sensor (XRIS)

P2541602

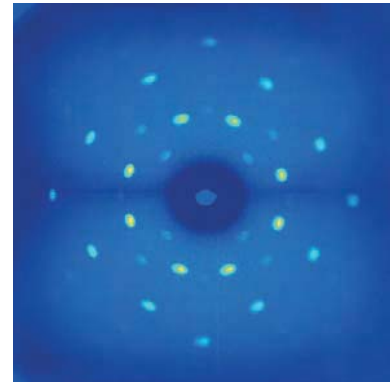
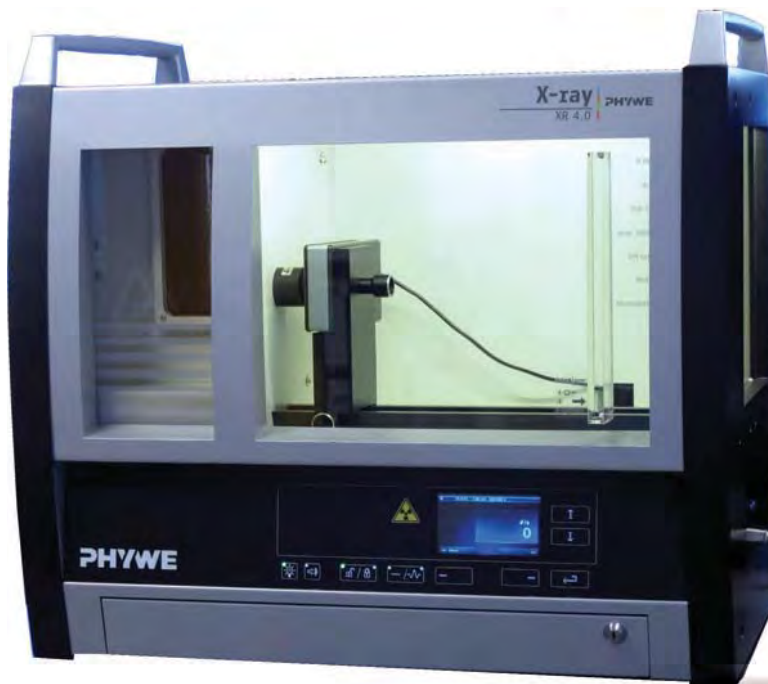

Laue pattern of the LiF (100) crystal.

Principle

Laue diagrams are produced when monocrystals are irradiated with polychromatic X-rays. This method is primarily used for the determination of crystal symmetries and the orientation of crystals. When a LiF monocrystal is irradiated with polychromatic X-rays, a characteristic diffraction pattern results. This pattern is photographed with the digital X-ray sensor XRIS.

Tasks

1. The Laue diffraction of an LiF monocrystal is to be recorded on a film.
2. The Miller indices of the corresponding crystal surfaces are to be assigned to the Laue reflections.

What you can learn about

- Crystal lattices; Crystal systems; Crystal classes
- Bravais lattice; Reciprocal lattice; Miller indices
- Structure amplitude; Atomic form factor; Bragg equation

Main articles

XR 4.0 X-ray Direct Digital Image Sensor (XRIS) with USB cable	09057-40	1
XR 4.0 expert unit	09057-99	1
XR 4.0 Software measure CT	14421-61	1
XR 4.0 X-ray plug-in unit W tube	09057-80	1
XR 4.0 X-ray Lithium fluoride crystal, mounted	09056-05	1
XR 4.0 X-ray optical bench	09057-18	1
XR 4.0 X-ray Crystal holder for Laue-pattern	09058-11	1

Related X-ray Experiment

X-ray investigation of crystal structures / Laue method

P2541601

Best fitting X-ray sets for this experiment:

XR 4.0 X-ray expert set

09110-88

XRCT 4.0 X-ray Computed Tomography upgrade set

09180-88

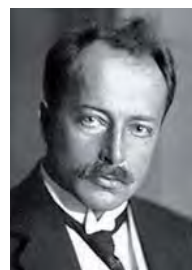

Max von Laue

1914, Nobel Prize in Physics

P2544701 Qualitative X-ray fluorescence analysis of powder samples

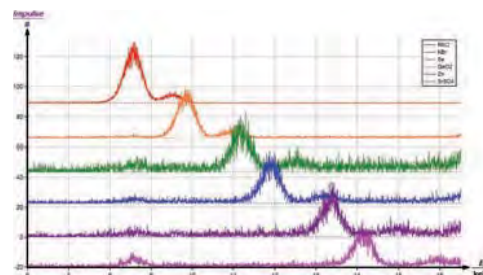

Total representation of the $K\alpha$ and $K\beta$ fluorescence lines of the elements with an atomic number of $30 < Z < 38$.

Principle

Various powder samples are subjected to polychromatic X-rays. The energy of the resulting fluorescence radiation is analysed with the aid of a semiconductor detector and a multichannel analyser. The energy of the corresponding characteristic X-ray fluorescence lines is determined. The elements of the samples are identified by comparing the line energies with the corresponding table values.

Tasks

1. Calibrate the semiconductor energy detector with the aid of the characteristic radiation of the tungsten X-ray tube.
2. Record the fluorescence spectra that are produced by the samples.
3. Determine the energy values of the corresponding fluorescence lines and compare the experimental energy values with the corresponding table values in order to identify the powder components.

What you can learn about

- Bremsstrahlung; Characteristic X-radiation
- Energy levels; Fluorescent yield
- Semiconductor energy detectors
- Multichannel analysers

Main articles

XR 4.0 expert unit	09057-99	1
XR 4.0 X-ray energy detector (XRED)	09058-30	1
XR 4.0 X-ray goniometer	09057-10	1
XR 4.0 X-ray plug-in unit W tube	09057-80	1
Multi channel analyser	13727-99	1
XR 4.0 X-ray Chemical set for edge absorption measure	09056-04	1
Software multi channel analyser	14452-61	1

Best fitting X-ray sets for this experiment:

XR 4.0 X-ray expert set

09110-88

XR 4.0 X-ray material analysis upgrade set

09160-88

Multi channel analyser



Function and Applications

The multi channel analyser is for analysing voltage pulses which are proportional to energy and for determining pulse rates and intensities in conjunction with an X-ray detector, alpha detector or gamma detector. The analogue pulses from the detector are shaped by the analyser, digitised and summed per channel according to pulse height. This results in a frequency distribution of detected pulses dependent on the energy of the radiation.

13727-99

Quantitative X-ray fluorescence analysis of alloyed materials

P2545001

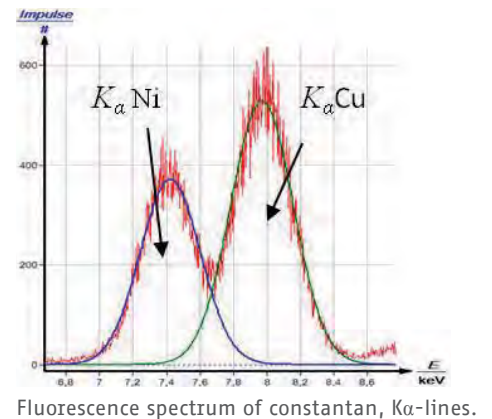

Principle

Various alloyed materials are subjected to polychromatic X-rays. The energy of the resulting fluorescence radiation is analysed with the aid of a semiconductor detector and a multichannel analyser. The energy of the corresponding characteristic X-ray fluorescence lines is determined. In order to determine the concentration of the alloy constituents, the intensity of their respective fluorescence signals is compared to that of the pure elements.

Tasks

1. Calibration of the semiconductor energy detector with the aid of the characteristic radiation of the tungsten X-ray tube.
2. Recording of the fluorescence spectra that are produced by the alloyed samples.
3. Recording of the fluorescence spectra that are produced by the pure metals.
4. Determination of the energy values of the corresponding fluorescence lines.
5. Calculation of the concentration levels of the alloy constituents.

What you can learn about

- Bremsstrahlung; Characteristic X-radiation
- Energy levels; Fluorescent yield; Auger effect
- Coherent and incoherent photon scattering
- Absorption of X-rays; Edge absorption
- Matrix effects; Semiconductor energy detectors
- Multi channel analysers

Main articles

XR 4.0 expert unit	09057-99	1
XR 4.0 X-ray energy detector (XRED)	09058-30	1
XR 4.0 X-ray goniometer	09057-10	1
XR 4.0 X-ray plug-in unit W tube	09057-80	1
Multi channel analyser	13727-99	1

XR 4.0 X-ray specimen set metals for fluorescence, set of 4	09058-34	1
XR 4.0 X-ray specimen set metals for X-ray fluorescence, set of 7	09058-31	1

Best fitting X-ray sets for this experiment:

XR 4.0 X-ray expert set

09110-88

XR 4.0 X-ray material analysis upgrade set

09160-88

XR 4.0 X-ray energy detector (XRED)



Function and Applications

With the new X-ray energy detector you can directly determine the energies of single x-ray quanta.

09058-30

Quantitative X-ray fluorescence analysis of solutions

P2545101

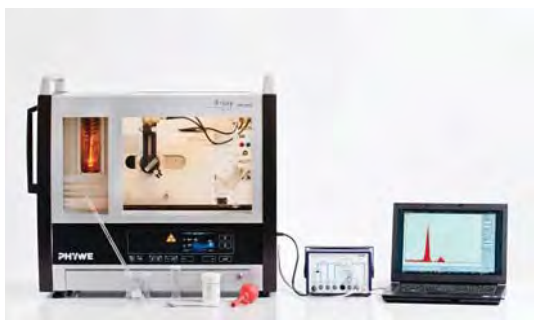

Principle

Various solutions, with known element concentrations, are subjected to polychromatic X-rays. The energy and intensity of the resulting fluorescence radiation of the dissolved elements are analysed with the aid of a semiconductor detector and a multichannel analyser. In order to determine the unknown element concentrations in the solutions, calibration is performed. For this purpose, the known element concentrations of the calibration solution are plotted against the corresponding fluorescence intensities of the dissolved elements.

For more details refer to www.phywe.com

Qualitative X-ray fluorescence spectroscopy of metals - Moseley's law

P2544501



Principle

Various metal samples are subjected to polychromatic X-rays. The energy of the resulting fluorescence radiation is analysed with the aid of a semiconductor detector and a multi channel analyser. The energy of the corresponding characteristic X-ray lines is determined, and the resulting Moseley diagram is used to determine the Rydberg frequency and the screening constants.

For more details refer to page 213.

Qualitative X-ray fluorescence analysis of alloyed materials

P2544601



Principle

The composition of various alloys is analysed with the aid of polychromatic X-rays. The energy of the characteristic fluorescence lines of the alloy constituents is analysed with the aid of a semiconductor detector and a multichannel analyser. The alloy constituents are identified by comparing the line energies with the corresponding table values.

For more details refer to www.phywe.com

Compact-Scanning Tunneling Microscope (STM)



Function and Applications

Easy to use scanning tunneling microscope to image conducting surfaces and to investigate effects and characteristics on atomic and molecular scale.

A variety of experiments in the fields of Material Sciences, Solid State Physics/Chemistry, Nanotechnology and Quantum Mechanics can be performed.

For example: micro- and nano- morphology of surfaces, nano structures, imaging of atoms and molecules, conductivity, tunneling effect, charge density waves, single molecule contacts, and nanostructuring by self organisation (self assembled monolayers).

Benefits

- Out-of-the-box-device incl. all necessary accessories for a prompt entry into the world of atoms and molecules
- Portable and compact: transportable, easy to install with a small footprint
- Single device for more stable measurements
- Quick atomic resolution on a normal table. No need for expensive vibration isolation
- Easy to use: Ideal for nanotechnology education, preparing students for their work on high-level research devices, and outreach
- Accessible sample stage and scanning tip: Quick exchange of tip and sample
- Low operating voltage: Safe for all users

Equipment and technical data

- Scan head with integrated control-unit on vibration-isolated experimentation board:
 - Maximum scan range (XY) 500 nm x 500 nm
 - Maximum Z-range 200 nm
 - Resolution in XY better than 8 pm
 - Resolution in Z better than 4 pm
 - Current 0.1-100 nA in 25 pA steps
 - Tip voltage +/-10 V in 5 mV steps
 - Dimensions 21 cm x 21 cm x 10 cm
 - Constant-Current Mode
 - Constant-Height Mode
 - Current-Voltage Spectroscopy
 - Current-Distant Spectroscopy
 - Control-Unit with USB socket, 16-Bit
 - DA converter for all three dimensions, up to 7 measurement channels, and maximum scanning speed of 60 ms/line

- Scan head cover with magnif. lense: 10 x
- Toolset for preparing and mounting tunneling tips: side-cutter, tong and tweezers
- Pt-Ir wire for tunneling tips: length 30 cm, diameter 0.25 mm
- Sample kit: Graphite (HOPG), Gold (111) films, and 4 spare sample supports
- Power supply (100-240V, 50/60 Hz)
- USB cable: length 3 m
- Aluminium case (44 cm x 32 cm x 14 cm)
- Software for measuring, analysing and visualization (one, two, and three dimensions)
- Handbook incl. short description of starting experiments with HOPG and gold films
- Quick Installation Guide
- Weight (incl. case) 6.7 kg

Accessories

- Computer with Windows 2000/XP/Vista/7, USB interface, 256 MB RAM, 1024x758 graphics card, 16-bit color resolution or better
- other samples
- electrical conductive adhesive for mounting own samples
- ethanol and cloth for cleaning

09600-99

Set samples nanomorphology, for Compact Scanning Tunneling Microscope (STM)



Function and Applications

Universal samples set to investigate the surface morphology of metals at the nanometer scale using the Compact Scanning Tunneling Microscope (09600-99).

Benefits

- Complete set to investigate different production and treatment conditions of different metal surface (polishing, etching, coining, rolling, tempering, annealing, ...).
- Suitable for preparation of individual samples due to included metal foils, samples supports, conductive glue, cutter and sample storage box.
- Clear and save storage of samples due to included samples storage box.

Equipment and technical Data

- 7 metal foils (gold, silver, tantalum, tin, aluminum) for more than 10 samples of each
- Coined sample
- Cutter, samples supports (10 pcs.); Conductive glue
- Storage box
- Table of content
- Quick introduction guide

09613-00

P2532000 Atomic Resolution of the graphite surface by STM (Scanning Tunnelling Microscope)

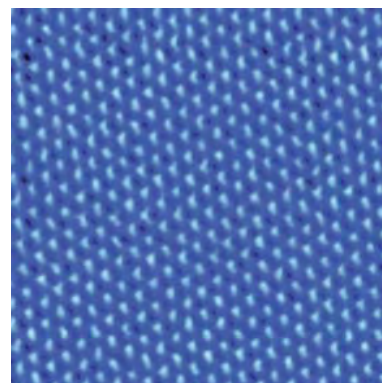

Atomic resolved image of the graphite surface (5 nm x 5 nm).

Principle

Approaching a very sharp metal tip to an electrically conductive sample by applying a electrical field leads to a current between tip and sample without any mechanical contact.

This so-called tunneling current is used to investigate the electronic topography on the sub nanometer scale of a fresh prepared graphite (HOPG) surface.

By scanning the tip line-by-line across the surface graphite atoms and the hexagonal structure are imaged.

Tasks

1. Prepare a Pt-Ir tip and the graphite (HOPG) sample and approach the tip to the sample.
2. Investigate the topography of clean terraces and the step height between neighboring terraces in constant-current mode.
3. Image the arrangement of graphite atoms on a clean terrace by optimize tunneling and scanning parameters. Interpret the structure by analyzing angles and distances between atoms and atomic rows and by using the 2D and 3D graphite model.
4. Measure and compare images in the constant-height and constant-current mode.

What you can learn about

- Tunneling effect
- Hexagonal structures
- Scanning Tunneling Microscopy (STM)
- Imaging on the sub nanometer scale
- Piezo-electric devices
- Local Density Of States (LDOS)
- Constant-Height-Mode
- Constant-Current-Mode

Main articles

Compact-Scanning Tunneling Microscope (STM)	09600-99	1
Crystal lattice kit: graphite	39840-00	1
Graphite model, 2D	09620-00	1

Related Experiments

Investigate in surface atomic structures and defects of different samples by STM

P2532500

Quantum Mechanics by STM - Tunneling Effect and Charge Density Waves

P2535000

Imaging and characterization of carbon-nanoarticle by STM (and STS)

P2536000

Training recommended



For this experiment we recommend a seminar on equipment technology, handling and information of equipment-specific characteristics on site.

03333-02

Self-assembled molecular networks of TMA and hexadecanol by STM

P2534500

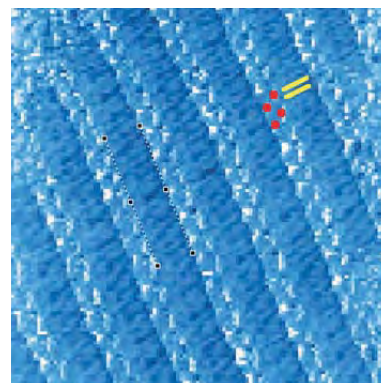

Alternating hexadecanol (indicated yellow) and TMA (indicated red) at the toluene HOPG interface. The distance between the dashed lines is 2.9 nm.

Principle

Approaching a very sharp metal tip to an electrically conductive sample and applying an electrical field leads to a current between tip and sample without any mechanical contact.

This so-called tunneling current is used to investigate the electronic topography on the sub nanometer scale of a fresh prepared graphite (HOPG) surface. Subsequent different mixtures of hexadecanol and TMA molecules solved in toluene or phenyloctane are applied to the surface investigating the self-assembly in the liquid interface.

Based on an actual scientific publication the structure of the resulting self assembled monolayer is analysed.

Tasks

1. Prepare a Pt-Ir tip and the samples. Approach the tip towards the sample.
2. Investigate the topography of the HOPG sample in constant-current mode.
3. Investigate the topography of adsorbed hexadecanol and trimelic acid molecules on the HOPG surface.
4. Interpret the results regarding the self-alignment of the molecules.

Related Topics

- Tunneling effect
- Scanning Tunneling Microscopy (STM)
- Constant-Current-Mode
- Imaging on the subnanometer scale
- Imaging in the liquid interface
- Self-assembly of molecules
- Self assembled monolayers (SAM)
- Interaction of molecules

Main articles

Compact-Scanning Tunneling Microscope (STM)	09600-99	1
---	----------	---

Related Experiment

Self-assembled molecular networks of arachin acid by STM

P2534000

Training recommended

Service | PHYWE

For this experiment we recommend a seminar on equipment technology, handling and information of equipment-specific characteristics on site.

03333-02

P2537000 Roughness and nanomorphology of different metal samples by STM

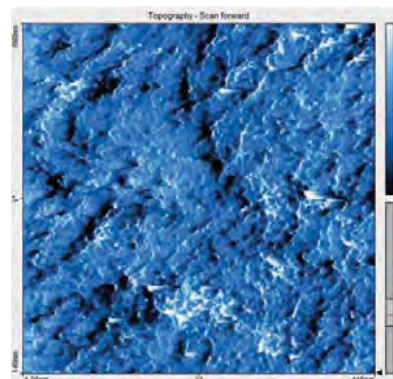

Topography of 1 euro cent coin (iron based alloy with copper coating).

Principle

Approaching a very sharp metal tip to an electrically conductive sample by applying a electrical field leads to a current between tip and sample without any mechanical contact. This so-called tunneling current is used to investigate the electronic topography on the subnanometer scale of a fresh prepared graphite (HOPG) surface. By scanning the tip line-by-line across the surface graphite atoms and the hexagonal structure are imaged.

Tasks

1. Prepare a Pt-Ir tip and the graphite (HOPG) sample and approach the tip to the sample.
2. Investigate the topography of clean terraces and the step height between neighboring terraces in constant-current mode.
3. Image the arrangement of graphite atoms on a clean terrace by optimize tunneling and scanning parameters. Interpret the structure by analysing angles and distances between atoms and atomic rows and by using the 2D and 3D graphite model.
4. Measure and compare images in the constant-height and constant-current mode.

What you can learn about

- Tunneling effect; Hexagonal structures
- Scanning Tunneling Microscopy (STM)
- Imaging on the sub nanometer scale
- Piezo-electric devices; Local Density Of States (LDOS)
- Constant-Height and Constant-Current Mode

Main articles

Compact-Scanning Tunneling Microscope (STM)	09600-99	1
Set samples nanomorphology, for Compact Scanning Tunneling Microscope (STM)	09613-00	1



Compact-Atomic Force Microscope (AFM)

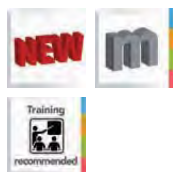

Function and Applications

Compact and easy to use atomic force microscope to visualize and image structures on the micro and nano meter scale. Developed for educational purposes in practical lab course and pre-research labs in physics, chemistry, life sciences and material sciences. Also suitable to determine material characteristics (e.g. stiffness, magnetization, charging, material and phase contrast) and for manipulation (e.g. lithography).

Benefits

- Out-of-the-box device with integrated damping plate and control unit underneath
- Complete set, incl. sample set, cantilever, tools and consumables
- Tip scanner AFM for standard cantilever
- Easy and safe cantilever exchange and use: Flip mechanism with automatic laser switch off
- No laser alignment, mechanical stopper for longer lifetime of cantilevers
- Digital top view camera for easy positioning and side view lens for easy and fast approach
- Portable and compact: Transportable, easy to install with a small footprint
- Easy to use: Ideal for nanotechnology education, preparing students for their work on high-level research devices, and outreach

Equipment and technical Data

- Scan head with integrated control-unit on vibration-isolated experimentation board: 21 cm x 21 cm x 18 cm, USB 2.0 interface, 16 bit DA converter (XYZ), 16 bit AD converter (7 channels)
- Max scanning speed 60 ms/line, up to 2048x2048 data points
- Scan type (tip scanner): Linear low voltage electro magnetic
- Scan Range: 70 μm (1.1 nm resolution)
- Z-range: 14 μm (1.1 nm resolution); Z noise level (RMS): 0.6 / 0.5 nm (static / dynamic); Automatic approach: vertical, range 4.5 mm
- Sample: max. 13 mm in diameter, horizontal mount, LED illumination; Micrometer translation stage xy: min. +/- 5 mm
- Cantilever Alignment: automatic adjustment, alignment grooves from various suppliers; Camera system for top view: USB digital color, 3.1 M pixels
- Modes of operation: Static Force, Dynamic Force, Force Distance Spectroscopy, Amplitude Distance Spectroscopy
- Other modes (MFM, AFM, Phase contrast, lithography and advanced spectroscopy modes)

- Available with upgrade options material and spectroscopy and manipulation
- User expandability (scripting) available (upgrade option); Set of 10 cantilever, 6 samples, toolset
- Software for measuring, manipulation, analysing and visualisation, Handbook and Quick Installation Guide

Accessories

- Material upgrade (Art. 09701-00): Additional Operating Modes (Phase Contrast, EFM, MFM, Force Modulation, Spreading Resistance), set of samples and cantilevers
- Spectroscopy and Manipulation upgrade (Art. 09702-00): Additional Operating Modes (Advanced Spectroscopy, Lithography (scratching, oxidation), Manipulation (oxidation, cutting and moving/pushing of nanoparticles)), User expandability (Visual basic, LabView, etc.), set of cantilevers and samples
- Side View Camera System (available 2013), other samples

09700-99

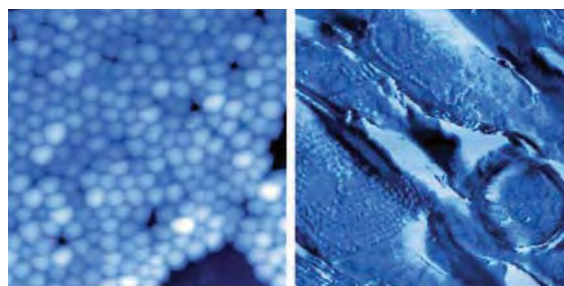

Staphylococcus Spec., 10 μm and skin cross-section, 60 μm .

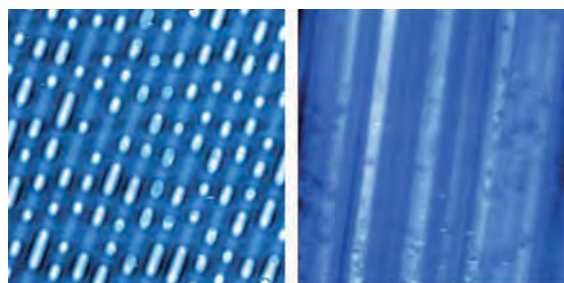

CD stamper, 20 μm and aluminum foil, 60 μm .

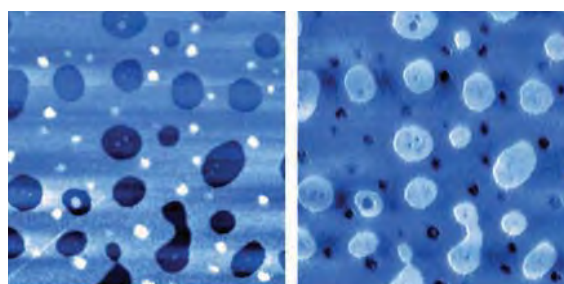

PS/PMMA films: Topography and phase contrast, 3 μm .

P2538000 Basic methods in imaging of micro and nanostructures with atomic force microscopy (AFM)

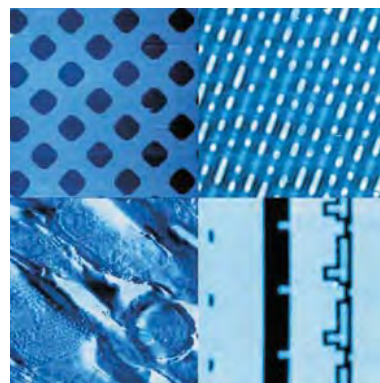

Topography of microstructure (50 μm), CD stamper (20 μm), skin cross-section (60 μm), and SCA chip structure (40 μm) FLTR.

Principle

Approaching a sharp silicon tip mounted on a cantilever to a sample surface leads to an atomic scale interaction. The result is a bend of the cantilever which is detected by a laser. In static mode the resulting deflection is used to investigate the topography of the sample surface line-by-line using a feedback loop. In dynamic mode the cantilever is oscillated at fixed frequency resulting in a damped amplitude near the surface. The measurement parameters (setpoint, feedback gain,...) play a crucial role for image quality. The dependence on the imaging quality is investigated for different nano structured samples.

Tasks

1. Set-up the microscope and start up the software. Mount a cantilever (with tip) and approach the tip towards a sample.
2. Investigate the influence of the scanning parameters on the imaging quality and performance, e.g. PID gain, setpoint (force), vibrational amplitude, and scanning speed. Use both static and dynamic force mode.
3. Image 7 different samples (microstructures, carbon nano tubes, skin cross-section, bacteria, CD stamper, chip structure, glass beads) by optimizing the parameters respectively.

What you can learn about

- Atomic Force Microscopy (AFM)
- Lennard-Jones potential
- Imaging of nano structures
- Static Force Mode
- Dynamic Force Mode
- Feedback loop
- Force
- Vibrational amplitude

Main articles

Compact-Atomic Force Microscope (AFM) 09700-99 1

Training recommended Service **PHYWE**

For this experiment we recommend a seminar on equipment technology, handling and information of equipment-specific characteristics on site.

03333-02

You need more information? WEB@ **PHYWE**
Just click www.phywe.com



Imaging of biological and medical micro and nanostructure with atomic force microscopy (AFM)

P2538400

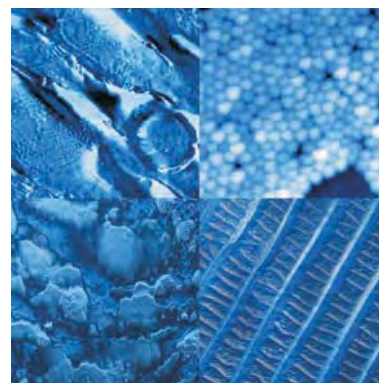

Topography of skin cross-section (60 μm), Staphylococcus bacteria (10 μm), human hair (40 μm), and butterfly wing (10 μm) FLTR.

Principle

Dynamic Atomic Force Microscopy is used to image and visualise several biological samples at a sub micrometer scale. A collection of both pre-prepared and freshly prepared samples are investigated, e.g. bacteria, skin cross-section, human hair, butterfly wing, blood cells, and fly eye. With high resolution imaging the relation between small biological structures and their function can be identified and different treatments could be recognised at this scale. One example is the imaging of different skin layers showing dead and living epithelial layer, collagen layer, hair follicle and structures within it. Another example is the imaging of different regular lattice structures to clarify the colour effect of butterfly wings.

Tasks

1. Set up the microscope and start up the software. Mount a cantilever and approach the tip towards a sample.

2. Use pre-prepared samples and investigate their topography by optimising the imaging parameters. Discuss the relation between the imaged structures with their function.

- Skin cross-section: different layers and their structures
- Staphylococcus bacteria: form, alignment and surface structure

3. Prepare different samples and investigate their topography by optimising the imaging parameters. Discuss the relation between the imaged structures with their function and treatment.

- Blood cells: different form and structure, function
- Butterfly wing: different regular structures, interference of light and colour effect
- Fly eye: compound of many "eye" units, resolution,

viewing angle, reaction time

- Human hair: treatment dependence of surface structure (coloured and non-coloured, wet and dry)

What you can learn about

- Atomic Force Microscopy
- Dynamic mode; Feedback loop
- High resolution 3D imaging
- Nano Imaging of biological and medical samples
- Relation of structure and function
- Blood cells; Butterfly wing; Insect eye
- Bacteria; Skin; Human hair

Main articles

Compact-Atomic Force Microscope (AFM)	09700-99	1
Sample support, 10 pcs, for Compact Scanning Tunneling Microscope and Atomic Force Microscope	09619-00	1
Cover glasses 18x18 mm, 50 pcs.	64685-00	1

Training recommended

Service **PHYWE**

For this experiment we recommend a seminar on equipment technology, handling and information of equipment-specific characteristics on site.

03333-02

P2538100 Basic methods in force spectroscopy to investigate material characteristics with atomic force microscopy (AFM)

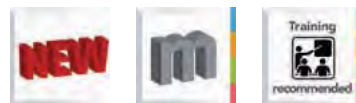

Sample (position)	Slope (mV/nm)	Slope (Nm)
Microstructure (terrace, 1)	0.072	0.260
Microstructure (pit, 2)	0.072	0.260
Carbon nanotube (tube, 3)	0.026	0.192
Carbon nanotube (background, 4)	0.023	0.180
Blood cells (red, 5)	0.041	0.194
Blood cells (white, 6)	0.032	0.192
Blood cells (erythrocytes, 7)	0.045	0.194
Human Hair (8)	0.012	0.180

Slopes of the Force-Distance-Curves for different materials showing different stiffnesses of the samples.

Principle

Approaching a sharp silicon tip mounted on a cantilever to a sample surface leads to atomic scale interaction caused by different kind of forces between tip and sample. The result is a bend of the cantilever which is detected by a laser. In force-distance spectroscopy the deflection is used to investigate the stiffness of the sample by applying a force to the tip, indenting the sample. In amplitude-distance spectroscopy the cantilever is oscillated at fixed frequency resulting in a damped amplitude near the surface. The damping as a function of tip-sample distance gives information about the derivative of the force between tip and sample and therefore the stiffness of the underlying material.

Tasks

1. Set-up the microscope and start up the software. Mount a cantilever and prepare a sample and approach the tip towards the sample. Take an AFM image of the sample and select different positions for force spectroscopy.
2. Use Force-Distance-Spectroscopy to reveal the system's deflection sensitivity for calibration purposes.
3. Use Force-Distance Spectroscopy to investigate different samples with respect to their mechanical stiffness.
4. Use Amplitude-Distance Spectroscopy mode to investigate the samples mechanical behavior and compare the results with Force-Distance measurements.

What you can learn about

- Atomic Force Microscopy (AFM)
- Atomic Force Spectroscopy
- Lennard-Jones potential
- Static force mode
- Dynamic force mode
- Mechanical force
- Stiffness
- Force-distance measurements

- Amplitude-distance measurements
- Nano mechanics

Main articles

Compact-Atomic Force Microscope (AFM)	09700-99	1
Sample support, 10 pcs, for Compact Scanning Tunneling Microscope and Atomic Force Microscope	09619-00	1
Cover glasses 18x18 mm, 50 pcs.	64685-00	1

Training recommended Service | PHYWE

For this experiment we recommend a seminar on equipment technology, handling and information of equipment-specific characteristics on site.

03333-02

Using the phase contrast mode to distinguish between different materials on the nano scale - Material contrast with AFM

P2538200

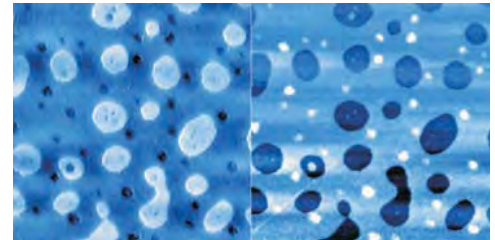

PS/PMMA films: Topography (left, 2.6 μm) and phase contrast image (right, 2.6 μm) at same location. The difference in material hardness visible in the phase contrast image clearly shows growth and wetting behaviour of material mixtures.

Principle

Dynamic Atomic Force Microscopy is used to image different heterogeneous sample surfaces at a sub micrometer scale.

Additionally the phase shift between the driving signal of the cantilever and the cantilever itself is recorded. The phase shift is connected with the energy dissipation involved in the contact between the tip and the sample, which depends on a number of factors, including such features as viscoelasticity and adhesion.

These dependencies lead to a material specific contrast (phase contrast) in phase shift images. A collection of samples are investigated with respect to their phase contrast.

This method is one of the most commonly used techniques for mechanical and composition characterisation of heterogeneous sample surfaces, e.g. polymers.

Tasks

1. Set-up the microscope, prepare sample and tip, and approach the tip to the sample in phase imaging mode. Optimise the parameters with respect to the imaging quality.
2. Investigate different heterogeneous sample surface with phase contrast imaging.
3. Compare and interpret the results.

What you can learn about

- Atomic Force Microscopy
- Dynamic mode
- Vibration amplitude
- Phase shift
- Phase contrast imaging
- Material contrast
- Polymers

Main articles

Compact-Atomic Force Microscope (AFM)	09700-99	1
---------------------------------------	----------	---

Material upgrade, for compact atomic force microscope

09701-00 1

Training recommended Service | PHYWE

For this experiment we recommend a seminar on equipment technology, handling and information of equipment-specific characteristics on site.

03333-02

P2538500 Investigate in magnetic micro and nanostructures by Magnetic Force Microscopy (MFM)

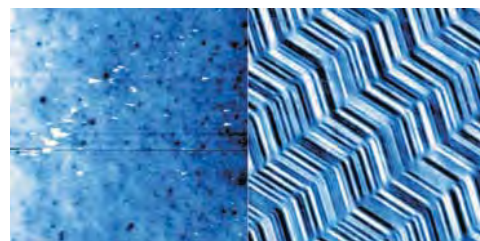

Digital Data Storage (DAT) tape: Topography (left, 50 μm) and phase contrast image (right, 50 μm) at same location. The phase contrast image contains the magnetic information and shows a stripe-like structure with a mean feature size of 3 μm (one bit).

Principle

Magnet interaction between the tip and sample is used to image magnetic structures with Atomic Force Microscopy (AFM). The principle of magnetic force microscopy can be shown scanning an backup tape (DAT). For this a magnetic tip is used and is magnetized with an ultra-magnet along a certain direction to be sensitive on different direction of magnetic field lines. After imaging the topography in contact mode the cantilever is retracted a few 10 nm. At this distance magnetic force dominates the interaction between cantilever and tape. Scanning the same area it leads to stripe-like structures showing the magnetisation of the tape. Also magnetic structures for data storage on floppy disks (ZIP or others) or hard disk down to a structure size of a few ten nanometer can be imaged and analysed.

Tasks

1. Set-up the microscope, magnetise the magnetic coated tip along a certain direction and approach the tip to the sample in phase imaging mode. Take a topography image.
2. Retract the tip a few 10 nm to do a MFM measurement for different distances. Magnetize the tip to another direction and compare and interpret the results.
3. Image the magnetic structures of different samples, e.g. floppy disk, ZIP floppy disk, and hard disk.

What you can learn about

- Magnetic forces
- Magnetic Force Microscopy (MFM)
- Imaging of magnetic nano structures
- Nano magnetics
- Magnetic data storage
- Phase contrast imaging
- Vibration amplitude
- Resonance shift

Main articles

Compact-Atomic Force Microscope (AFM)	09700-99	1
Material upgrade, for compact atomic force microscope	09701-00	1

Training recommended

Service | PHYWE

For this experiment we recommend a seminar on equipment technology, handling and information of equipment-specific characteristics on site.

03333-02

Metallographic sample preparation - grinding and polishing

P5510100

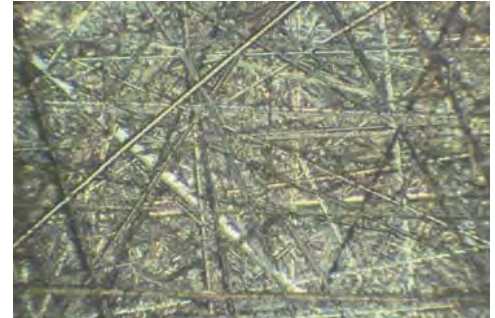

Surface condition of brass sample after step 1 (MD-Primo 220; Lubricant: water; Time: 2 min; Speed: 300 rpm): Magnification: 100x.

Principle

Metallography is the art of preparing metallic samples by grinding, polishing and eventual etching for subsequent microscopic examination. Grinding and polishing is to prepare the specimen surface so as to enable the microstructure to be revealed by a suitable etching procedure.

Tasks

1. Check the six metal specimens by means of the magnifier for any coarse defects.
2. Grind and polish the samples according to the general rules and the detailed instructions given, considering the hardness and ductility data and the basic processing guidelines specified.
3. Evaluate the influence of the individual process parameters on the surface quality obtained in the intermediate steps and after the final polishing.
4. Try to optimise the grinding and polishing procedures.

What you can learn about

- Grinding; Polishing
- Metallographic preparation; Ductility

Main articles

Grinding and polishing machine, 230 V 200/250 mm, 50-600 rpm, variable	70000-93	1
Ultrasonic cleaning bath, RK100H	46423-93	1
Diamantstick 6 µm, 25 g	70050-04	1
Grinding and polishing wheel Al, 200 mm	70000-11	1
Polishing cloth Ø 200 mm, METAPO-P, 10 pcs. for 10-6 micron diamonds	70002-03	1
Polishing cloth Ø 200 mm, METAPO-B, 10 pcs. for 3-1 micron diamonds	70003-03	1
Polishing cloth Ø 200 mm, METAPO-V, 10 pcs. for 1-0,1 micron diamonds	70004-03	1

Grinding and polishing machine, 230 V 200/250 mm, 50-600 rpm, variable



Function and application

Grinding and polishing machine to prepare metallographic samples.

Benefits

Variable grinding speed to prepare hard and soft samples.

Equipment and technical data

- Diameter grinding platen: 200 and 250 mm, respectively
- Speed: 50-600 rpm
- Connected power: 60 W
- Power supply : 230 VAC
- Dimensions (L x B x H): 380 x 690 x 340 mm
- Weight: 30 kg

70000-93

P5510200 Metallographic sample preparation - chemical etching

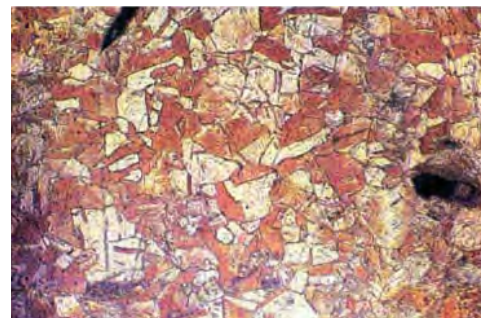
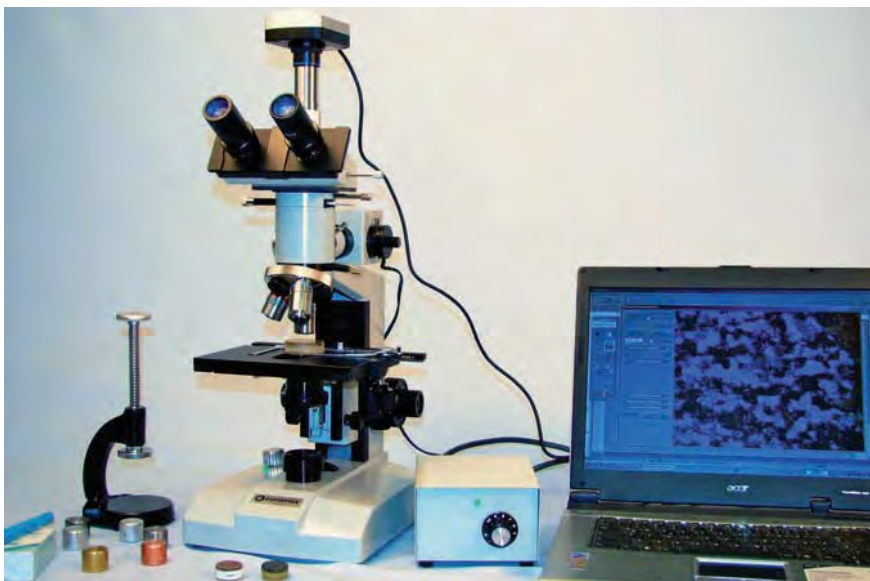

Copper, etched in sol. 5, grain contrast/precip. etching, magnification approx. 100x.

Principle

Chemical etching is the most common method for contrasting polished metal surfaces to reveal structural details of pure metals and alloys. The precondition for a good result in etching is a carefully polished and clean surface. The experiment describes the basic procedure, gives some recipes and presents a few pictures of several metal structures and phases.

Tasks

1. Check the six metal specimens polished by means of the microscope to see if any macroscopic or microscopic structural features can be noticed.
2. Prepare the etching solutions and etch the specimens according to the instructions.
3. Examine the specimen surfaces as to whether the structural details have been satisfactorily revealed.

What you can learn about

- Etching; Reveal crystallographic structure
- Micrography; Metallographic phases; Metal microscopy

Main articles

Microscope with incident and transmitted illumination set with USB CAM, 230 V for metallographic appl.	62244-88	1
Press for polished section	62244-15	1
Compact Balance, OHAUS TA 501, 500 g / 0.1 g, 230 V	49243-93	1
Sample set metallurgy containing 8 metall samples	70001-01	3
Labels GHS, blank, chemistry, 20 pcs.	38687-01	1
Isopropyl alcohol, 1000 ml	30092-70	1
Pasteur pipettes, 3 ml, PE, 500 pcs.	36616-00	1



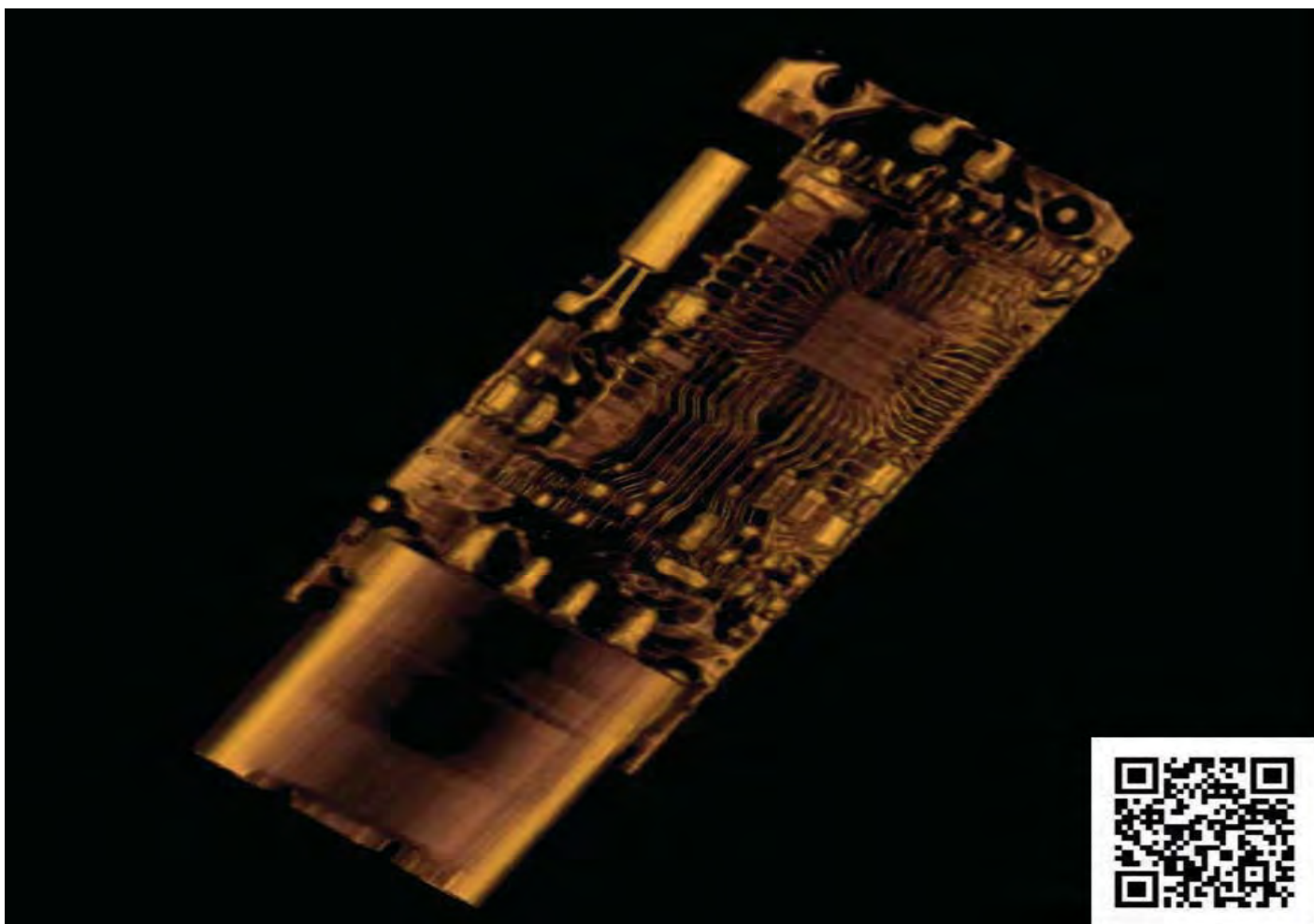

Non-destructive Testing (NDT)

4.1	X-ray Investigations	80
4.2	Ultrasonic Testing	90
4.3	Other Methods of NDT	102

4 Non-destructive Testing (NDT)

4.1 X-ray Investigations

XRE 4.0 expert set – Details at a glance

Experience the perfect synthesis of innovative technology, highest level of safety, well-proven PHYWE quality and modern design. Extensive performance characteristics and ideas make working with the PHYWE XR 4.0 a special experience.

We have presented some device highlights for you here.

Tube XChange Technology

- Self-adjusting X-ray tubes with quick-change technology
- Contact protection against hot parts
- 4 anode materials for specific experiments (W, Mo, Cu, Fe)



Touch Panel

- Simultaneous control, manually and by computer
- Interactive, intuitive handling
- Self-explanatory icons for fast operation

3View – Insight provides a transparent view

- Exceptional observability of the experimentation space
- Extra-large window front on 3 sides (Diagonals: 18"/18"/14", 46cm/46cm/36cm)



XXL Chamber

- Large space for large experiments
- Temperature-controlled, internally-ventilated experimentation space





Optical bench with riders

- Radiography experiments
- Simple, precise positioning of optical components

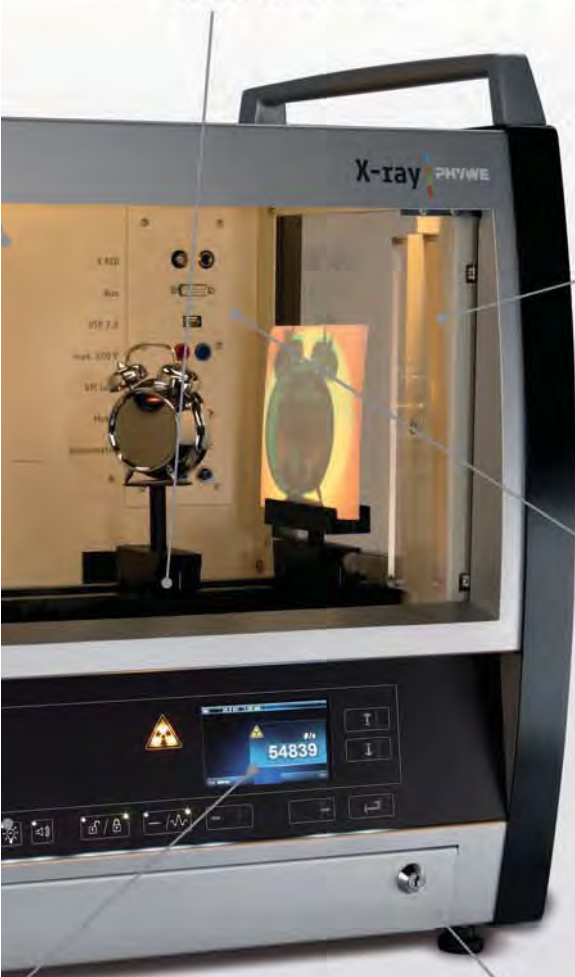

S-Lock – new PHYWE Safety interlock

- Electrical and mechanical safety lock
- Prevents door opening with switched on X-radiation
- Thus offers the highest possible safety
- Patent pending

Goniometer (not pictured)

- Self-calibrating
- Collision protected
- Easy, safe handling



MultiLINK

- Connection field internal and external
- USB 2.0, N₂, BNC, XRED, Aux, etc.
- No annoying „cable-laying“
- In addition, extra-large cable conduit

High-resolution TFT backlit display

- Diagonal 4.3“
- 480 x 272 Pixel
- 16 Bit, 65.536 colors
- With LED lighting
- Optimal, dynamic representation of all important device parameters and measured values

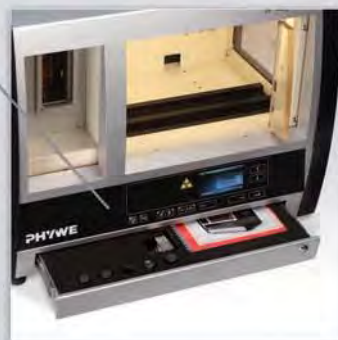

Safekeeping drawer

- All accessories are kept safely and always ready at hand
- Lockable

4 Non-destructive Testing (NDT)

4.1 X-ray Investigations

P2542001 Determination of length and position of an object which can not be seen

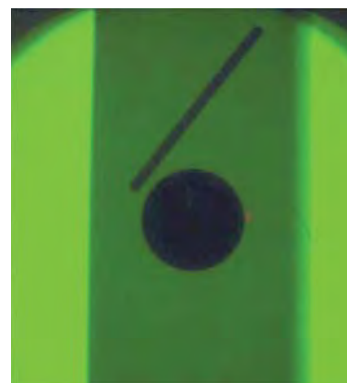

Pictures of the implant model projection in the y,z-plane.

Principle

This experiment provides training in determining the length and position of an object based on an X-ray image. A metal pin that is embedded in a wooden block is used as the model. This experiment is also an excellent preparatory exercise for demonstrating the principle of computed tomography.

Tasks

1. Record a bi-planar radiogram of two perpendicular planes of a metal pin which cannot be seen.
2. Determine the true length of the pin by taking into account the magnification factor which results from the divergence of the X-rays.
3. Determine the spatial position of the pin.

What you can learn about

- X-ray radiation
- Bremsstrahlung
- Characteristic radiation
- Law of absorption
- Mass absorption coefficient
- Stereographic projection

Main articles

XR 4.0 expert unit	09057-99	1
XR 4.0 X-ray plug-in unit W tube	09057-80	1
XR 4.0 X-ray fluorescent screen	09057-26	1
XR 4.0 X-ray optical bench	09057-18	1
XR 4.0 X-ray slide for external optical bench	09057-29	1
XR 4.0 X-ray Adapter for digital camera 1/4"	09057-15	1
XR 4.0 X-ray Implant model f.x-ray photography	09058-07	1

Best fitting X-ray sets for this experiment:

XRE 4.0 X-ray expert set

09110-88

XRI 4.0 X-ray imaging upgrade set

09150-88

XR 4.0 X-ray Implant model for X-ray photography



Function and Applications

For use with x-ray unit 35 kV to determine the length and spatial position of a non visible metal pin which is enclosed in a block of wood.

09058-07

Debye-Scherrer diffraction measurements for the examination of the texture of rolled sheets

P2542701

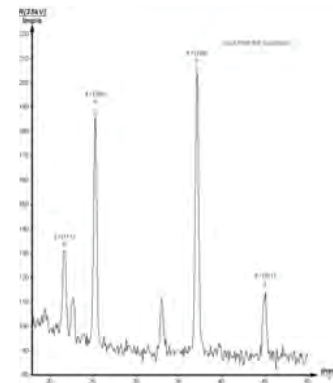

Debye-Scherrer diagram of a rolled copper sheet.

Principle

A polycrystalline, cubic face-centered crystallizing copper powder sample and a thin copper sheet are separately irradiated with the radiation from a Roentgen tube with a copper anode. A Geiger-Mueller counter tube is automatically swivelled to detect the radiation that is constructively reflected from the various lattice planes of the crystallites. The Bragg diagrams are automatically recorded. The evaluation allows the Bragg reflexes to be assigned to the individual lattice planes. In contrast to the powder sample, the rolled thin sheet gives a spectrum showing an alignment of the crystallites (rolled texture), that is made even more complete by heating the sheet.

Tasks

1. Record the intensity of the Cu X-rays back scattered by a cubic crystallizing copper powder sample as a function of the scattering angle.
2. Assign the Bragg reflexes to the individual lattice planes.
3. Record the Bragg spectrum of a thin sheet of copper.
4. Repeat the measurements made in Task 3 after the sheet of copper has been subjected to annealing.

What you can learn about

- Crystal lattices; Crystal systems; Bravais-lattice
- Reciprocal lattice; Miller indices; Structure factor
- Atomic scattering factor; Bragg scattering
- Characteristic X-rays; Monochromatization of X-rays
- Fiber textures; Sheet textures; Annealing texture
- Recrystallization

Main articles

XR 4.0 expert unit	09057-99	1
XR 4.0 X-ray goniometer	09057-10	1
XR 4.0 X-ray Plug-in Cu tube	09057-50	1
XR 4.0 Software measure X-ray	14414-61	1

Related X-ray Experiment

Counter tube characteristics

P2540010

Best fitting X-ray sets for this experiment:

XR 4.0 X-ray expert set

09110-88

XR 4.0 X-ray structural analysis upgrade set

09140-88

XR 4.0 Software measure X-ray



Function and Applications

Software package of the "measure" series for controlling the XR 4.0 expert unit (X-ray unit). XR 4.0 measure X-ray consists of a module for device control and measurement data recording and a module for measurement data processing (main program).

14414-61

4 Non-destructive Testing (NDT)

4.1 X-ray Investigations

P2545001 Quantitative X-ray fluorescence analysis of alloyed materials

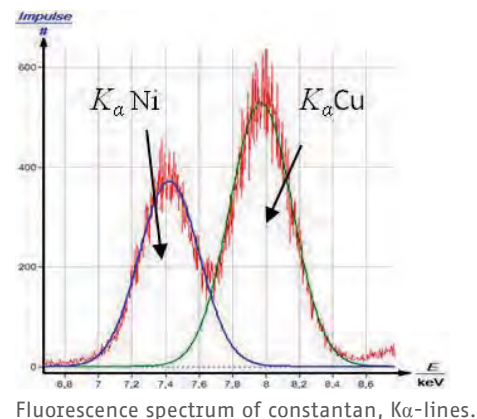

Principle

Various alloyed materials are subjected to polychromatic X-rays. The energy of the resulting fluorescence radiation is analysed with the aid of a semiconductor detector and a multichannel analyser. The energy of the corresponding characteristic X-ray fluorescence lines is determined.

In order to determine the concentration of the alloy constituents, the intensity of their respective fluorescence signals is compared to that of the pure elements.

Tasks

1. Calibration of the semiconductor energy detector with the aid of the characteristic radiation of the tungsten X-ray tube.
2. Recording of the fluorescence spectra that are produced by the alloyed samples.
3. Recording of the fluorescence spectra that are produced by the pure metals.
4. Determination of the energy values of the corresponding fluorescence lines.
5. Calculation of the concentration levels of the alloy constituents.

What you can learn about

- Bremsstrahlung
- Characteristic X-radiation
- Energy levels
- Fluorescent yield
- Auger effect
- Coherent and incoherent photon scattering
- Absorption of X-rays
- Edge absorption
- Matrix effects
- Semiconductor energy detectors
- Multi-channel analysers

Main articles

XR 4.0 expert unit	09057-99	1
XR 4.0 X-ray energy detector (XRED)	09058-30	1
XR 4.0 X-ray goniometer	09057-10	1
XR 4.0 X-ray plug-in unit W tube	09057-80	1
Multi channel analyser	13727-99	1
XR 4.0 X-ray Specimen set metals for fluorescence, set of 4	09058-34	1
XR 4.0 X-ray Specimen set metals for X-ray fluorescence, set of 7	09058-31	1

Related Experiment

Quantitative X-ray fluorescence analysis of solutions

P2545101

Best fitting X-ray sets for this experiment:

XR 4.0 X-ray expert set

09110-88

XRM 4.0 X-ray material analysis upgrade set

09160-88

X-ray fluorescence spectroscopy / layer thickness determination

P2545201

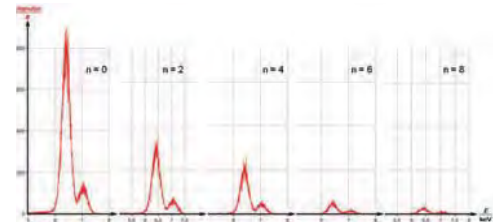

Fe-fluorescence lines as a function of the number n of the pieces of aluminium foils placed on the substrate.

Principle

X-ray fluorescence analysis (XRF) is suitable for the non-contact and non-destructive thickness measurement of thin layers as well as for determining their chemical composition. For this type of measurement, the X-ray source and detector are located on the same side of the sample. When the layer on the substrate is subjected to X-rays, the radiation will penetrate the layer, if it is sufficiently thin, to a certain extent, depending on the thickness, and in turn cause characteristic fluorescence radiation in the material of the underlying substrate. On its way to the detector, this fluorescence radiation will be attenuated by absorption at the layer. The thickness of the layer can be determined based on the intensity attenuation of the fluorescence radiation of the substrate material.

Tasks

1. Calibrate the semiconductor energy detector.
2. Measure fluorescence spectrum of the iron substrate with different numbers n of pieces of aluminium foil with the same thickness placed on the substrate (including $n = 0$). Determine the intensity of the Fe- $K\alpha$ fluorescence line.
3. Plot the intensity of the Fe- $K\alpha$ fluorescence line as a function of the number of pieces of aluminium foil placed on the substrate in linear and semilogarithmic way.
4. Determine the intensity of the Fe- $K\alpha$ fluorescence line for various numbers of pieces of aluminium foil that are fastened in front of the outlet of the tube of the energy detector.
5. Calculate the thickness of the aluminium foil.
6. Execute tasks 2 to 4 for copper foil on molybdenum or zinc substrate.

What you can learn about

- Bremsstrahlung
- Characteristic X-radiation
- Fluorescent yield
- Auger effect
- Coherent and incoherent photon scattering

- Law of absorption
- Mass attenuation coefficient
- Saturation thickness
- Matrix effects
- Semiconductor
- Energy detectors
- Multi-channel analysers

Main articles

XR 4.0 expert unit	09057-99	1
XR 4.0 X-ray energy detector (XRED)	09058-30	1
XR 4.0 X-ray goniometer	09057-10	1
XR 4.0 X-ray plug-in unit W tube	09057-80	1
Multi channel analyser	13727-99	1
XR 4.0 X-ray Specimen set metals for X-ray fluorescence, set of 7	09058-31	1
XR 4.0 X-ray Specimen set metals for fluorescence, set of 4	09058-34	1

Best fitting X-ray sets for this experiment:**XRE 4.0 X-ray expert set**

09110-88

XRM 4.0 X-ray material analysis upgrade set

09160-88

4 Non-destructive Testing (NDT)

4.1 X-ray Investigations

P2550100 Computed tomography



CT of an USB flash drive (movie).

Principle

The CT principle is demonstrated with the aid of simple objects. In the case of very simple targets, only a few images need to be taken in order to achieve a good result. The more complicated the objects are, the more images are necessary in order to show all the details. In addition, special samples are used to demonstrate how artefacts are generated and what causes beam hardening.

Tasks

1. Record a CT scan of the simple objects. While doing so, vary the number of steps.
2. Record a CT scan of the metal samples and analyse the result in view of beam hardening.

What you can learn about

- Beam hardening; Artefacts; Algorithms



EduMedia Award for Didactical Software for:



Main articles		
XRE 4.0 X-ray expert set	09110-88	1
XR 4.0 X-ray Direct Digital Image Sensor (XRIS) with USB cable	09057-40	1
XR 4.0 X-ray CT Z-rotation stage (XRstage)	09057-42	1

Best fitting X-ray sets for this experiment:	
XRE 4.0 X-ray expert set	09110-88
XRCT 4.0 X-ray Computed Tomography upgrade set	09180-88



Allan M. Cormack (left)

Sir Godfrey Newbold Hounsfield (right)

1979, Nobel Prize in Medicine

XRE 4.0 X-ray expert set

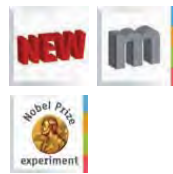

Function and Applications

Basic set covering the fundamental principles and areas of applications of X-rays, e.g. fluoroscopy experiments and X-ray photography. It can be extended by upgrade sets for specific applications and topics.

Benefits

- Safety concept complying with the applicable standards and regulations
- S-Lock - PHYWE novel safety interlock
- Design patent; Protection of utility patent; General patent pending
- Tube XChange technology
- Touch panel
- 3View - Insight provides a transparent view
- High-resolution TFT backlit display
- XXL chamber
- Optical bank with riders
- Goniometer (optional)
- MultiLINK
- Safekeeping drawer

Equipment and technical data

The set includes the following components:

- XR 4.0 expert unit
- XR 4.0 X-ray plug-in unit with a tungsten X-ray tube
- XR measure 4.0 X software
- TESS expert manual "Experiment with X-radiation"
- USB cable, mains cable with adaptor
- Optical bench with
- Quick-start guide, operating instruction
- Fluorescent screen

Recommended upgrade sets for various applications and topics

- XRW 4.0 X-ray wireless demonstration upgrade set, 09115-88
- XRP 4.0 X-ray solid state upgrade set, 09120-88
- XRC 4.0 X-ray characteristics upgrade set, 09130-88
- XRS 4.0 X-ray structural analysis upgrade set, 09140-88
- XRI 4.0 X-ray imaging upgrade set, 09150-88
- XRM 4.0 X-ray material analysis upgrade set, 09160-88
- XRD 4.0 X-ray dosimetry and radiation damage upgrade set, 09170-88
- XRCT 4.0 X-ray Computer Tomography upgrade set, 09180-88

09110-88

XRCT 4.0 X-ray Computed Tomography upgrade set

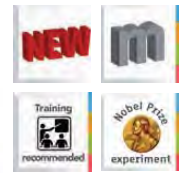

Function and Applications

Upgrade set as an extension of the XRE 4.0 expert set (09110-88). Show the fundamental principles of computed tomography (CT) with the aid of a state of the art system whose technology is currently applied in medical and industrial applications. The interfaces of this method towards medicine, materials science and engineering make the "Computed Tomography Set" particularly suitable for laboratory experiments and lectures in physics, medicine, and materials science. The set covers the following experiments and topics:

- X-ray imaging of biological and technical samples
- Non-destructive testing (NDT)
- Digital image processing for the generation of three-dimensional images of an object; Digital images of Laue patterns

Benefits

- Acquisition of the X-ray images by a direct X-ray digital image sensor: No extra fluorescent screen is necessary, experimentation under daylight conditions is possible.
- High-performance image sensors for the direct digital X-ray radiography to create superior image quality, and high resolution based on CMOS technology. Even pictures with low contrast like Laue patterns are made in less than 1 min.
- Z-axis rotation of the sample to be analysed: Movement of the sample is not influenced by gravitational effects, rigid bodies of flexible size can be analysed on a simple way.
- Acquisition of high resolution CT scan, 360° image stack within 10 minutes (one frame per second, one degree per frame).
- Protection of utility patent, registered by "Deutsches Patent- und Markenamt".

Equipment and technical data

The set includes the following components:

- XR 4.0 direct digital image sensor, 09057-41
 - Active area 5 x 5 cm²
 - Resolution 46 µm
 - Image depth 12 bit
 - USB 2.0 interface
- XR 4.0 CT object Z-rotation unit, 09057-41
 - Angle resolution < 1 degree
 - Motorised, USB 2.0 interface
 - Stepper motor with 4200 steps/360°
- Measure XR 4.0 tomography software package, 14421-61
- XR 4.0 CT accessories, 09057-42

09180-88

4 Non-destructive Testing (NDT)

4.1 X-ray Investigations

XR 4.0 X-ray Direct Digital Image Sensor (XRIS) with USB cable



Function and Applications

Digital X-ray camera to perform X-ray imaging (radiography) and X-ray Computer Tomography (CT) experiments. Particularly suitable for experiments in lab courses and lectures in physics, medical education and material sciences.

Benefits

- Direct acquisition of the X-ray images by a direct X-ray digital image sensor: Experimentation under daylight conditions
- High-performance CMOS image sensors for the direct digital X-ray radiography to create superior image quality, high resolution, and large active area images based on CMOS technology.

Equipment and technical data

- Active area 5 x 5 cm²; Resolution 48 µm; Image depth 12 bit
- USB 2.0 interface
- USB-cable

09057-40

XR 4.0 X-ray CT Z-rotation stage (XRstage)



Function and Applications

Rotating table to position samples e.g. for the CT application.

Benefits

- Z-axis rotation of the sample to be analysed: Movement of the sample is not influenced by gravitational effects, rigid bodies of flexible size can be analysed on a simple way.

Equipment and technical data

- Angle resolution < 1 degree, motorised
- Plug&measure interface, stepper motor with 4200 steps/360°

09057-42

XR 4.0 Software measure CT



Function and Applications

Software package of the "measure" series for controlling the digital X-ray sensor XRIS and the X-ray unit XR 4.0. The data can be exported in all of the established formats and then evaluated with the aid of professional software. This ensures a smooth transition from training to professional application.

Benefits

Plug & measure:

- The intuitive user concept considerably simplifies the operation of the complex devices and puts the experiment into the focus of attention. Automatic identification of the connected devices of the XR 4.0 series. Working directly without the need for specialist knowledge.

Double Control:

- Simultaneous operation via manual control or via a computer.

Reference experiments:

- The comprehensive collection of reference experiments and projects simplifies the selection of suitable experiments and can be used as a template for own experiment scripts/laboratory handbooks.

Clear structure:

- The software is clearly divided into the 4 basic steps: "Parameters", "CT scan", "Reconstruction", and "3D view". As a result, even beginners can easily familiarise themselves with the topic. Visualisation of the devices: In the first steps, numerous parameters must be set, e.g. the anode current and voltage. In order to facilitate these steps, the corresponding devices are displayed as virtual devices.

CT scan with live reconstruction:

- Sectional images are reconstructed during the scanning process. While at the beginning of the measurement hardly anything can be discerned, the contours become increasingly clear over time.

Reconstruction as an independent step: Reconstruction is the most important process step in computed tomography. Again, numerous parameters play an important role during this step. They can be changed in their own screen and their effect can be observed directly in an example image.

x,y,z-viewer and 3D view

- This area shows the results of the reconstruction process. The data can now be evaluated with professional software that the students will encounter in their future daily work. The data can be exported in all of the established formats.

Recommended System requirements:

PC with at least an Intel Core i7 2600 (3.4GHz) 8MB - 4 Cores, 8GB (2x 4GB) 1600MHz DDR3, 40GB free hard drive space, DVD-drive, 4x USB 2.0, Microsoft Windows 7 64bit or higher. Graphic card: MSI nVidia GeForce N440GT 1GB or better.

14421-61

Principles of beam intensity

P2550300

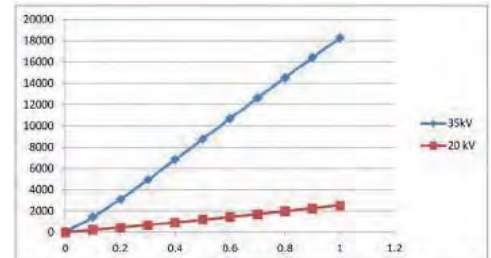

Pixel counts in function of current for different kV settings.



Principle

Laboratory based X-ray sources are in most cases polychromatic, meaning that the spectrum of the source consists of an energy range instead of a single distinctive energy peak. This has a lot of influence on the X-ray measurements that are performed. Especially the relation of the pixel count on the digital detector versus the beam power is important for optimal image quality.

Tasks

1. Determine the variation in beam intensity.
2. Investigate the inverse square law.

What you can learn about

- Beam intensity in relation to power and kV
- Inverse square law; Beam hardening
- Filtration; Spectrum; Polychromaticity
- Detector dark current

Main articles

XRCT 4.0 X-ray Computed Tomography upgrade set	09180-88	1
XRE 4.0 X-ray expert set	09110-88	1

Best fitting X-ray sets for this experiment:

XRE 4.0 X-ray expert set

09110-88

XRCT 4.0 X-ray Computed Tomography upgrade set

09180-88



4 Non-destructive Testing (NDT)

4.2 Ultrasonic Testing

P5160100 Velocity of ultrasound in solid state material

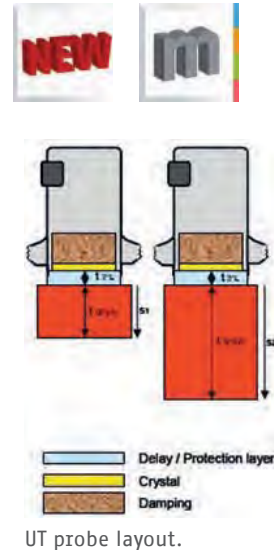
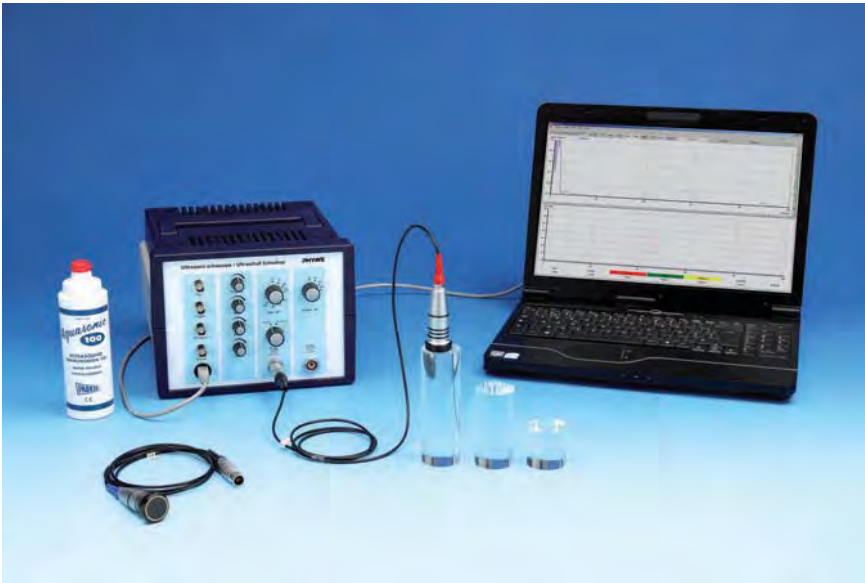

Principle

The velocity of sound in acylics shall be determined by time of flight reflection technique with an ultrasonic echoscope. The measurements are done by reflection method, on three cylinders of different length. Two measurement series are carried out with ultrasonic probes of different frequencies.

Tasks

1. Measure the length of the three cylinders with the calliper.
2. Determine the time of flight of the ultrasonic reflection pulses for the three cylinders and the two ultrasonic probes.
3. Calculate the sound velocities, probe delays and use the two mean values obtained to calculate the cylinder length.

What you can learn about

- Sound velocity
- Propagation of ultrasonic waves
- Time of flight
- Ultrasonic echography
- Thickness measurement
- Probe delay

Main articles

Basic Set Ultrasonic echoscope	13921-99	1
Vernier calliper stainless steel 0-160 mm, 1/10	03010-00	1

Basic Set Ultrasonic echoscope



Function and Applications

With the ultrasonic echoscope the basics of ultrasound and its wave characteristics can be demonstrated. Terms like amplitude, frequency, sound velocity or Time Gain Control TGC will be explained. The cylinder set can be used to vividly demonstrate reflection as well as sound velocity and frequency depending on attenuation in solid state materials.

The knowledge e.g. regarding sound velocity will be used to measure the test block.

The principles of image formation from A-scan to B-scan can be explained. With the different probes the frequency depending resolution can be evaluated.

13921-99

Ultrasonic echography (A-Scan)

P5160200

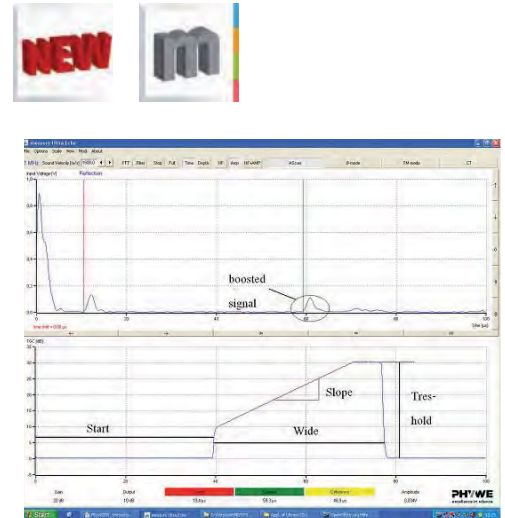
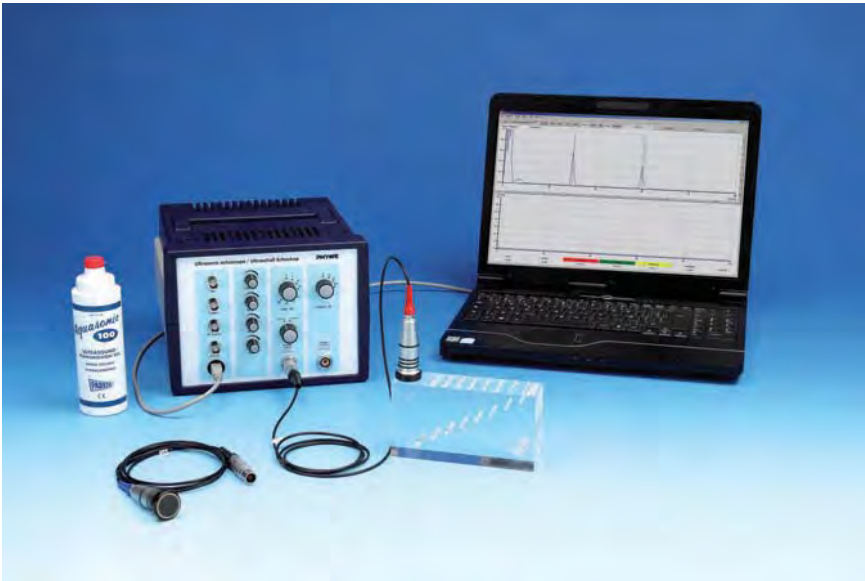

Illustration of the effects of the amplifier or booster settings on the diagram.

Principle

An ultrasonic wave transmitted in a sample will be reflected at discontinuities (defects, cracks). From the relationship between the time of flight of the reflected wave and the sound velocity, the distance between ultrasonic transducer and defects (reflector) can be calculated. Position and size of these defects can be determined by measuring in different directions.

Tasks

1. Measure the longest side of the block with the calliper and the time off light of ultrasound wave for this distance with the 2 MHz probe.
2. Calculate the sound velocity.
3. Measure the position and the size of the different defects of the test block with the calliper and the ultrasound echography method.

What you can learn about

- Propagation of ultrasonic waves
- Time of flight; Echo amplitude
- Reflection coefficient
- A-scan
- Flaw detection
- Non destructive testing (NDT)
- Ultrasonic transceiver

Main articles

Basic Set Ultrasonic echoscope	13921-99	1
--------------------------------	----------	---

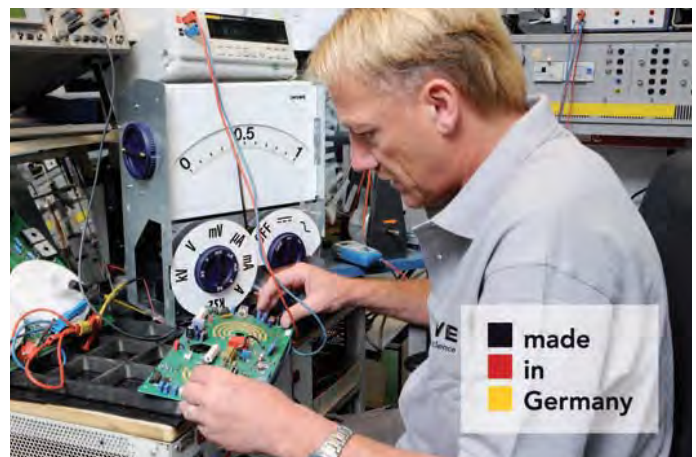

4 Non-destructive Testing (NDT)

4.2 Ultrasonic Testing

P5160300 Ultrasonic echography (B-Scan)



B-Scan image produced with the 2MHz probe.

Principle

The fundamental principles concerning the generation of ultrasonic B-scan images (brightness representation of the reflection amplitudes) are demonstrated with the aid of a simple test object. The experiment is executed with an ultrasonic echoscope in the pulse-echo-mode and the object is scanned manually. Then, the image quality and the most important image defects will be assessed.

Tasks

1. Measure the 3 edge lengths of the test block with a vernier calliper and determine the time of flight of the sound for the various edge lengths of the test block with the aid of the measurement software.
2. Calculate the sound velocity of the test block material and switch the measurement software (A-scan mode) to depth measurement.
3. Produce two B-scans, one with the 1 MHz probe and one with the 2 MHz probe, with the aid of the measurement software (B-scan mode).
4. Measure the depth and width of the echoes in the resulting images.
5. Characterise the quality of the images in terms of their resolution and defects.

What you can learn about

- Sound velocity; Reflection coefficient
- Ultrasonic echography
- A-scan; B-scan; Greyscale display
- Resolution; Zone of focus
- Image artefacts

Main articles

Basic Set Ultrasonic echoscope 13921-99 1



Angle beam measurement

P5160400

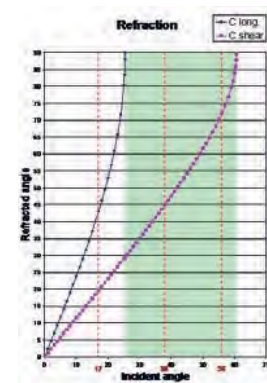
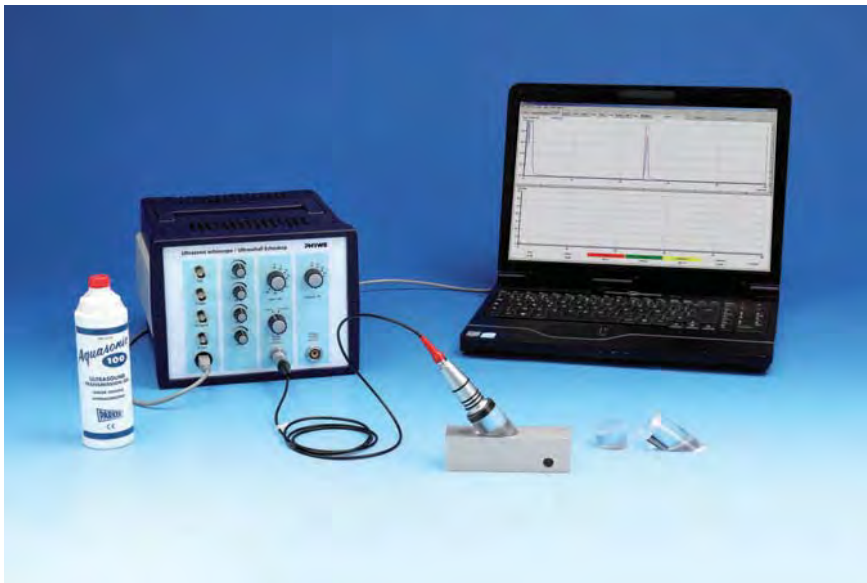

Direction of propagation of a shear wave and a longitudinal wave from a plexiglass delay line into an aluminium test object as a function of the beam entry angle.

Principle

The experiment demonstrates the application of ultrasonic angle beam probes in non-destructive testing. Echoes of transverse and longitudinal waves coming from an aluminium testblock are investigated using three different delay line angles.

For straight beam probes, the distance is calculated using simply the time of flight and the sound velocity of longitudinal wave. Angle beam probes require in addition the length of the delay line, the sound velocity of the transverse wave, the angle of the probe and the sound exit point of the delay line. The probe calibration is checked measuring half and full skip distance on a cylindrical discontinuity.

Tasks

1. Examine with three different angle delay lines, the half and full skip distance in an aluminium alloy bloc. Determine which probes allow to measure longitudinal and transverse wave echoes.
2. Measure first with the 38° and then with the 17° angle delay line, the time of flight and the positions of the probe at half and full skip distance.
3. Calculate the sound exit point, the incidence angle, the acoustic path, the sound velocity and the length of the delay line.
4. Check the probe characteristics on a cylindrical discontinuity. Measure the depth and the projected distance of the flaw in the test block and compare these values with the sketch.

What you can learn about

- Angle beam probe; Incident angle; Ultrasonic refraction; Longitudinal wave
- Shear wave; Angle beam echo; Skip distance; Ultrasound echography; A-mode; Reflection

Main articles

Basic Set Ultrasonic echoscope	13921-99	1
Extension set: Non destructive testing	13921-01	1
Vernier calliper stainless steel 0-160 mm, 1/10	03010-00	1

Extension set: Non destructive testing**Function and Application**

Studies of ultrasound techniques used in NDT applications:

- Flaw detection
- Angle beam inspection
- Time of flight diffraction (TOFD)

Particular suitable for NDT training

Benefits

Different NDT techniques can be demonstrated with the same equipment. No special unit for TOFD required.

13921-01

4 Non-destructive Testing (NDT)

4.2 Ultrasonic Testing

P5160500 Time of flight diffraction (TOFD)

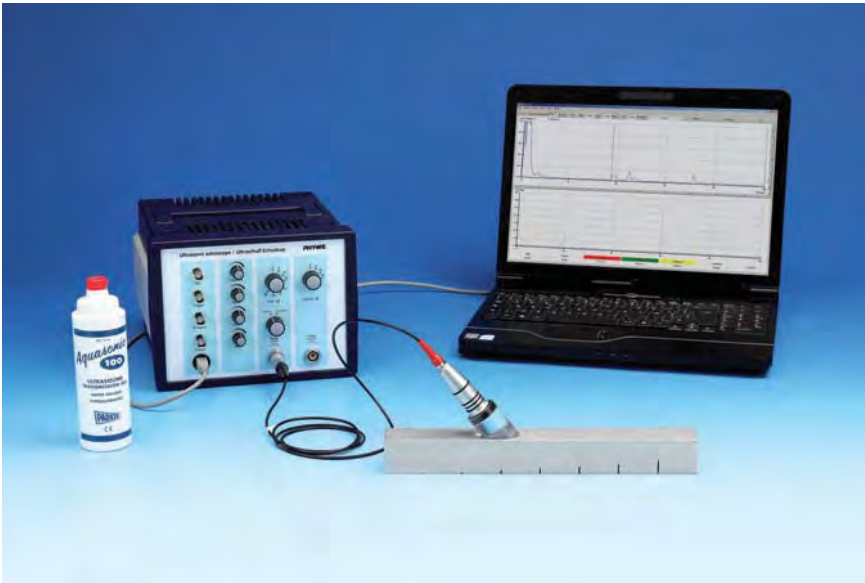

Reflection of an ultrasound beam at a small crack (left) and at a deep crack (right).

Principle

The depth of the cracks of an aluminium test block with seven cracks of different depths (saw cuts) is determined with two methods. During the experiment, the cracks in the material are examined with the aid of the ultrasound angle beam probe and the depth of the cracks is determined with the aid of the signal amplitude and the TOFD method (time of flight diffraction). Both methods are compared based on their measurement results and in view of their performance and detection limits. The test block is scanned in accordance with the TOFD method as well as with a special probe combination so that the corresponding scan image of the crack distribution can be generated.

Tasks

1. Determine the sound velocity of the shear wave in a test block for the crack depth determination with the angle beam probe based on the corner echoes at half and full skip distance.
2. Prepare a characteristic groove curve for the cracks of the aluminium test block for determining the crack depth based on the echo amplitude.
3. Determine the crack depths of the test block with the TOFD method and compare the results to the results of the echo amplitude method.
4. Scan the test object with a TOFD scanning head and analyse the cracks in the TOFD scan.

What you can learn about

- Non-destructive testing (NDT)
- TOFD method (time of flight diffraction)
- Ultrasonic diffraction
- Sound velocity
- Shear waves (transverse waves)
- Corner echo
- B-scan
- Preferential corrosion measurement

Main articles

Basic Set Ultrasonic echoscope	13921-99	1
Extension set: Non destructive testing	13921-01	1
Ultrasonic probe 2 MHz	13921-05	1
Vernier calliper stainless steel 0-160 mm, 1/10	03010-00	1
Ruler, plastic, 200 mm	09937-01	1

Ultrasonic probe 2 MHz



Function and Applications

The 2 MHz probes are suitable for largerange use. Due to the higher frequency the axial and lateral resolution is better compared to the 1 MHz probes. On the other hand the damping of 2 MHz sound waves in most materials is not too large, so that they can be used for medium range investigations. The 2 MHz probes are suitable for measurements at medical objects and as ultrasound Doppler-probes.

13921-05

Detection of discontinuities

P5160600

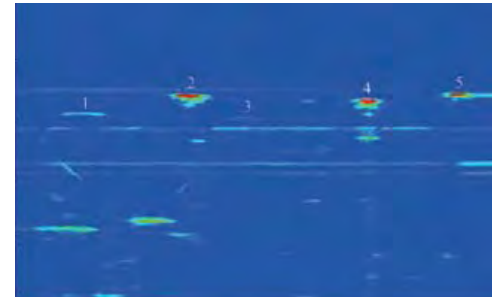
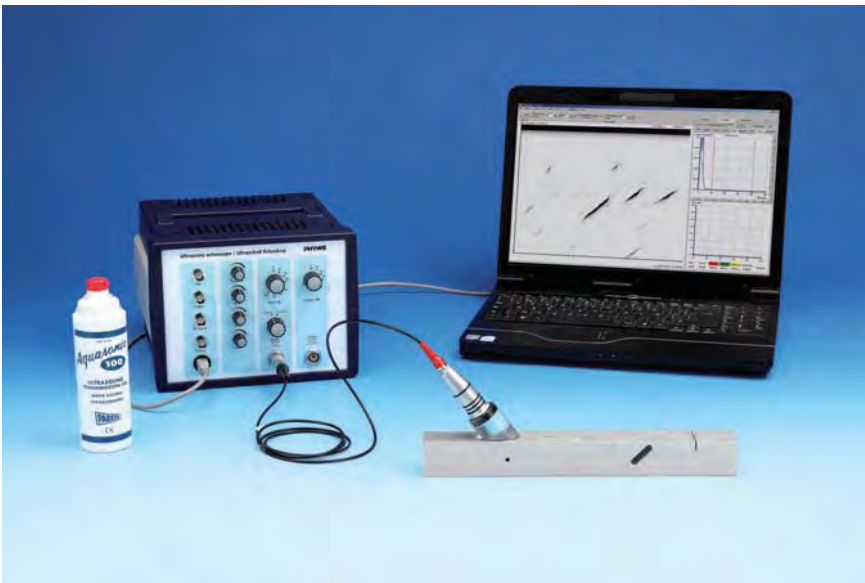

Sectional image of the test object with the TR probe.

Principle

The experiment demonstrates the application and performance of various non-destructive test methods with the aid of ultrasound. A test object with different types of discontinuities is used to perform various detection methods.

First, the test object is scanned in order to determine which detection method is suitable for which type of defect.

Then, the signal-to-noise-ratio is determined for each discontinuity with a straight beam probe, angle beam probe, and a transmitter-receiver probe (TR probe). This is followed by a discussion of the results in view of the selection of the most suitable detection method for a specific task.

Tasks

1. Use a 2 MHz straight beam probe (vertical scanning direction) to define the suitable device parameters at the ultrasonic echoscope. Produce a B-scan of the test object.
2. Assign the various defects (discontinuities) of the test object to the B-scan. Then, determine the signal-to-noise-ratio for each discontinuity in the A-mode.
3. Repeat the above-mentioned tests/measurements on the same test object with an angle beam probe and then with a TR probe (transmitter-receiver probe).
4. Assess and represent the detectability of the discontinuities with the respective test methods.

What you can learn about

- Ultrasonic echography
- Discontinuity
- A-Mode
- Straight beam probe
- Angle beam probe
- Reflection
- Beam angle
- Signal-to-noise ratio

Main articles

Basic Set Ultrasonic echoscope	13921-99	1
Extension set: Non destructive testing	13921-01	1
Vernier calliper stainless steel 0-160 mm, 1/10	03010-00	1
Ruler, plastic, 200 mm	09937-01	1

Vernier calliper stainless steel 0-160 mm, 1/10**Function and Applications**

Sliding caliper for exterior, interior and depth measurements, with instant fixing device. Made of hardened stainless steel.

Equipment and technical data

- Subdivision mm and inch
- Vernier 1/10
- Measuring range: 0...160 mm
- With storage pouch

03010-00

4 Non-destructive Testing (NDT)

4.2 Ultrasonic Testing

P5160700 Frequency dependence of resolution power

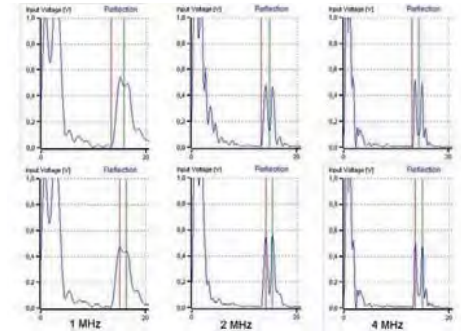

Illustration of the ultraechos, reflected at the two holes, close to each other.

Principle

The different axial resolution power of a 1 MHz, a 2 MHz and a 4 MHz ultrasonic probe is examined on two close defects. The relationship between cycle time, sound velocity, frequency, wave length, pulse length and resolution power is illustrated in this experiment.

Tasks

1. Measure the block in the three dimensions using the caliper.
2. Record the echo of the background in these directions and calculate the sound velocity.
3. Measure the period of the ultrasonic wave on the different ultrasonic probes. Calculate the frequency. Based on the sound velocity, calculate the wave length.
4. Measure the width of an ultrasonic alternation (half-wave). Measure the width of a wave at 50 % of the maximum elongation (maximum of the sinus curve). The result is called the pulse-width. Repeat it for the other probes.
5. Measure the time of flight to the holes 1 and 2 (i.e. the two small holes right next to each other) with every single probe. Take two readings, one at the beginning of the echo, and the other one at its maximum. Based on these two figures, calculate the distance between the two holes and compare the results.

What you can learn about

- Ultrasonic waves; Frequency; Sound velocity
- Wave length; Axial and lateral resolution
- Ultrasonic echography (A-Scan); Ultrasonic imaging (B-Scan)

Main articles

Basic Set Ultrasonic echoscope	13921-99	1
Ultrasonic probe 4 MHz	13921-02	1

Vernier calliper stainless steel 0-160 mm,
1/10

03010-00 1

Ultrasonic probe 4 MHz

Function and Applications

The 4 MHz probe is distinguished by an extreme short drive level dependence which results in the high axial resolution power. This probe is used for detection of very small structures, mainly for investigations in liquids, where the limited penetration depth is no problem. The high resolution power and the related spectral bandwidth make this probe particularly suitable for investigations on thin plates and for ultrasound computer tomography.

Benefits

- The ultrasonic probes are designed to produce high sound intensities and short sound pulses. It makes them particularly suitable for pulse-echo mode.
- All probes are sealed in a robust metal housing and are water proof at the sensor surface.
- The probes are delivered with a special plug for automatic probe recognition.

Equipment and technical data

- Sound impedance adaptation to water/acrylic
- Size: L = 70 mm, D = 27 mm
- Cable length: 1 m
- Frequency: 4 MHz

13921-02

Attenuation of ultrasound in solid state materials

P5160800

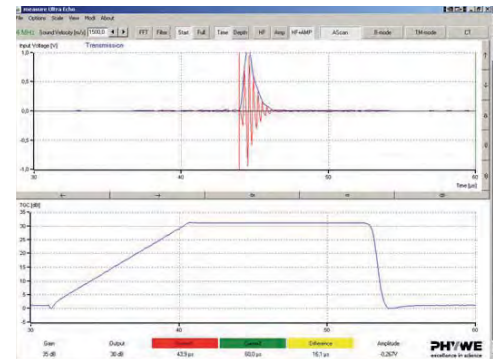
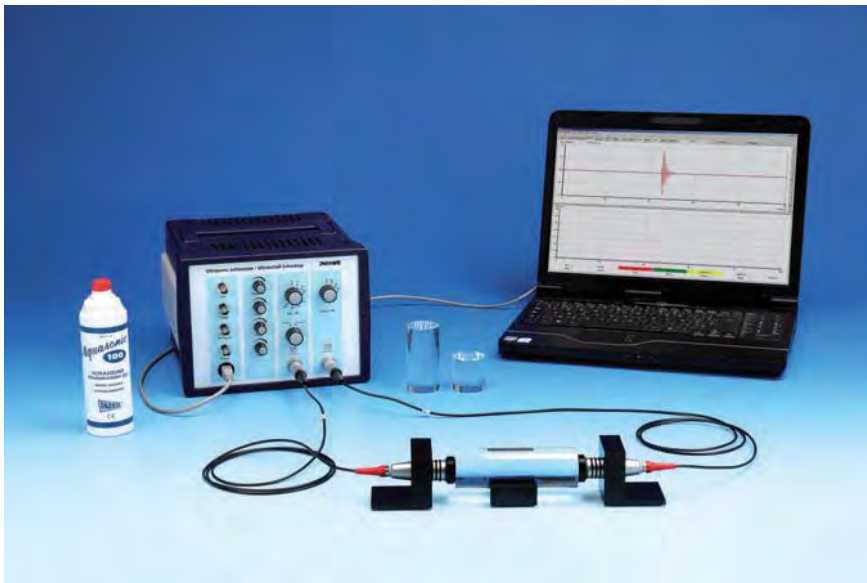

4 MHz probes, cylinder with approx. 120 mm, time-of-flight measurement with zoom on.

Principle

The damping of ultrasound in solid objects is determined for 2 (or optionally 3) different frequencies in the transmission mode. The resulting values are then compared to the corresponding literature values. In addition, the frequency dependence of the damping effect is analysed. Furthermore, the sound velocity in acrylic objects is determined for 2 (or optionally 3) different frequencies in the transmission mode.

Tasks

1. Measure the lengths of the three cylinders with the calliper.
2. Determine the amplitudes and times of flight of the ultrasonic transmission pulses for the three cylinders and the two (or three) ultrasonic probes.
3. Calculate the attenuation and sound velocity values.

What you can learn about

- Propagation of ultrasonic waves
- Time of flight
- Sound velocity
- Damping of ultrasonic waves (scattering, reflection, absorption)
- Transmission coefficient

Main articles

Basic Set Ultrasonic echoscope	13921-99	1
Extension set: Shear waves	13921-03	1
Ultrasonic probe 2 MHz	13921-05	1
Vernier calliper, plastic	03011-00	1

Extension set: Shear waves



Function and Applications

When an ultrasonic wave hits a solid state material in a certain angle, shear waves will be generated with increasing angle. Shear waves have a sound velocity differing to that of longitudinal waves. With this experimental equipment the transition from longitudinal to shear waves can be measured angle-dependently.

Benefits

Basics of ultrasounds which can not been demonstrated with industrial equipment are shown in an very didactical manner.

Equipment and technical data

- 1x Ultrasonic probe 1 MHz
- 1x Shear wave set (incl. 2 probe holders)
- 1x Aluminium sample for shear waves
- 1x Hydrophone for sound field measurement
- 1x Hydrophone plate
- 1x Hydrophone holder
- 1x Holder block

13921-03

4 Non-destructive Testing (NDT)

4.2 Ultrasonic Testing

P5160900 Shear waves in solid state materials

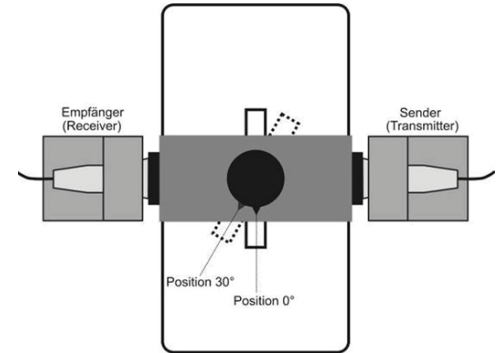
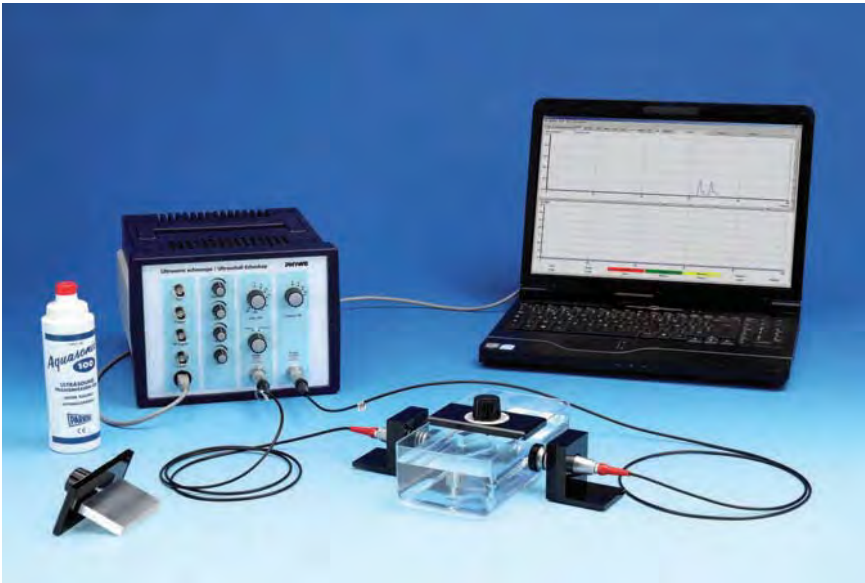

Schematic set-up with an indication of the angular positions.

Principle

The aim of this experiment is to study the generation and propagation of ultrasound waves in solid objects. In addition, the additional generation of transverse wave modes (shear wave modes) resulting from an oblique angle of incidence should be identified and the sound velocities for the longitudinal and transverse component should be determined. The relationship between the coefficients of elasticity of the material and its sound velocities enables the determination of the magnitude of the coefficients.

Tasks

1. Determine the sound amplitude of an ultrasound wave passing through an acrylic glass plate (transmission measurement) as a function of the angle of incidence for the longitudinal and transverse component.
2. Use the measurement curves to determine the longitudinal sound velocity in acrylic glass based on the angle of the total reflection, and the transverse sound velocity based on the amplitude maximums and the angle of the total reflection.
3. Determine the sound amplitude of an ultrasound wave passing through an aluminium plate (transmission measurement) as a function of the angle of incidence for the longitudinal and transverse component.
4. Use the measurement curves to determine the longitudinal sound velocity in aluminium, based on the angle of the total reflection, and the transverse sound velocity based on the angle of the amplitude maximums and the angle of the total reflection.
5. Based on the transverse and longitudinal sound velocities, calculate the coefficient of elasticity for acrylic glass and aluminium.

What you can learn about

- Ultrasonic transmission measurement
- Propagation of ultrasound waves
- Ultrasound wave modes

- Shear waves
- Longitudinal and transverse waves
- Modulus of elasticity
- Sound velocity

Main articles

Basic Set Ultrasonic echoscope	13921-99	1
Extension set: Shear waves	13921-03	1
Vernier calliper stainless steel 0-160 mm, 1/10	03010-00	1
Ruler, plastic, 200 mm	09937-01	1

You need more information?
Just click www.phywe.com

WEB@ PHYWE



Determination of the focus zone

P5161000

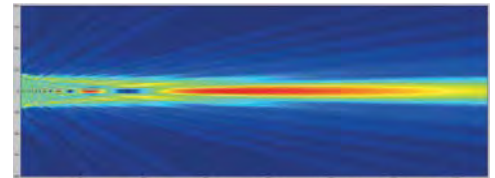
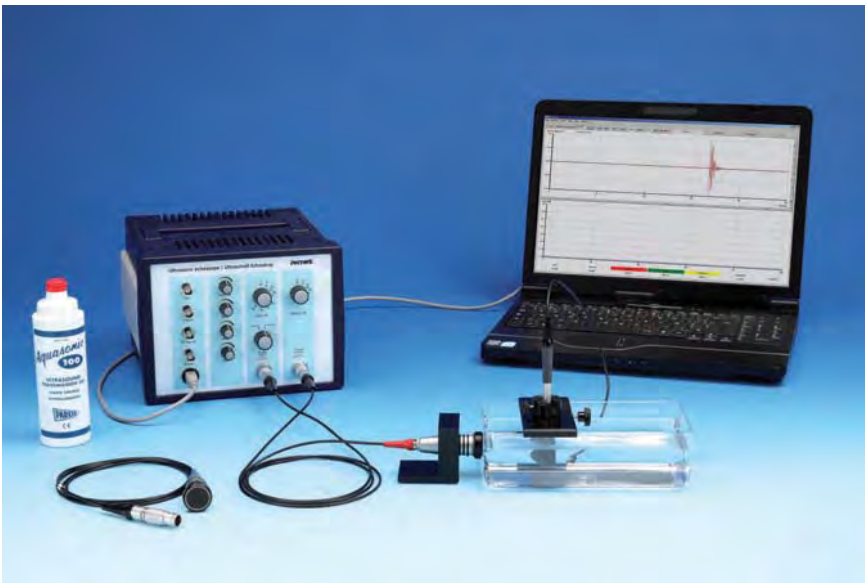

Sound field of a 2-MHz-probe with a diameter of 16 mm.

Principle

For the characterisation of round ultrasonic probes (piston-type transducers), the near-field length is an important quantity. It forms the zone of focus of an ultrasonic probe, in which the lateral resolving power has a maximum.

In this experiment, the sound pressure amplitudes of two ultrasonic probes are measured along the sound propagation axis with the aid of a simple ultrasonic hydrophone. The resulting measurement curves are then used to determine the near-field length of the ultrasonic probes, and these values are compared to the calculated probe values.

Tasks

1. Measure the relative sound pressure distribution along the acoustic axis for a 1-MHz-probe and for a 2-MHz-probe.
2. Determine the zone of focus for each of the probes with the aid of the resulting measurement curves.
3. Calculate the near-field lengths of the two probes and compare them to the corresponding values concerning the zones of focus resulting from the measurement curves.

What you can learn about

- Sound velocity; Wavelength; Huygens principle
- Interference; Near field; Far field
- Zone of focus; Near-field length; Hydrophone

Main articles

Basic Set Ultrasonic echoscope	13921-99	1
Extension set: Shear waves	13921-03	1
Ultrasonic probe 4 MHz	13921-02	1
Vernier calliper stainless steel 0-160 mm, 1/10	03010-00	1
Ruler, plastic, 200 mm	09937-01	1



4 Non-destructive Testing (NDT)

4.2 Ultrasonic Testing

P5161100 Mechanical scan methods

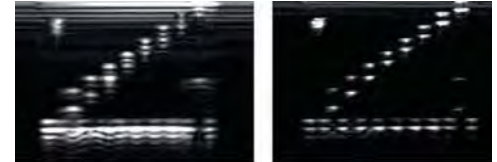
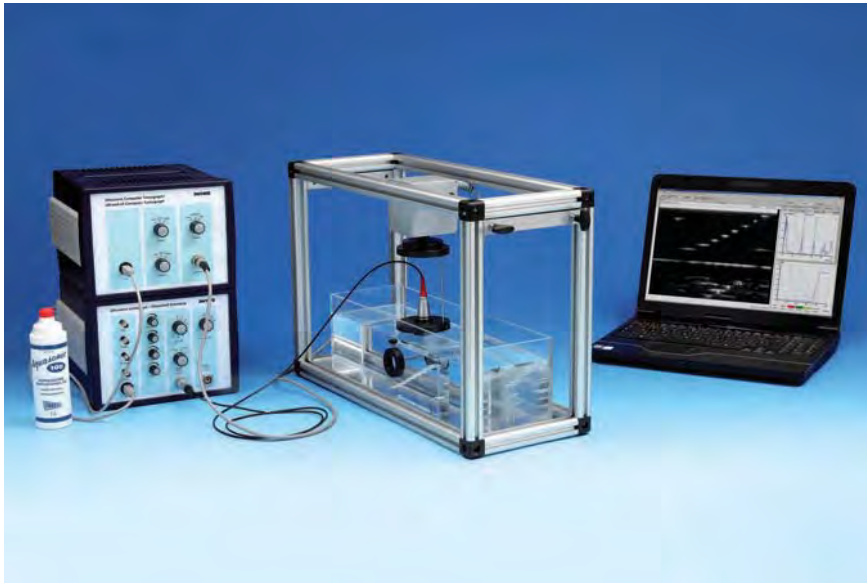

Comparison of the B-scan of the test block measured with a 1 MHz transducer (left) and then with a 2 MHz transducer (right).

Principle

The fundamental principles concerning the generation of ultrasonic B-scans (brightness scans) are demonstrated with the aid of a simple test object. The image quality characteristics, such as the zone of focus, resolving power, and artefacts, are explained.

Tasks

1. Determine the sound velocity of water and acrylic glass with the aid of the B-scan and the known dimensions of the test block.
2. Study any artefacts that occur.
3. Compare the resolution and zone of focus of 1 MHz and 2 MHz ultrasonic transducers.

What you can learn about

- Ultrasonic echography (A-scan)
- B-mode
- Resolution
- Artefacts
- Interface
- Mechanical scanner

Main articles

Basic Set Ultrasonic echoscope	13921-99	1
Extension Set: CT Scanner	13922-99	1
Vernier calliper stainless steel 0-160 mm, 1/10	03010-00	1
Ruler, plastic, 200 mm	09937-01	1



Ultrasonic computertomography

P5161200

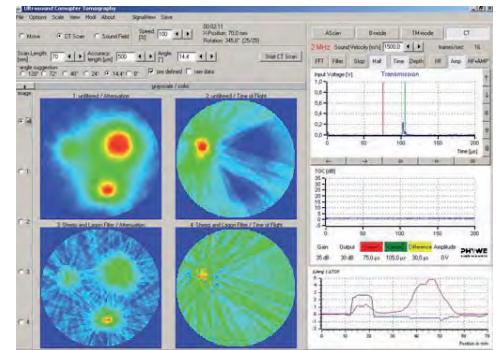

Input of the CT-scan parameters.

Principle

This experiment explains the fundamental principles of the image formation with a CT algorithm. A simple test object is used to create an attenuation tomogram and a time-of-flight tomogram followed by a discussion of the respective differences.

Tasks

1. Creation of several attenuation and time-of-flight tomograms.
2. Variation of the device parameters.
3. Discussion of the differences.

What you can learn about

- Ultrasonic echography (A-scan)
- Tomography
- Resolution

Main articles

Basic Set Ultrasonic echoscope	13921-99	1
Extension Set: CT Scanner	13922-99	1
Ultrasonic probe 2 MHz	13921-05	1

Training recommended **Service** PHYWE

For this experiment we recommend a seminar on equipment technology, handling and information of equipment-specific characteristics on site.

03333-02

Extension Set: CT Scanner



Function and Applications

This set is an extension to the ultrasonic pulse echo methods, including automated imaging methods like CT and B mode. With this set the development of a CT image can be demonstrated step by step. Automated B-scan images can be made with this set as well. The scanned objects can be measured and evaluated in axial and lateral direction. The results of the automated measurements with scanner have a much better quality, especially with the imaging methods.

Benefits

For a rather low invest, compared to real life systems, the advantages of mechanical scanning can be demonstrated in a very comprehensible way.

Equipment and technical data

- 1x CT scanner
- 1x CT control unit with tomography software
- 1x Water tank
- 1x CT sample

13922-99

P2538000 Basic methods in imaging of micro and nanostructures with atomic force microscopy (AFM)

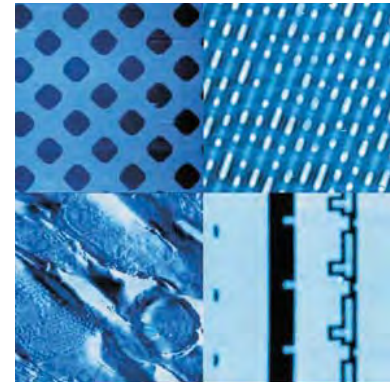

Topography of microstructure (50 μm), CD stamper (20 μm), skin cross-section (60 μm), and SCA chip structure (40 μm) FLTR.

Principle

Approaching a sharp silicon tip mounted on a cantilever to a sample surface leads to an atomic scale interaction. The result is a bend of the cantilever which is detected by a Laser. In static mode the resulting deflection is used to investigate the topography of the sample surface line-by-line using a feedback loop. In dynamic mode the cantilever is oscillated at fixed frequency resulting in a damped amplitude near the surface. The measurement parameters (setpoint, feedback gain,...) play a crucial role for image quality. The dependence on the imaging quality is investigated for different nano structured samples.

Tasks

1. Set-up the microscope and start up the software. Mount a cantilever (with tip) and approach the tip towards a sample.
2. Investigate the influence of the scanning parameters on the imaging quality and performance, e.g. PID gain, setpoint (force), vibrational amplitude, and scanning speed. Use both static and dynamic force mode.
3. Image 7 different samples (microstructures, carbon nano tubes, skin cross-section, bacteria, CD stamper, chip structure, glass beads) by optimizing the parameters respectively.

What you can learn about

- Atomic Force Microscopy (AFM)
- Lennard-Jones potential
- Imaging of nano structures
- Static Force Mode; Dynamic Force Mode
- Feedback loop; Force
- Vibrational amplitude

Main articles

Compact-Atomic Force Microscope (AFM) 09700-99 1

Related Experiments

Basic methods in force spectroscopy to investigate material characteristics with atomic force microscopy (AFM)

P2538100

Using the phase contrast mode to distinguish between different materials on the nano scale - Material contrast with AFM

P2538200

Investigate in magnetic micro and nanostructures by MagneticForce Microscopy (MFM)

P2538500

Training recommended **Service** | PHYWE

For this experiment we recommend a seminar on equipment technology, handling and information of equipment-specific characteristics on site.

03333-02

Investigate in surface atomic structures and defects of different samples by STM

P2532500

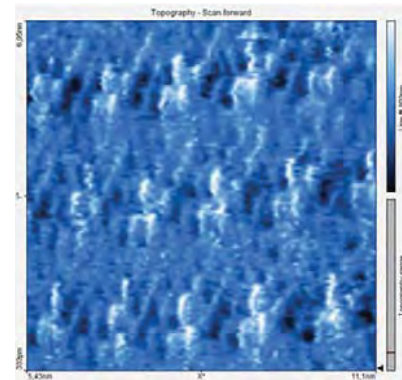

Atomic resolution on TaS2.

Principle

Scanning tunneling microscopy is used to image the (electronic) topography of different samples on a nanoscopic scale. By scanning across the surface and using analyse tools atomic arrangements, charge density waves and defects are measured and evaluated. Two dimensional fourier transformation and fourier filtering are demonstrated as a powerful tool to interpret periodic structures and visualise hidden structures.

Tasks

1. Preparation of Pt/Ir tunneling tips and different sample surfaces. Approaching the tip towards the sample.
2. Investigating the topography of clean terraces and step edges.
3. Imaging and characterisation of atomic structures and charge density waves.
4. Using two dimensional fourier transformation to determine the reciprocal lattice of periodic surface atomic arrangements and compare the k-Space (reciprocal lattice) with the real space.
5. Analysing surface structures by fourier filtering and inverse fourier transformation.

What you can learn about

- Tunneling effect
- Scanning Tunneling Microscopy (STM)
- Local Density of States
- Atomic structures and arrangements
- Charge density waves; Reciprocal lattice
- Brillouin zone; k-Space; Step edges
- Point defects; Periodic structures
- 2D Fourier Transformation (FFT)
- Fourier filtering; Inverse Fourier transformation
- Autocorrelation

Main articles

Compact-Scanning Tunneling Microscope (STM)	09600-99	1
TaS2 on sample support, for STM	09612-00	1
MoS2 on sample support, natural, for Compact Scanning Tunneling Microscope	09608-00	1
WSe2 on sample support, for STM	09610-00	1

Related Experiment

Roughness and nanomorphology of different metal samples using by STM

P2537000

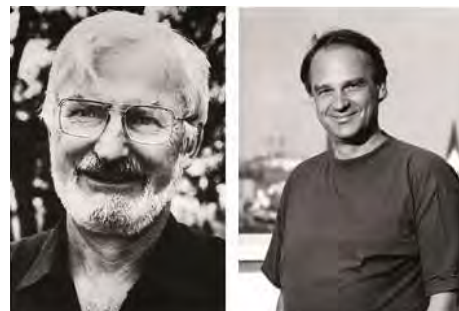

Heinrich Rohrer (left) and Gerd Binnig (right)
1986, Nobel Prize in Physics

P2150501 Chladni figures

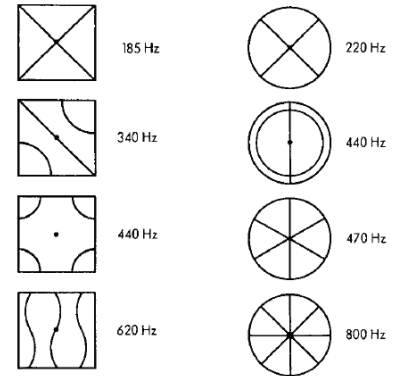
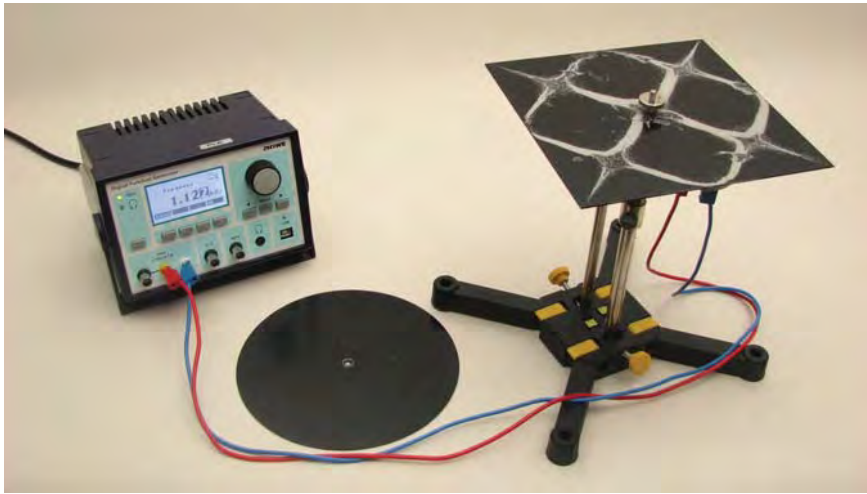

Some Chladni figures with corresponding frequencies.

Principle

Square and round metal plates are brought to vibrate through acoustic stimulations by a loudspeaker. When the driving frequency corresponds to a given Eigen-frequency (natural vibration mode) of the plate, the nodal lines are made visible with sand.

The sand is expelled from the vibrating regions of the plate and gathers in the lines because these are the only places where the amplitude of vibrations is close to zero.

Task

Determine the frequencies at which resonance occurs and drive the plate specifically at these frequencies.

What you can learn about

- Wave length
- Stationary waves
- Acoustic vibrations
- Two-dimensional standing waves
- Eigen-modes

Main articles

Digital Function Generator, USB, incl. Cobra4 Software	13654-99	1
Loudspeaker/Sound head	03524-00	1
Sound pattern plates	03478-00	1
Support base variable	02001-00	1
Sea sand, purified 1000 g	30220-67	1
Stand tube	02060-00	1
Boss head	02043-00	1

Digital Function Generator, USB, incl. Cobra4 Software



Function and Applications

Digital signal generator for use as a programmable voltage source in practical or demonstration experiments, particularly in the disciplines of acoustics, electrical engineering and electronics.

Benefits

- Can be used as universal stand-alone device or controlled via a USB interface
- Universally applicable thanks to broad, continually adjustable frequency range
- Usable as programmable voltage source via amplifier output
- Intuitive, menu-driven operation using control knob and function buttons, with help capability
- Illuminated monochrome graphic display for maximum visibility and readability

13654-99

Michelson interferometer - High Resolution

P2220900

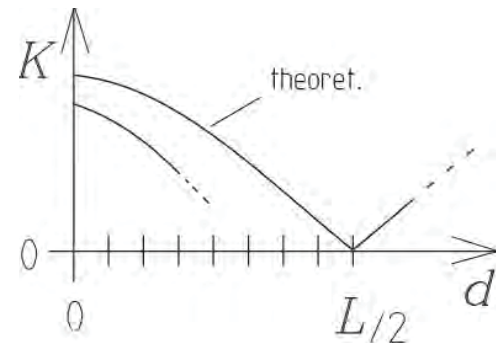
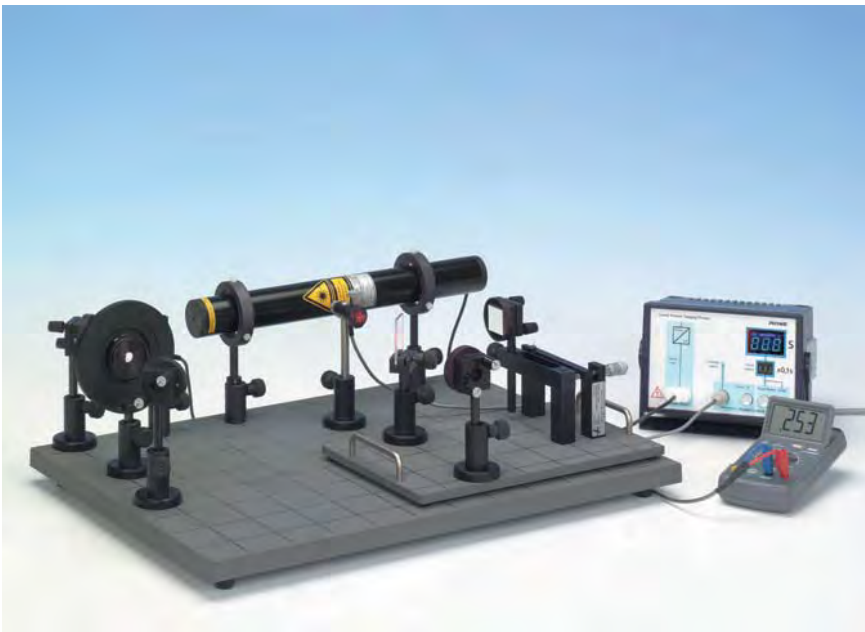

Experimentally determined contrast function in comparison to the theoretical contrast function K of a 2-mode laser.

Principle

With the aid of two mirrors in a Michelson arrangement, light is brought to interference. While moving one of the mirrors, the alteration in the interference pattern is observed and the wave length of the laser light determined.

Tasks

1. Construction of a Michelson interferometer using separate components.
2. The interferometer is used to determine the wavelength of the laserlight.
3. The contrast function K is qualitatively recorded in order to determine the coherence length with it.

What you can learn about

- Interference
- Wavelength
- Diffraction index
- Speed of light
- Phase
- Virtual light source

Main articles

He/Ne Laser, 5mW with holder	08701-00	1
Power supply for laser head 5 mW	08702-93	1
Interferometerplate w prec.drive	08715-00	1
Optical base plate with rubberfeet	08700-00	1
Photoelement f. opt. base plt.	08734-00	1
Adjusting support 35 x 35 mm	08711-00	4
Surface mirror 30 x 30 mm	08711-01	4

He/Ne Laser, 5mW with holder



Function and Applications

He/Ne laser with fixed connection cable with HV jack for laser power pack.

Equipment and technical data

- Wave length 632.8 nm
- Modes TEM₀₀
- Degree of polarisation 1:500
- Beam diameter 0.81 mm
- Beam divergence 1 mrad
- Max. power drift max. 2.5%/ 8 h
- Service life ca. 15000 h
- Coaxial cylinder casing $\varnothing = 44.2$ mm, $l = 400$ mm
- Incl. 2 holders with three-point bearing and 2 setting collars

08701-00

4 Non-destructive Testing (NDT)

4.3 Other Methods of NDT

P2260305 Transfer hologram from a master hologram

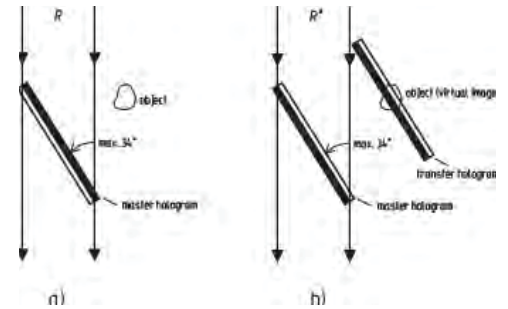

Correct selection of the object position so that the image-capture of a transfer hologram is possible.

Principle

In contrast to normal photography a hologram can store information about the three-dimensionality of an object. To capture the three-dimensionality of an object, the film stores not only the amplitude but also the phase of the light rays. To achieve this, a coherent light beam (laser light) is split into an object and a reference beam by being passed through a beam splitter. These beams interfere in the plane of the holographic film. The hologram is reconstructed with the reference beam which was also used to record the hologram.

Tasks

1. Capture the holographic image of an object.
2. Perform the development and bleaching of this phase hologram.
3. Reconstruct the transmission hologram (reconstruction beam is the reference beam during image capture).

What you can learn about

- Object beam; Reference beam; Real and virtual image
- Phase holograms; Amplitude holograms; Interference
- Diffraction; Coherence; Developing of film

Main articles

He/Ne Laser, 5mW with holder	08701-00	1
Power supply for laser head 5 mW	08702-93	1
Optical base plate in exp.case	08700-01	1
Surface mirror,large, d=80 mm	08712-00	1
Holographic plates, 25 pieces	08746-00	1
Sliding device, horizontal	08713-00	1
Darkroom equipment for holography, 230 V	08747-88	1

Power supply for laser head 5 mW

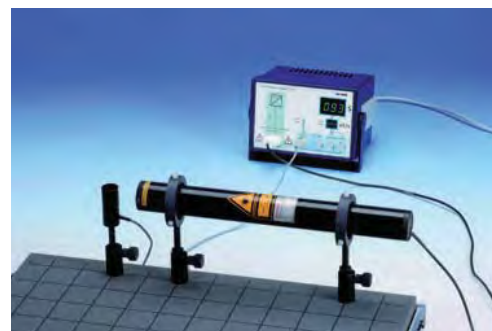

Function and Applications

High voltage power supply for lasers, e. g. the 5 mW laser (08701-00).

Equipment and technical data

- With programmable timer for selection of exposure time of holograms between 0.1 ... 99 s.
- With a controllable shutter.
- Digital display for preset shutter times as well as those which have already occurred.
- Shutter control via time select, new start, stop and shutter open (permanent open).
- Dimensions of plastic housing (mm): 184 x 140 x 130

08702-93

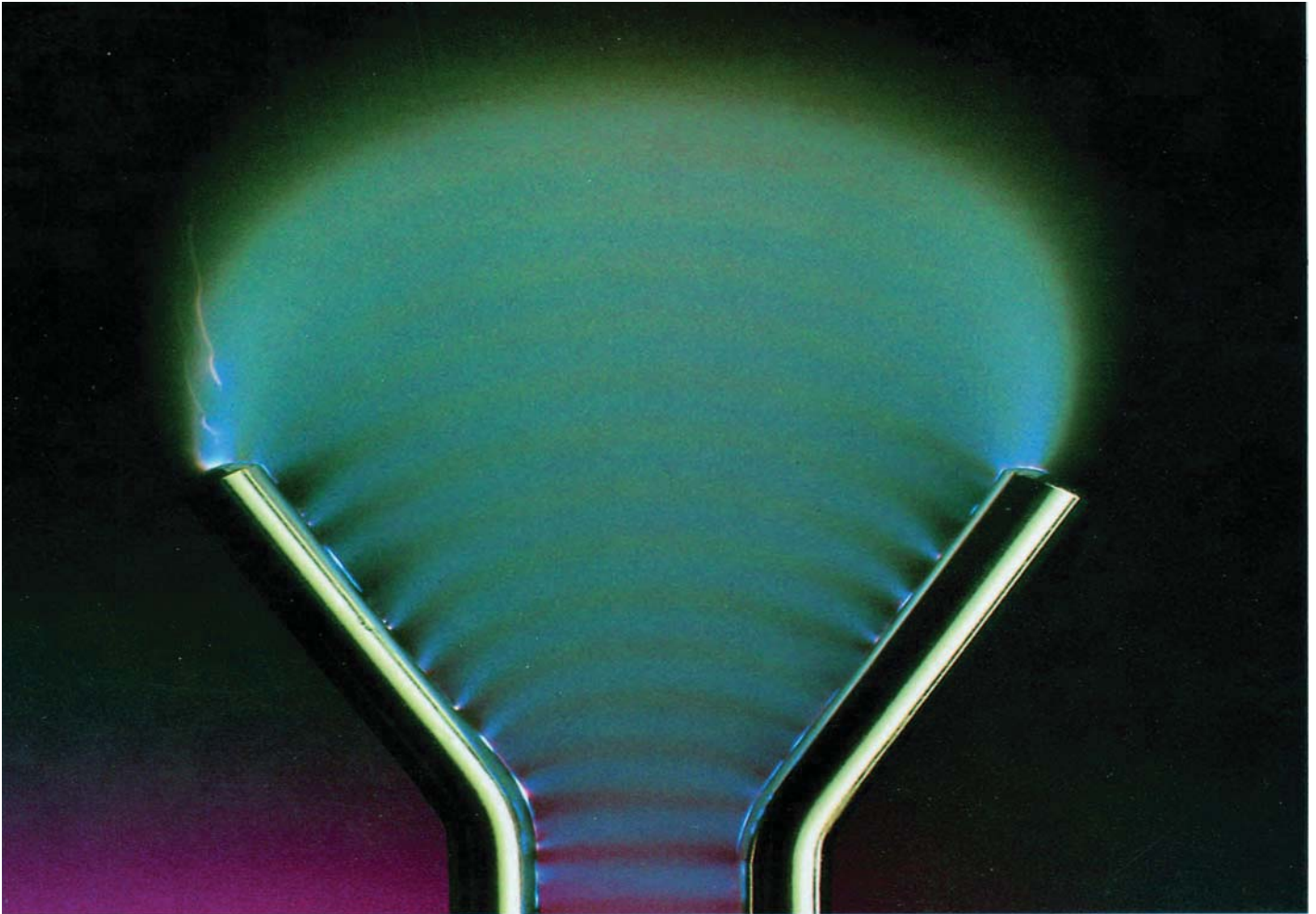

Electrical Engineering

5.1	Preparatory Courses	108
5.2	Properties of Electrical Devices	111
5.3	Properties of Electrical Circuits	131

15265-88 TESS advanced Physics Electricity / Electronics Building Block System, Basic Set Electricity

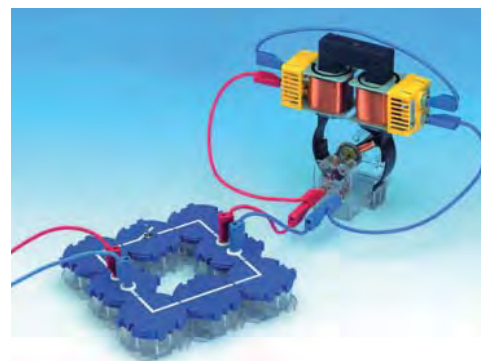

Function and Applications

Basic set allowing the performance of 29 experiments about the following topics:

- Electric circuits (8 experiments)
- Electrical resistance (8 experiments)
- Electrical work and power (1 experiment)
- Transformation of energy (1 experiment)
- Electrochemistry (6 experiments)
- Safe working with electrical energy (2 experiments)
- Sensors (3 Experiments)

Benefits

- Complete equipment set: simple execution of the experiments
- The equipment is stored in a rugged, stackable and compact box, allowing quick control of completeness (foam insert)
- Experimenting literature for pupils and teachers available: minimal preparation time
- Matched with international curriculum: all topics are covered
- The circuits are assembled directly on student's desk and the safe electric contact is guaranteed by the use of a unique puzzle block system with corrosion-free gold plated contacts. No breadboard is required.
- Rugged -PUZZLE- blocks featuring contrasted screen-printed electric symbol on top
- Easy teaching and efficient learning by using the interactive experimentation software interTESS

Equipment and technical data

- The equipment set consists of all necessary components for the experiments
- Robust, stackable storage box with a foam insert fitting to the contained equipment

Supplementary Sets

TESS advanced Physics Electricity/Electronics Building Block System, supplementary set Electromagnetism and Induction

15266-88

TESS advanced Physics Electricity/Electronics Building Block System, supplementary set Electronics

15267-88

Accessories

TESS advanced Electronics necessary accessories for 1 group

13470-88

Literature and Software

TESS Physics manual Electric/Electronic Building Block System, Part 1 and 2

01006-02

Software interTESS Physics, Electrics / Electronics, DVD

01054-00

TESS advanced Physics set Electric motor/ Generator



Function and Applications

Modular system for student experiments to work out physical and technical basic relations common to electric motors, generators and transformers. This variable system, which consists of single parts, allows to set up different function models without tools:

- Various DC motors
- Series and shunt motor
- Synchronous motor
- DC generator and alternator
- Transformer

This set allows the performance of 10 student experiments about the following topics:

- Magnetic field of a coil
- Conversion of electrical energy into kinetic energy
- Commutator; Direct current motor; Synchronous motor
- Series and shunt-wound motors; Electromagnetic induction
- Electrical generator; Engine-generator; Transformer

Benefits

- Complete equipment set: simple execution of the experiments
- The equipment is stored in a rugged, stackable and compact box, allowing quick control of completeness (foam insert)
- Experimenting literature for pupils and teachers available: minimal preparation time
- Matched with international curriculum: all topics are covered

15221-88

Accessories

TESS advanced Electric Motor / Generator EMG necessary accessories for 1 group

13412-88

Literature

TESS advanced Physics manual Electric Motor / Generator

07880-02

TESS advanced Physics set Equipotential lines and electric fields



Function and Applications

Set for simple measurement and recording of equipotential lines of different electrode configurations without electrolytes on electrically conducting paper. This set allows the performance of 5 student experiments about the following topics:

- Electric fields
- Electric field strength
- Inhomogeneous electric fields (dipole fields)
- Electric conductor as an equipotential surface
- Electrostatic tip-shape effect

Benefits

- Complete equipment set: simple execution of the experiments
- The equipment is stored in a rugged, stackable and compact box, allowing quick control of completeness (foam insert)
- Experimenting literature for pupils and teachers available: minimal preparation time
- Matched with international curriculum: all topics are covered

15250-88

Accessories

TESS advanced Equipotential lines necessary accessories for 1 group

13411-88

Literature and Software

TESS advanced Physics manual Equipotential lines and Electric field

13029-02

Software interTESS Physics, Electrostatics / Magnetism, Equipotential lines, DVD

01055-00

Electrochemical measurement set



Function and Applications

Equipment set to evaluate the principles of electrochemistry.

Equipment and technical data

The manual with detailed description of 23 experiments is included in the extent of delivery of the equipment set.

30505-77

Accessories

TESS advanced Chemistry Electrochemical measurement set
EC necessary accessories for 1 group

13422-88

Literature

TESS advanced manual Electrochemical measurement set

01194-02

TESS advanced Physics set Magnetism, MAG



Function and applications

Equipment set to perform 11 student experiments for the following topics:

- Magnetic interaction (3 experiments)
- Magnetic induction (3 experiments)
- Magnetic fields (5 experiments)

Equipment and technical data

Comprising the 10 items following incl. storage box and foam insert

- Bar magnet, $l = 50$ mm
- 2 polycarbonate plates, $136 \times 112 \times 1$ mm
- Pocket compass
- Magnetic field sensor
- Earth globe model for magnetism 8×60 mm
- Magnet, $d = 8$ mm, $l = 60$ mm
- Conductors/ non-conductors, $l = 50$ mm
- Sprinkler with iron powder, 25 ml
- Iron wire, notched

13230-77

Literature and Software

TESS advanced Physics manual Magnetism

01162-02

Software interTESS Physics, Electrostatics / Magnetism,
Equipotential lines, DVD

01055-00

You need more information? WEB@PHYWE
Just click www.phywe.com



Characteristic curves of semiconductors (with Cobra4)

P2410960

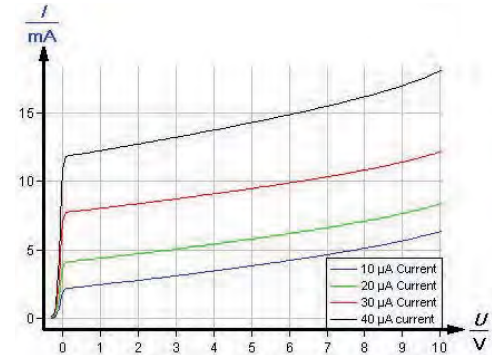
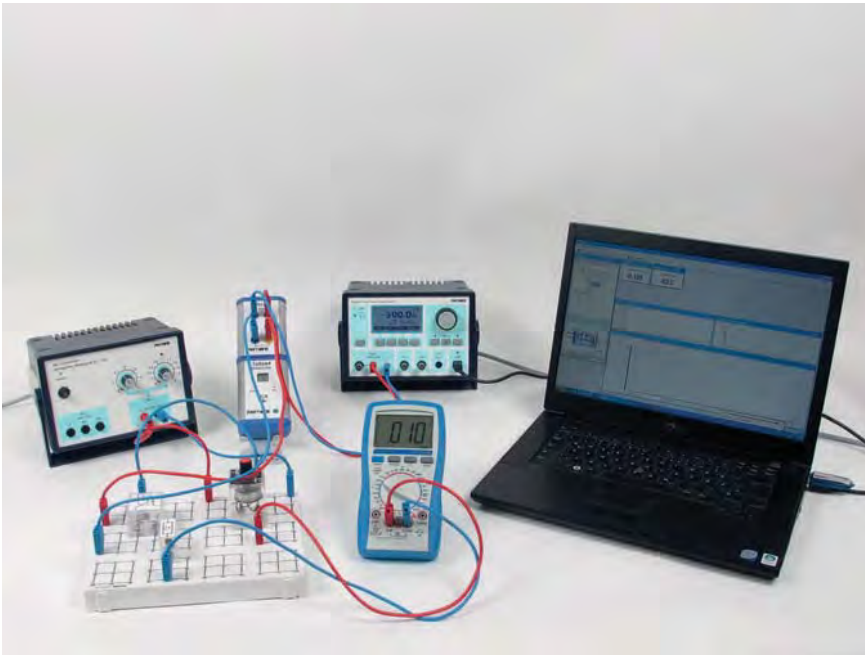

Collector current/voltage characteristic of BC337 transistor.

Principle

The current-voltage characteristic of a semiconducting diode is measured.

The collector current in dependency on the emitter-collector voltage is measured for different values of base current strength through a NPN transistor.

Tasks

1. To investigate the dependence of the current strength flowing through a semi-conducting diode.
2. To determine the variations of the collector current with the collector voltage for various values of the base current intensity.

What you can learn about

- Semiconductor; p-n junction; Energy-band diagram
- Acceptors; Donors; Valence band
- Conduction band; Transistor; Operating point

Main articles

Cobra4 Wireless Manager	12600-00	1
Cobra4 Wireless-Link	12601-00	1
Cobra4 Sensor-Unit Energycurrent, voltage, power, energy	12656-00	1
Digital Function Generator, USB, incl. Cobra4 Software	13654-99	1
Power supply 0...12 V DC/ 6 V, 12 V AC, 230 V	13505-93	1
Plug-in board,4mm plugs	06033-00	1
DMM with NiCr-Ni thermo couple	07122-00	1

Digital Function Generator, USB, incl. Cobra4 Software



Function and Applications

Digital signal generator for use as a programmable voltage source in practical or demonstration experiments, particularly in the disciplines of acoustics, electrical engineering and electronics.

Benefits

- Can be used as universal stand-alone device or controlled via a USB interface
- Universally applicable thanks to broad, continually adjustable frequency range
- Usable as programmable voltage source via amplifier output
- Intuitive, menu-driven operation using control knob and function buttons, with help capability
- Illuminated monochrome graphic display for maximum visibility and readability
- Simple setting of voltage and frequency ramps in stand-alone mode

13654-99

P2410460 Temperature dependance of different resistors and diodes (with Cobra4)

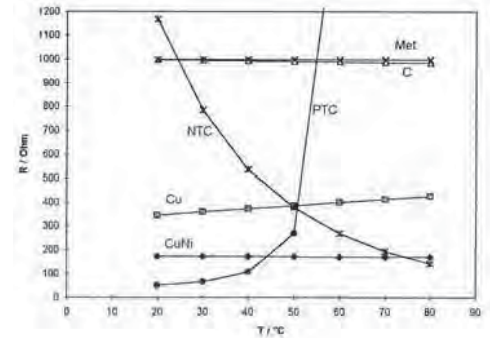
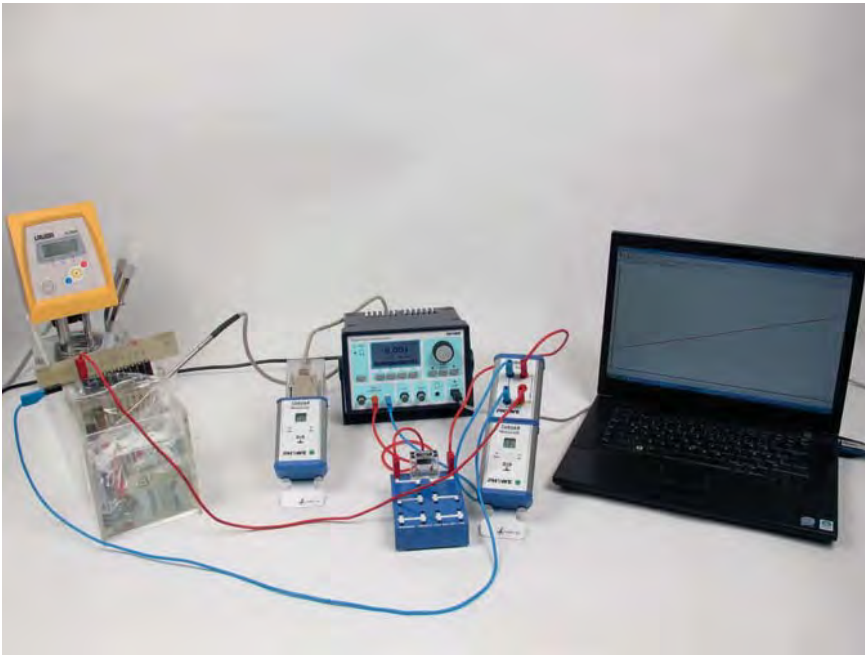

Diagram of resistances.

Principle

The temperature dependence of an electrical parameter (e.g. resistance, conducting-state voltage, blocking voltage) of different components is determined. To do this, the immersion probe set is immersed in a water bath and the resistance is measured at regular temperature intervals.

Tasks

1. Measurement of the temperature dependence of the resistance of different electrical components.
2. Measurement of the temperature dependence of the conducting state voltage of semiconducting diodes.
3. Measurement of the temperature dependence of the voltage in the Zener and the avalanche effects.

What you can learn about

- Carbon film resistor; Metallic film resistor
- PTC; NTC; Z diode; Avalanche effect
- Zener effect; Charge carrier generation
- Free path; Mathie's rule

Main articles

Cobra4 Wireless Manager	12600-00	1
Cobra4 Wireless-Link	12601-00	2
Cobra4 Sensor-Unit Energycurrent, voltage, power, energy	12656-00	1
Software Cobra4 - multi-user licence	14550-61	1
Immersion thermostat Alpha A, 230 V	08493-93	1
Immersion probes for determining ct	07163-00	1
Bath for thermostat, makrolon	08487-02	1

Related Experiment

Temperature dependence of different resistors and diodes with a multimeter

P2410401

Cobra4 Wireless Manager



Function and Applications

USB device for radio-based communication with the Cobra4 Wireless-Link.

Benefits

- Simply connect the device to the computer's USB port.
- Up to 99 measuring sensors can be connected to a computer.

12600-00

Dielectric constant of different materials

P2420600

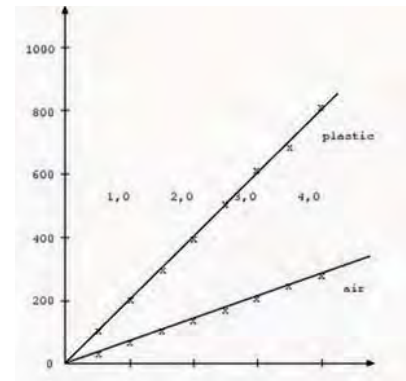

Electrostatic charge Q of a plate capacitor as a function of the applied voltage U_c , with and without dielectric (plastic) between the plates ($d = 0.98$ cm).

Principle

The electric constant is determined by measuring the charge of a plate capacitor to which a voltage is applied. The dielectric constant is determined in the same way, with plastic or glass filling the space between the plates.

Tasks

1. The relation between charge Q and voltage U is to be measured using a plate capacitor.
2. The electric constant is to be determined from the relation measured under point 1.
3. The charge of a plate capacitor is to be measured as a function of the inverse of the distance between the plates, under constant voltage.
4. The relation between charge Q and voltage U is to be measured by means of a plate capacitor, between the plates of which different solid dielectric media are introduced. The corresponding dielectric constants are determined by comparison with measurements performed with air between the capacitor plates.

What you can learn about

- Maxwell's equations; Electric constant
- Capacitance of a plate capacitor; Real charges; Free charges
- Dielectric displacement; Dielectric polarisation; Dielectric constant

Main articles

High voltage supply unit, 0-10 kV	13670-93	1
Plate capacitor, d 260mm	06220-00	1
Universal measuring amplifier	13626-93	1
Voltmeter, 0.3-300VDC, 10-300VAC /	07035-00	1
Plastic plate 283 x 283 mm	06233-01	1

High-value resistor, 10 M Ω	07160-00	1
Glass plates f.current conductors	06406-00	1

Related Experiment

Electric fields and potentials in the plate capacitor

P2420100

High voltage supply unit, 0-10 kV



Function and Applications

For electrostatic experiments and for operation of spectral and gas discharge tubes.

13670-93

P2420201 Charging curve of a capacitor / charging and discharging of a capacitor

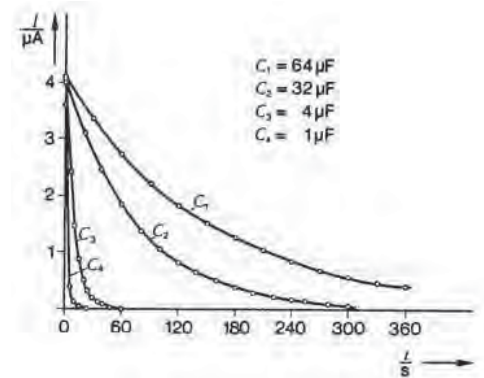

Course of current with time at different capacitance values; voltage and resistance are constant ($U = 9 \text{ V}$, $R = 2.2 \text{ M}$).

Principle

A capacitor is charged by way of a resistor. The current is measured as a function of time and the effects of capacitance, resistance and the voltage applied are determined.

Tasks

- To measure the charging current over time:
 1. using different capacitance values C , with constant voltage U and constant resistance R .
 2. using different resistance values (C and U constant).
 3. using different voltages (R and C constant).
- To determine the equation representing the current when a capacitor is being charged, from the values measured.

What you can learn about

- Charging
- Discharging
- Time constant
- Exponential function
- Half life

Main articles

Power supply 0...12 V DC/ 6 V, 12 V AC, 230 V	13505-93	1
Capacitor, 2x30 micro-F	06219-32	1
DMM, auto range, NiCr-Ni thermocouple	07123-00	1
Two-way switch, single pole	06030-00	1
Connection box	06030-23	2
Capacitor 1 microF/ 100V, G2	39113-01	1
Capacitor 4,7microF/ 100V, G2	39113-03	1

Power supply 0...12 V DC/6 V, 12 V AC, 230 V



Function and Applications

High quality power supply specially suitable for student experiments in electricity and electronics as well as for demonstration.

Equipment and technical data

- Stabilised. Shortcircuit proof
- Output voltage: 1...12 V DC, 6 V / 12 V AC
- Rated current: DC 0...2 A / AC 5 A
- Ripple: max 1 mV
- Resistance: 1 mOhm
- Mains voltage: 230 V
- Housing dimensions: 194 x 140 x 130 mm

13505-93

Switch-on behaviour of a capacitor and an inductance with the FG module (with Cobra3)

P2420715

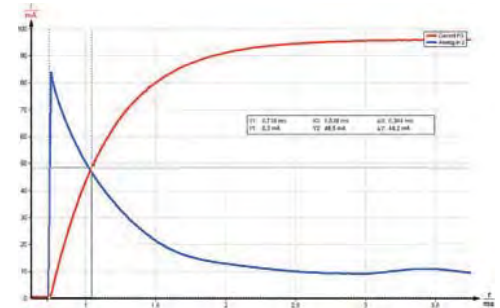

The course of the voltage and the current intensity during a switching on process in a coil.

Principle

To measure the course of current strength and voltage in a capacitance/inductivity in the instant of switching on. The capacitance/inductivity is determined from the measurement curve.

Tasks

1. To measure the course of current strength and voltage in a capacitance in the instant of switching on. The capacitance is determined from the measurement curve.
2. To measure the course of current strength and voltage in inductivity in the instant of switching on. The inductivity is determined from the measurement curve.

What you can learn about

- Charging
- Discharging
- Time constant
- Exponential function
- Half life

Main articles

Cobra3 BASIC-UNIT, USB	12150-50	1
Measuring module function generator	12111-00	1
Software Cobra3 PowerGraph	14525-61	1
Coil, 900 turns	06512-01	1
On/off switch	06034-01	1
Power supply 12V / 2A	12151-99	2
Connection box	06030-23	1

Cobra4 Experiment - available 2013

Switch-on behaviour of a capacitor and an inductance with the FG module (with Cobra4)

P2420760



P2440501 Capacitor in the AC circuit

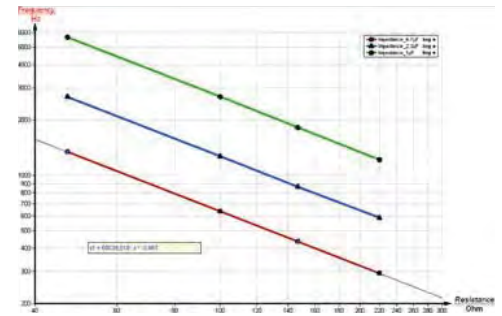
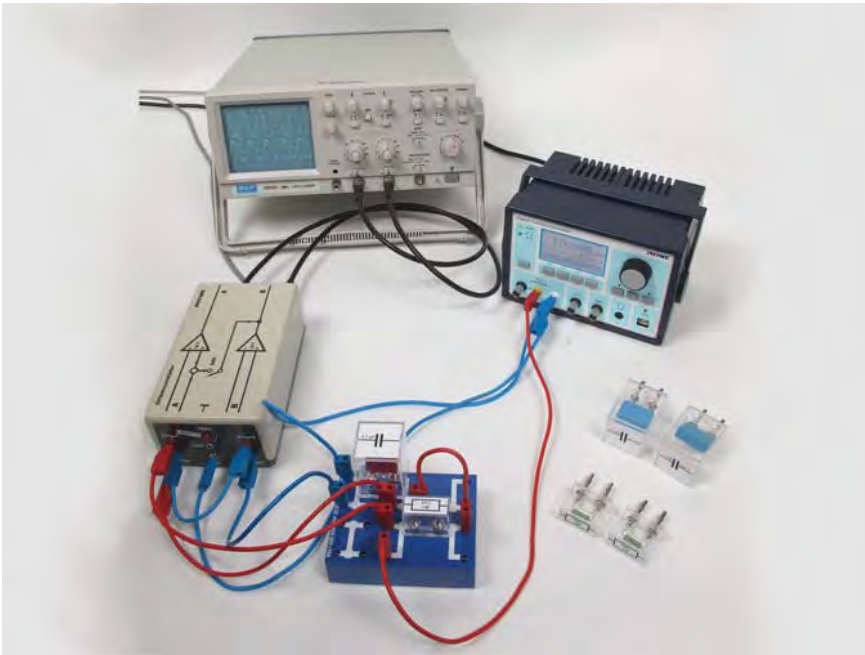

Impedance of various capacitors as a function of the frequency.

Principle

A capacitor is connected in a circuit with a variable-frequency voltage source. The impedance and phase displacement are determined as a function of frequency and of capacitance. Parallel and series impedances are measured.

Tasks

1. Determination of the impedance of a capacitor as a function of frequency.
2. Determination of the phase displacement between the terminal voltage and total current as a function of the frequency in the circuit.
3. Determination of the total impedance of capacitors connected in parallel and in series.

What you can learn about

- Capacitance
- Kirchoff's laws
- Maxwell's equations
- AC impedance
- Phase displacement

Cobra4 Experiment - available 2013

Capacitor in the AC circuit (with Cobra4)

P2440560

Difference amplifier

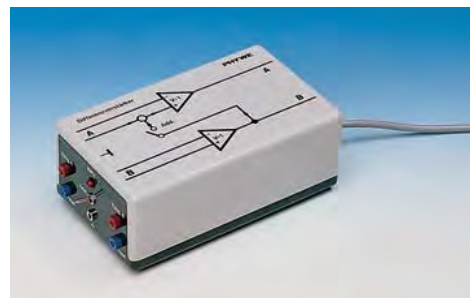

Function and Applications

For the simultaneous potential-free measurement of two voltages when connected to the inputs of a two channel oscilloscope.

Benefits

- The high resistance difference inputs can be connected to any point of a circuit, without influencing the electrical behaviour of the circuit.
- Allows demonstration of the phase shift between voltage and current in alternating current circuits.

11444-93

Main articles		
Digital Function Generator, USB, incl. Cobra4 Software	13654-99	1
30 MHz digital storage oscilloscope with colour display, 2 x BNC cables l =75 cm incl.	11462-99	1
Difference amplifier	11444-93	1
Connection box	06030-23	1
Capacitor 1 microF/ 100V, G2	39113-01	1
Capacitor 2,2microF/ 100V, G2	39113-02	1
Capacitor 4,7microF/ 100V, G2	39113-03	1

Coil in the AC circuit

P2440401

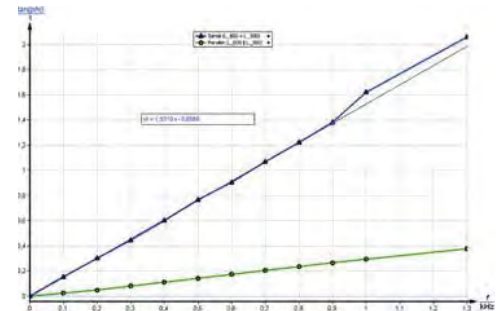
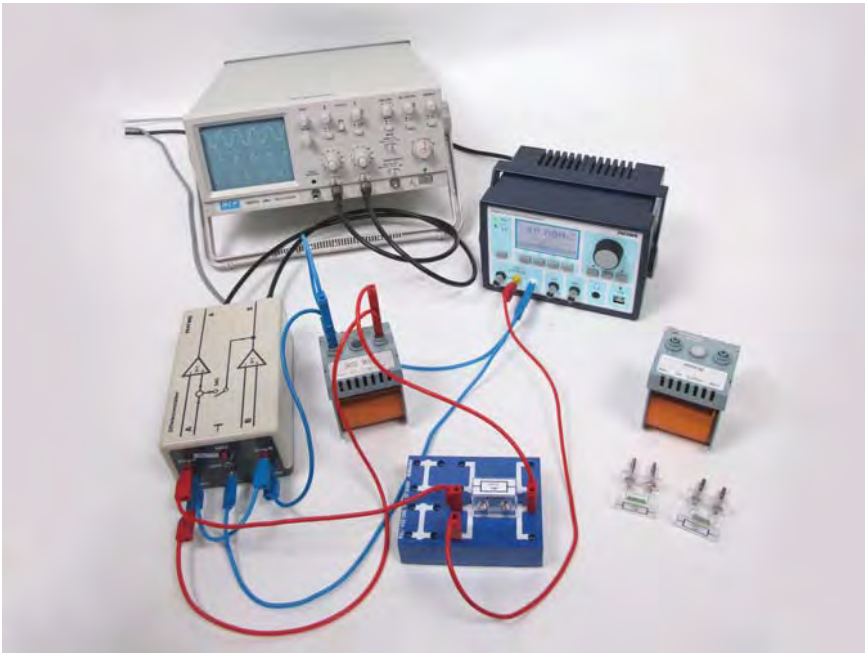

Tangent of the current-voltage phase displacement as a function of the frequency used for calculation of the total inductance of coils connected in parallel and in series.

Principle

The coil is connected in a circuit with a voltage source of variable frequency. The impedance and phase displacements are determined as functions of frequency. Parallel and series impedances are measured.

Tasks

1. Determination of the impedance of a coil as a function of frequency.
2. Determination of the inductance of the coil.
3. Determination of the phase displacement between the terminal voltage and total current as a function of the frequency in the circuit.
4. Determination of the total impedance of coils connected in parallel and in series.

What you can learn about

- Inductance; Kirchhoff's laws
- Maxwell's equations
- AC impedance; Phase displacement

Main articles

Digital Function Generator, USB, incl. Cobra4 Software	13654-99	1
30 MHz digital storage oscilloscope with colour display, 2 x BNC cables l =75 cm incl.	11462-99	1
Difference amplifier	11444-93	1
Coil, 300 turns	06513-01	1
Coil, 600 turns	06514-01	1
Connection box	06030-23	1
Resistor 50 Ohm 2%, 1W, G1	06056-50	1

Cobra4 Experiment - available 2013

Coil in the AC circuit (with Cobra4)

P2440460



P2430260 Magnetic field of single coils/ Biot-Savart's law (with Cobra4)

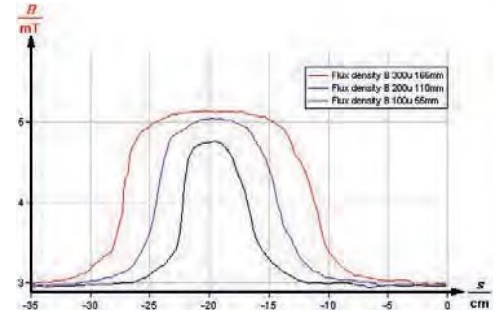
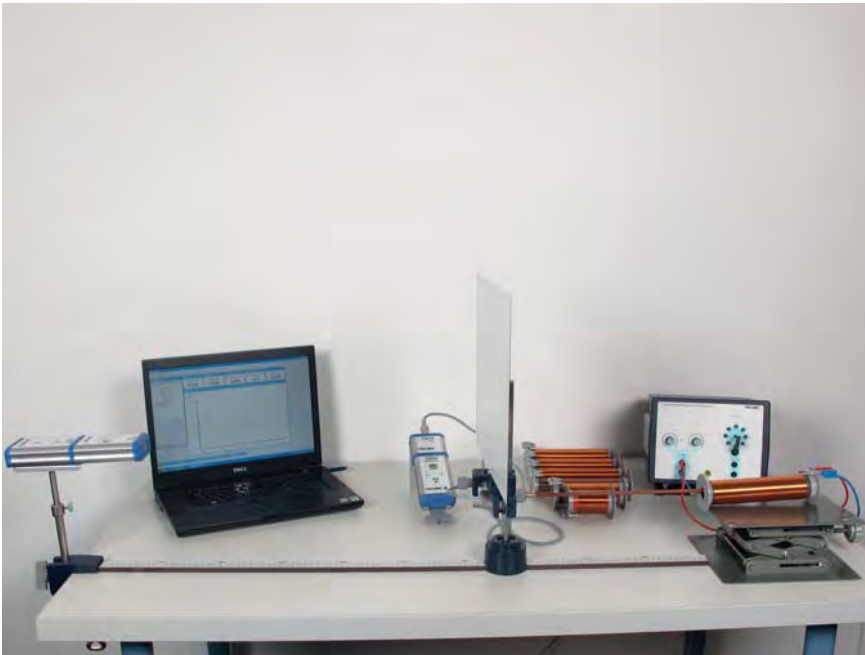

Curve of magnetic flux density (measured values) for coils with a constant density of turns n/l , coils radius $R = 20$ mm, lengths $l_1 = 53$ mm, $l_2 = 105$ mm and $l_3 = 160$ mm.

Principle

The magnetic field along the axis of wire loops and coils of different dimensions is measured with a teslameter (Hall probe). The relationship between the maximum field strength and the dimensions is investigated and a comparison is made between the measured and the theoretical effects of position.

Tasks

1. To measure the magnetic flux density in the middle of various wire loops with the Hall probe and to investigate its dependence on the radius and number of turns.
2. To determine the magnetic field constant.
3. To measure the magnetic flux density along the axis of long coils and compare it with theoretical values.

What you can learn about

- Wire loop; Biot-Savart's law
- Hall effect; Magnetic field
- Induction
- Magnetic flux density

Main articles

Cobra4 Wireless-Link	12601-00	2
Cobra4 Sensor Tesla, magnetic field strength, resolution max. ± 0.01 mT	12652-00	1
Cobra4 Sensor-Unit Electricity, Current ± 6 A / Voltage ± 30	12644-00	1
Software Cobra4 - multi-user licence	14550-61	1
Power supply, universal	13500-93	1
Hall probe, axial	13610-01	1
Conductors, circular, set	06404-00	1

Related Experiment

Magnetic field of single coils/ Biot-Savart's law with a teslameter

P2430201

Cobra4 Sensor Tesla, magnetic field strength, resolution max. ± 0.01 mT



Function and Applications

Sensor out of the Cobra4 family to measure the magnetic field strength in DC and AC fields. This sensor is suitable for the connection of the Hall probes.

12652-00

Induction impulse (with Cobra3)

P2441211

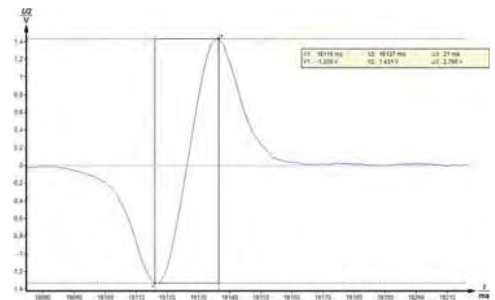

Measured induction voltage USS versus time. Additionally the evaluation of the peak-to-peak voltage USS = 2.766 V is shown.

Principle

A permanent magnet falls with different velocities through a coil. The change in the magnetic flux Φ generates an induced voltage impulse. The induced voltage impulse USS is recorded with a computer interface system. Depending on the polarity of the permanent magnet the induced voltage impulse is negative or positive.

Tasks

1. Measurement of the induced voltage impulse USS and the falling magnet's velocity.
2. Evaluation of the induced voltage impulse USS as a function of the magnet's velocity.
3. Calculation of the magnetic flux induced by the falling magnet as a function of the magnet's velocity.

What you can learn about

- Law of induction
- Magnetic flux
- Maxwell's equations

Main articles

Cobra3 BASIC-UNIT, USB	12150-50	1
Light barrier, compact	11207-20	1
Coil, 600 turns, short	06522-01	1
Tripod base PHYWE	02002-55	1
Power supply 12V / 2A	12151-99	1
Software Cobra3 Universal recorder	14504-61	1
Coil holder	06528-00	1

Cobra4 Experiment - available 2013

Induction impulse (with Cobra4)

P2441260

Cobra4 Sensor-Unit Electricity, Current ± 6 A / Voltage ± 30



Function and Applications

The Cobra4 Sensor-Unit Electricity is a secured measuring sensor, which can be connected to the Cobra4 Wireless-Link, the Cobra4 Mobile-Link, the Cobra4 Junior-Link or the Cobra4 USB-Link using a secure and reliable plug-in / lockable connection.

12644-00

P2440260 Magnetic Induction (with Cobra4)

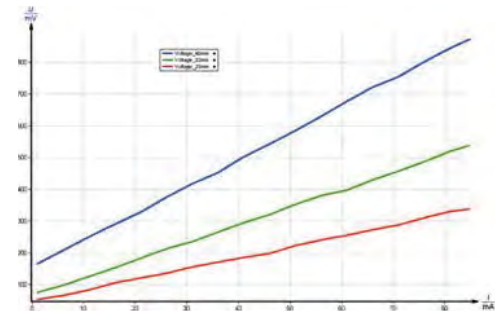

Induced voltage as a function of current for different coils.

Principle

A magnetic field of variable frequency and varying strength is produced in a long coil. The voltages induced across thin coils which are pushed into the long coil are determined as a function of frequency, number of turns, diameter and field strength.

Tasks

- Determination of the induction voltage as a function
 1. of the strength of the magnetic field,
 2. of the frequency of the magnetic field,
 3. of the number of turns of the induction coil,
 4. of the cross-section of the induction coil.

What you can learn about

- Maxwell's equations; Electrical eddy field
- Magnetic field of coils; Coil; Magnetic flux
- Induced voltage

Main articles

Cobra4 Wireless Manager	12600-00	1
Cobra4 Wireless-Link	12601-00	1
Cobra4 Sensor-Unit Electricity, Current ± 6 A / Voltage ± 30	12644-00	1
Digital Function Generator, USB, incl. Cobra4 Software	13654-99	1
Field coil, 750 mm, 485 turns/m	11001-00	1
Induction coil, 300 turns, dia. 40mm	11006-01	1
Induction coil, 300 turns, dia. 32mm	11006-02	1

Related Experiment

Magnetic induction

P2440201

Cobra4 Wireless-Link



Function and Applications

Interface module for the radio-based transmission of sensor measuring values in conjunction with the Cobra4 Wireless Manager.

12601-00

Inductance of solenoids

P2440301

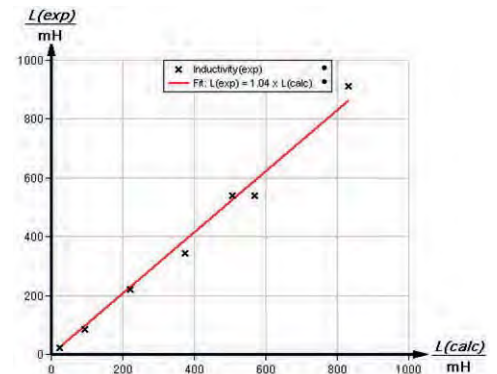

Inductance per turn as a function of the length of the coil at constant radius.

Measurement of the oscillation period with the "Survey Function".

Principle

A square wave voltage of low frequency is applied to oscillatory circuits comprising coils and capacitors to produce free, damped oscillations. The values of inductance are calculated from the natural frequencies measured, the capacitance being known.

Tasks

- To connect coils of different dimensions (length, radius, number of turns) with a known capacitance C to form an oscillatory circuit.
- From the measurements of the natural frequencies, to calculate the inductances of the coils and determine the relationships between:
 1. inductance and number of turns
 2. inductance and length
 3. inductance and radius.

What you can learn about

- Lenz's law; Self-inductance; Solenoids; Transformer
- Oscillatory circuit; Resonance; Damped oscillation
- Logarithmic decrement; Q factor

Main articles

Digital Function Generator, USB, incl. Cobra4 Software	13654-99	1
30 MHz digital storage oscilloscope with colour display, 2 x BNC cables l =75 cm incl.	11462-99	1
Coil, 1200 turns	06515-01	1
Induction coil,300 turns,dia.40mm	11006-01	1
Induction coil,300 turns,dia.32mm	11006-02	1
Induction coil,300 turns,dia.25mm	11006-03	1
Induction coil,200 turns,dia.40mm	11006-04	1

Cobra4 Experiment - available 2013

Inductance of solenoids (with Cobra4)

P2440360

Induction coil,300 turns,dia.40mm



Function and Applications

To investigate electromagnetic induction together with field coil (11001-00) and the constitution of magnetic fields within long coils.

11006-01

P2441101 Resistance, phase shift and power in AC circuits with digital function generator

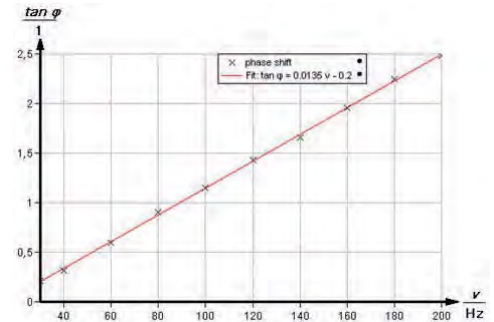
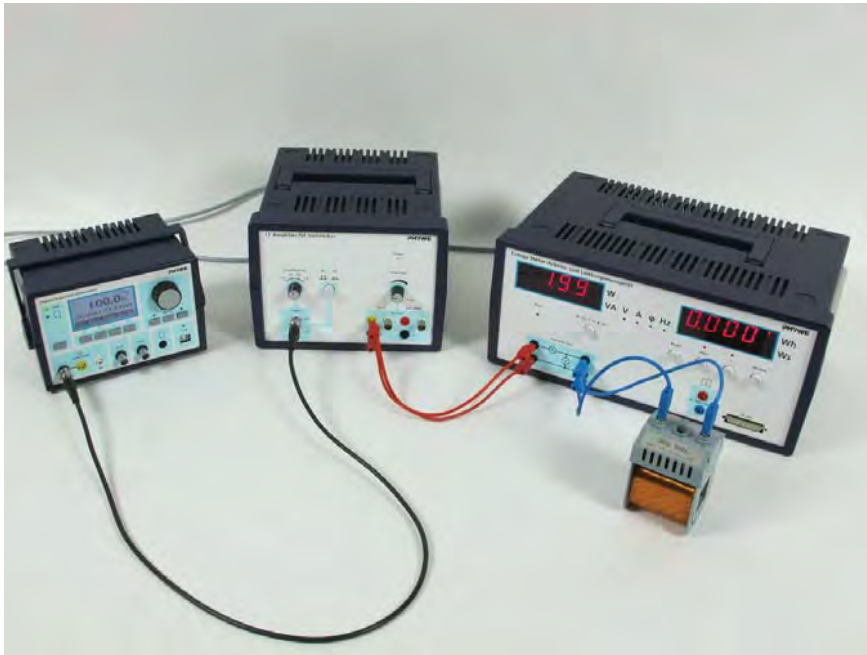

Self-inductance and resistor in series: $\tan \phi$ as a function of v .

Principle

Series circuits containing self-inductances or capacitances and ohmic resistances are investigated as a function of frequency. Measuring the electrical magnitudes with a work or power measurement instrument, real power or apparent power can be displayed directly.

Tasks

Series circuit of self-inductance and resistor (real coil)

- Investigation of impedance and phase shift as a function of frequency.
- Investigation of the relation between real power and current intensity.
- Determination of self-inductance and ohmic resistance.

Series circuit of capacitor and resistor

- Investigation of impedance and phase shift as a function of frequency.
- Investigation of the relation between real power and current intensity.
- Determination of capacitance and ohmic resistance.

What you can learn about

- Impedance; Phase shift; Phasor diagram
- Capacitance; Self-inductance

Main articles

Work and power meter	13715-93	1
LF amplifier, 220 V	13625-93	1
Digital Function Generator, USB, incl. Cobra4 Software	13654-99	1
Coil, 300 turns	06513-01	1
Connection box	06030-23	1

Work and power meter



Function and Applications

For AC and DC circuits.

Equipment and technical data

- Two 4-digit, 20 mm LED-displays
- Display 1 for real and apparent power, current, voltage, phase difference and frequency
- Display 2 for energy and time, selector for serial display of all units
- LED-Status-display and automatic range selection
- Power: max. 2400 W, Resolution: max. 0.001 W
- Voltage: 0-30V AC/DC, 0-240, Veff- Current: 0...10A AC/DC
- Phasen difference: 0...+/- 90 degree
- Frequency: 0...10000 Hz, Energy: max. 9999 Wh or Ws
- Resolution: max. 0.001 Ws, Analog output for all units of disp. 1
- Mains: 110/230V, 50/60Hz
- Shock-resistant plastic housing with carry handle and base

13715-93

Transformer

P2440100

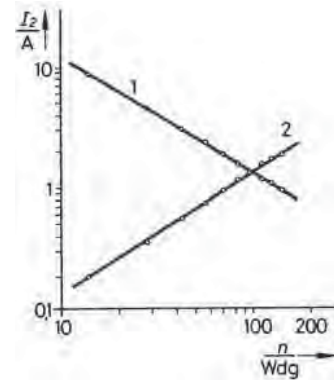

Secondary short-circuit current of the transformer as a function 1. of the number of turns in the secondary coil, 2. of the number of turns in the primary coil.

Principle

An alternating voltage is applied to one of two coils (primary coil) which are located on a common iron core. The voltage induced in the second coil (secondary coil) and the current flowing in it are investigated as functions of the number of turns in the coils and of the current flowing in the primary coil.

Tasks

- The secondary voltage on the open circuited transformer is determined as a function
 1. of the number of turns in the primary coil,
 2. of the number of turns in the secondary coil,
 3. of the primary voltage.
- The short-circuit current on the secondary side is determined as a function
 1. of the number of turns in the primary coil,
 2. of the number of turns in the secondary coil,
 3. of the primary current.
- With the transformer loaded, the primary current is determined as a function
 1. of the secondary current,
 2. of the number of turns in the secondary coil,
 3. of the number of turns in the primary coil.

What you can learn about

- Induction
- Magnetic flux
- Loaded transformer
- Unloaded transformer
- Coil

Main articles

Multitap transformer, 14 VAC/ 12 VDC, 5 A	13533-93	1
Coil, 140 turns, 6 tapplings	06526-01	2
Rheostat, 10 Ohm , 5.7A	06110-02	1
Clamping device	06506-00	1
Iron core, U-shaped, laminated	06501-00	1
Two-way switch, double pole	06032-00	1
DMM with NiCr-Ni thermo couple	07122-00	3

Multitap transformer, 14 VAC/ 12 VDC, 5 A



Function and Applications

Power supply unit for low voltage supplies DC and AC voltages in 2 V steps.

13533-93

P2530300 Hall effect in metals

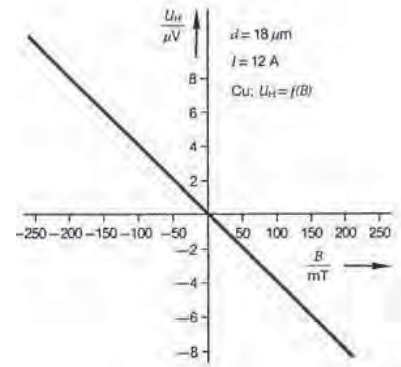
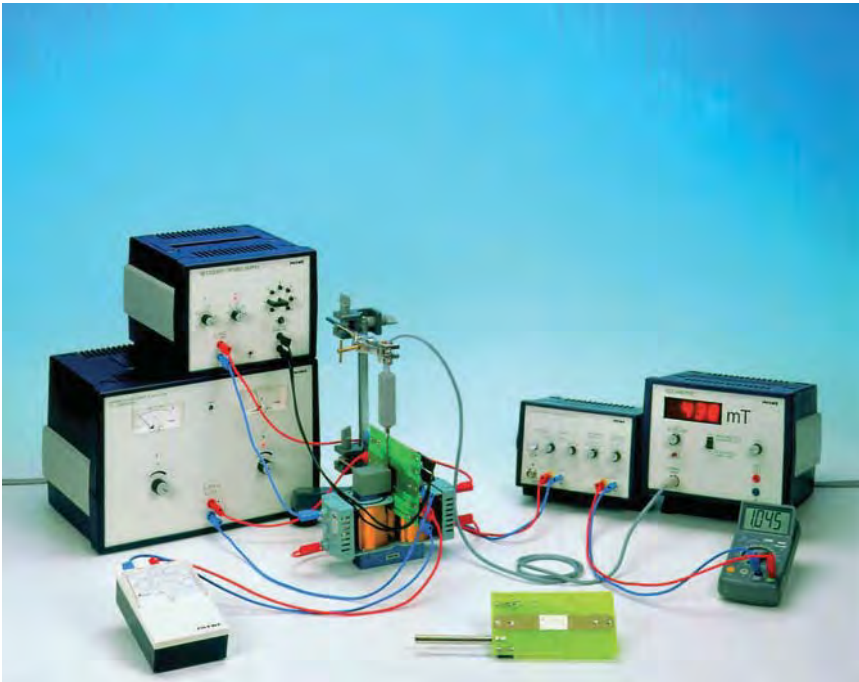

Hall voltage as a function of magnetic induction B, using a copper sample.

Principle

The Hall effect in thin zinc and copper foils is studied and the Hall coefficient determined. The effect of temperature on the Hall voltage is investigated.

Tasks

1. The Hall voltage is measured in thin copper and zinc foils.
2. The Hall coefficient is determined from measurements of the current and the magnetic induction.
3. The temperature dependence of the Hall voltage is investigated on the copper sample.

What you can learn about

- Normal Hall effect
- Anomalous Hall effect
- Charge carriers
- Hall mobility
- Electrons
- Defect electrons

Main articles

Power supply 0-30VDC/20A, stabil	13536-93	1
Teslameter, digital	13610-93	1
Universal measuring amplifier	13626-93	1
Power supply, universal	13500-93	1
Hall effect, Cu, carrier board	11803-00	1
Hall effect, zinc, carrier board	11804-01	1
Hall probe, tangential, protection cap	13610-02	1

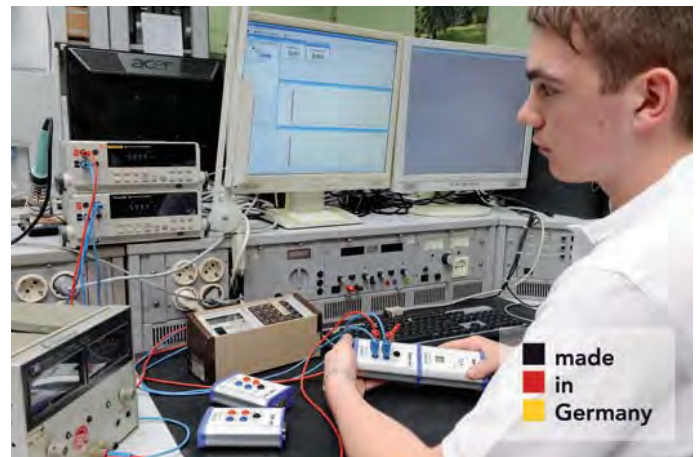

Hall effect in p-germanium

P2530101

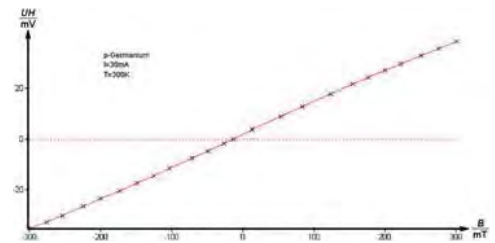

Hall voltage as a function of magnetic induction.

Principle

The resistivity and Hall voltage of a rectangular germanium sample are measured as a function of temperature and magnetic field. The band spacing, the specific conductivity, the type of charge carrier and the mobility of the charge carriers are determined from the measurements.

Tasks

1. The Hall voltage is measured at room temperature and constant magnetic field as a function of the control current and plotted on a graph (measurement without compensation for defect voltage).
2. The voltage across the sample is measured at room temperature and constant control current as a function of the magnetic induction B .
3. The voltage across the sample is measured at constant control current as a function of the temperature. The band spacing of germanium is calculated from the measurements.
4. The Hall voltage U_H is measured as a function of the magnetic induction B , at room temperature. The sign of the charge carriers and the Hall constant R_H together with the Hall mobility m_H and the carrier concentration p are calculated from the measurements.
5. The Hall voltage U_H is measured as a function of temperature at constant magnetic induction B and the values are plotted on a graph.

What you can learn about

- Semiconductor; Band theory; Forbidden zone
- Intrinsic conductivity
- Extrinsic conductivity; Valence band
- Conduction band
- Lorentz force; Magnetic resistance
- Mobility; Conductivity; Band spacing; Hall coefficient

Main articles

Teslameter, digital	13610-93	1
Hall effect module	11801-00	1
Hall effect, p-Ge, carrier board	11805-01	1
Power supply 0...12 V DC/ 6 V, 12 V AC, 230 V	13505-93	1
Hall probe, tangential, protection cap	13610-02	1
Coil, 600 turns	06514-01	2
Iron core, U-shaped, laminated	06501-00	1

Related Experiment

Hall effect in n-germanium

P2530201

Cobra4 Experiments - available 2013

Hall effect in p-germanium (with Cobra4)

P2530160

Hall effect in n-germanium (with Cobra4)

P2530260

P2530401 Band gap of germanium

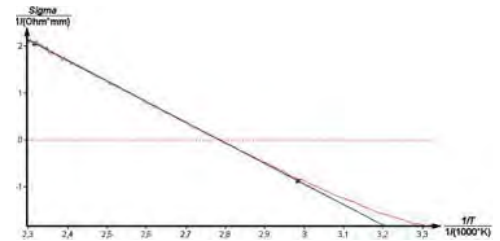

Regression of the conductivity versus the reciprocal of the absolute temperature.

Principle

The conductivity of a germanium test piece is measured as a function of temperature. The energy gap is determined from the measured values.

Tasks

1. The current and voltage are to be measured across a germanium test-piece as a function of temperature.
2. From the measurements, the conductivity σ is to be calculated and plotted against the reciprocal of the temperature T . A linear plot is obtained, from whose slope the energy gap of germanium can be determined.

What you can learn about

- Semiconductor
- Band theory
- Forbidden band
- Intrinsic conduction
- Extrinsic conduction
- Impurity depletion
- Valence band
- Conduction band

Main articles

Hall effect module	11801-00	1
Intrins.conduct.Ge,carrier board	11807-01	1
Power supply 0...12 V DC/ 6 V, 12 V AC, 230 V	13505-93	1
Tripod base PHYWE	02002-55	1
Digital multimeter 2010	07128-00	2
Support rod PHYWE,square,l 250mm	02025-55	1
Right angle clamp PHYWE	02040-55	1

Related Experiment

Band gap of germanium (with Cobra3)
P2530411

Cobra4 Experiment - available 2013

Band gap of germanium (with Cobra4)
P2530460

You need more information? WEB@PHYWE
Just click www.phywe.com

Nernst equation (with Cobra4)

P3060962

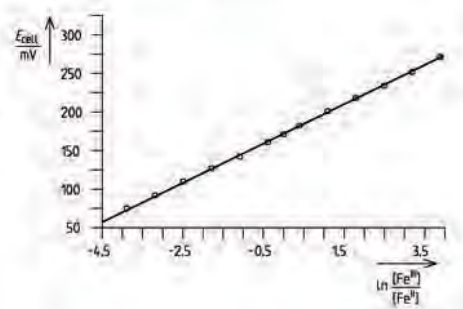

Verification of the Nernst equation for the $\text{Fe}(\text{CN})_6^{4-}$, $\text{Fe}(\text{CN})_6^{3-}$ Pt redox electrode.

Principle

The Nernst equation expresses how the electrical potential of an electrode in contact with a solution of ions depends upon the concentrations (more accurately, activities) of those ions. The equation may be experimentally verified using an electrochemical cell formed from an inert indicator electrode coupled with a convenient reference electrode. The potential of the indicator electrode, and hence the e.m.f. of the cell, is monitored as the ionic composition of the electrolyte solution is changed.

Tasks

Using an $\text{Ag}(\text{S}) \mid \text{AgCl}(\text{S}) \mid \text{Cl}^-$ reference electrode, measure the potential of a platinum electrode in contact with solutions containing known concentration of the iron(II) and iron(III) complex ions $[\text{Fe}(\text{CN})_6]^{4-}$ and $[\text{Fe}(\text{CN})_6]^{3-}$.

What you can learn about

- Electrode potentials and their concentration dependence
- Redox electrodes
- Electrochemical cells

Main articles

Cobra4 Mobile-Link	12620-00	1
Cobra4 Sensor-Unit Chemistry, pH and 2 x Temperature NiCr-Ni	12630-00	1
Immersion probe NiCr-Ni, teflon, 300 °C	13615-05	1
Magnetic stirrer Mini / MST	47334-93	1
Reference electrode, AgCl	18475-00	1
Retort stand, h = 750 mm	37694-00	2
Set of Analytical Balance Sartorius CPA 224S and measure software, 230 V	49221-88	1

Cobra4 Sensor-Unit Chemistry, pH and 2 x Temperature NiCr-Ni



Function and Applications

The Cobra4 Sensor-Unit pH and 2 x temperature NiCr-Ni is a measuring recorder for pH, potential and temperature measurements, which is controlled by micro-controller.

Benefits

- It can be fitted with two NiCr-Ni thermoelements (Type K) and a pH probe or redox measuring chain
 - Measure up to two temperatures and one pH or potential value simultaneously.
 - Discover new experimental possibilities especially in thermodynamics
- Values of the calibration are saved in the sensor - no need for new calibration.
- The sensor is not restricted to the measurement of pH values: Connect the redox electrode 46267-10 to measure redox potentials.

12630-00

P3061262 Temperature dependence of the electromotive force (with Cobra4)

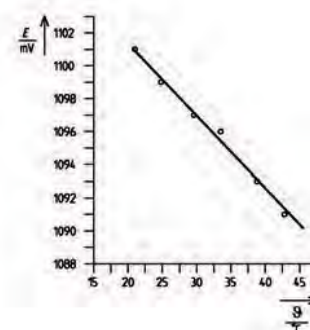
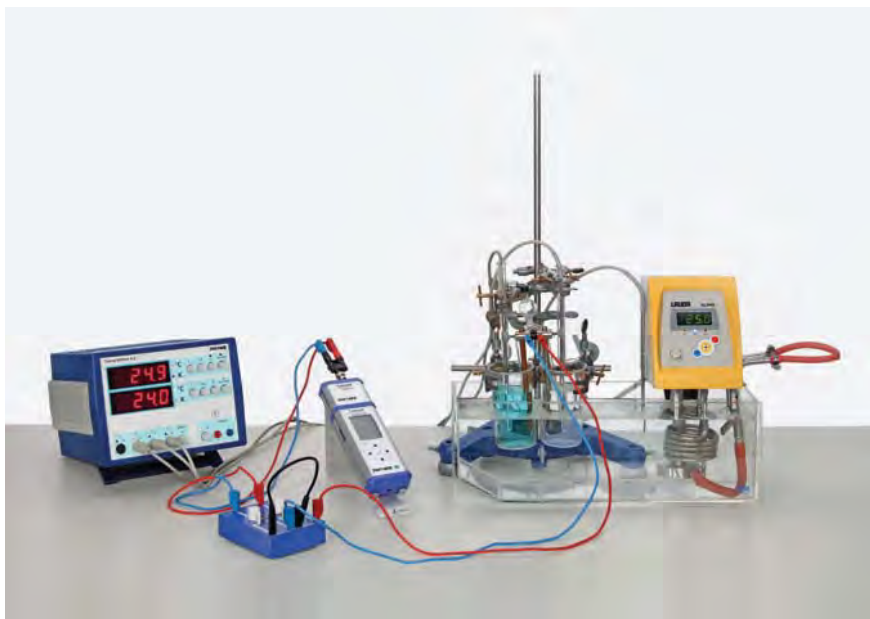

Electromotive force versus temperature.

Principle

Thermodynamic data of the gross reaction in a galvanic cell can be determined by measuring the e.m.f. at different temperatures.

Task

Determine the usable reaction equivalent work of the Daniell cell by measuring the dependence of the electromotive force on temperature.

What you can learn about

- Electromotive force
- Electrode reactions
- Electrochemical potential
- Nernst equation

Main articles

Cobra4 Mobile-Link	12620-00	1
Cobra4 Sensor-Unit Chemistry, pH and 2 x Temperature NiCr-Ni	12630-00	1
Temp. probe, immersion type, Pt100, stainless steel, -20...+300 °C	11759-01	3
Bath for thermostat, makrolon	08487-02	1
Temperature meter digital, 4-2	13617-93	1
Immersion thermostat Alpha A, 230 V	08493-93	1
Set of Precision Balance Sartorius CPA 623S and measure software, 230 V	49224-88	1

Immersion thermostat Alpha A, 230 V



Function and Applications

Immersion circulator with simple, reliable options for obtaining consistent results. Compact unit can be combined with any existing baths up to 25 mm wall thickness.

Benefits

- Wide temperature range to meet application needs.
- Digital settings for simple operation.
- Strong pump for high temperature conformity.
- To be used with water as heat transfer liquid.
- Screw clamp for bath walls up to 25 mm.
- Robust design using high grade stainless steel and temperature resistant polymer.
- Wear-free; integrated overload protection.

08493-93

Second order conductors. Electrolysis (with Cobra4)

P2411360

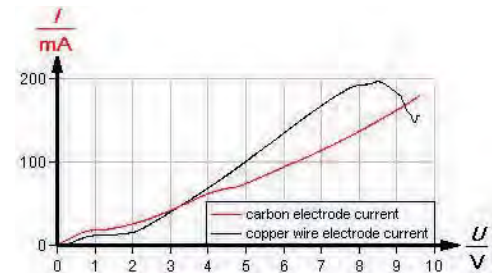

Current/voltage characteristics of an aqueous copper sulphate solution conducted with graphite electrodes and copper wires.

Principle

In this experiment a copper (II) sulphate solution is to be electrolysed using two different materials - graphite electrodes and copper wires. During the electrolyses the current / voltage curves are recorded.

Task

Measure the correlation between voltage and current on second order conductors (copper (II) sulphate solution) using two different materials - graphite electrodes and copper wires.

What you can learn about

- Electrolysis
- Electrode polarisation
- Conductivity
- Ohm's law

Main articles

Cobra4 Wireless Manager	12600-00	1
Cobra4 Wireless-Link	12601-00	1
Cobra4 Sensor-Unit Electricity, Current ± 6 A / Voltage ± 30	12644-00	1
Digital Function Generator, USB, incl. Cobra4 Software	13654-99	1
Tripod base PHYWE	02002-55	1
Holder for two electrodes	45284-01	1
Set of Precision Balance Sartorius CPA 623S and measure software, 230 V	49224-88	1

Cobra4 Sensor-Unit Electricity, Current ± 6 A / Voltage ± 30



Function and Applications

The Cobra4 Sensor-Unit Electricity is a secured measuring sensor, which can be connected to the Cobra4 Wireless-Link, the Cobra4 Mobile-Link, the Cobra4 Junior-Link or the Cobra4 USB-Link using a secure and reliable plug-in / lockable connection.

Benefits

- The sensor has a voltage difference input.
- Simultaneous measurement of current and voltage is possible.

Equipment and technical data

Measuring range:

- Voltage: $-30 \dots 30$ V. Current: $-6 \dots 6$ A.

Resolution:

- Voltage: 15 mV. Current: 3 mA.

Internal resistances:

- Voltage: 1 M Ω . Current: 33 m Ω . Weight: 100 g

12644-00

P2410700 Semiconductor thermogenerator - Seebeck effect

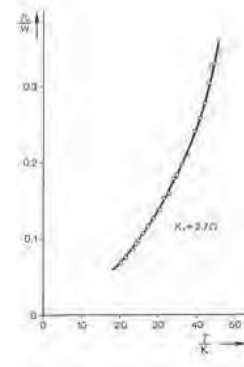

Electrical power generated as a function of the temperature difference.

Principle

In a semi-conductor thermogenerator, the no-load voltage and the short-circuit current are measured as a function of the temperature difference. The internal resistance, the Seebeck coefficient and the efficiency are determined.

Tasks

1. To measure no-load voltage U_0 and short-circuit current I_s at different temperature differences and to determine the Seebeck coefficient.
2. To measure current and voltage at a constant temperature difference but with different load resistors, and to determine the internal resistance R_i from the measured values.
3. To determine the efficiency of energy conversion, from the quantity of heat consumed and the electrical energy produced per unit time.

What you can learn about

- Seebeck effect (thermoelectric effect)
- Thermoelectric e.m.f.; Efficiency
- Peltier coefficient; Thomson coefficient
- Seebeck coefficient; Direct energy conversion
- Thomson equations

Main articles

Thermogenerator with 2 water baths	04366-00	1
Immersion thermostat Alpha A, 230 V	08493-93	1
Rheostat, 33 Ohm , 3.1A	06112-02	1
Voltmeter,0.3-300VDC,10-300VAC /	07035-00	1
Bath for thermostat, makrolon	08487-02	1
Ammeter 1/5 A DC	07038-00	1
Flow-through heat exchanger	04366-01	2

Thermogenerator with 2 water baths

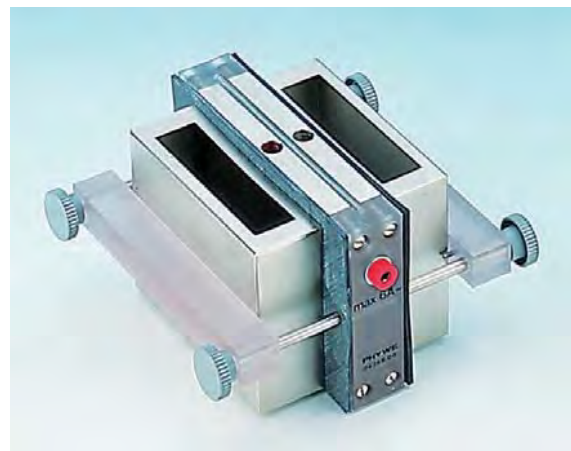

Function and Applications

To commute thermal energy into electrical energy directly and for operation as heat pump. Also been used to demonstrate the Seebeck effect and the Peltier effect.

Equipment and technical data

- Generator block consisting of two nickel coated copper plates with hole for thermometer, between these, p- and n-conducting silicon thermocouples, connected thermally parallel and electrically in series.
- Two water containers with open sides, which are used as heat reservoirs, are screwed to the generator block. They can be exchanged for flowthrough heat exchanger or air cooler.

04366-00

Ohm's law (with Cobra4)

P2410160

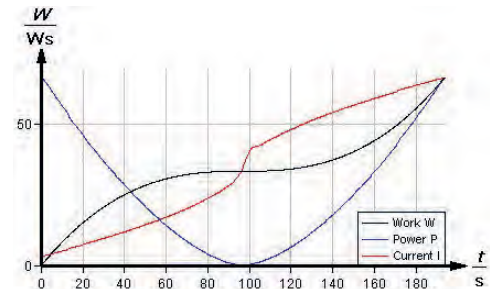
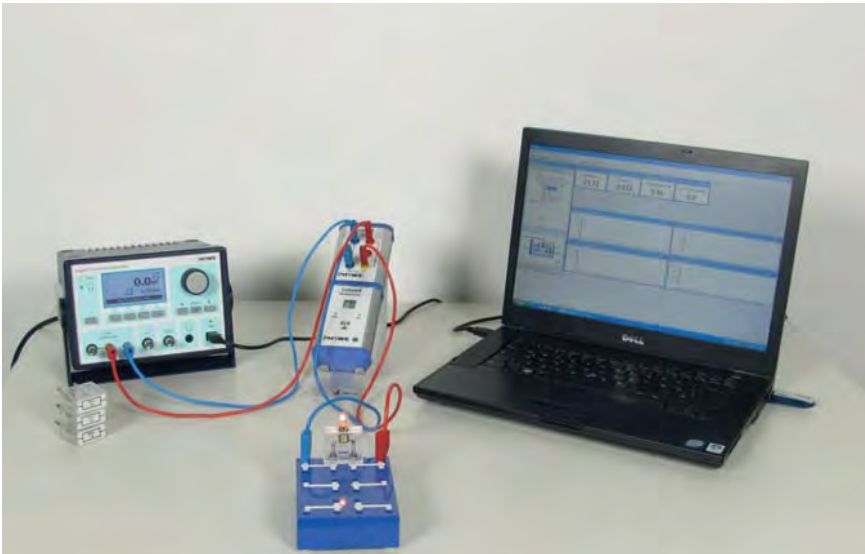

Current, Power and Work of an incandescent bulb.

Principle

The electrical resistance of pure metals increases with increasing temperature. The correlation between voltage and current is to be measured using temperature-in- and dependent resistors. Determine the work and power of an incandescent bulb.

Tasks

1. To plot the current/voltage characteristics of Ohm's resistors and of pure metals and to calculate their resistivity.
2. To determine the resistance of various connecting cords by plotting their current/characteristics and calculating the contact resistances.
3. To determine the work and power of an incandescent bulb as a function of the applied voltage.

What you can learn about

- Ohm's law
- Resistivity
- Contact resistance
- Conductivity
- Power and Work

Main articles

Digital Function Generator, USB, incl. Cobra4 Software	13654-99	1
Cobra4 Wireless Manager	12600-00	1
Cobra4 Wireless-Link	12601-00	1
Cobra4 Sensor-Unit Energycurrent, voltage, power, energy	12656-00	2
Connection box	06030-23	1
Lampholder E10, case G1	17049-00	1
resistor 100 Ohm, 1W, G1	39104-63	1

Digital Function Generator, USB, incl. Cobra4 Software



Function and Applications

Digital signal generator for use as a programmable voltage source in practical or demonstration experiments, particularly in the disciplines of acoustics, electrical engineering and electronics.

Benefits

- Can be used as universal stand-alone device or controlled via a USB interface.
- Universally applicable thanks to broad, continually adjustable frequency range.
- Usable as programmable voltage source via amplifier output
- Intuitive, menu-driven operation using control knob and function buttons, with help capability.
- Illuminated monochrome graphic display for maximum visibility and readability.
- Simple setting of voltage and frequency ramps in stand-alone mode.

13654-99

P2410560 Kirchhoff's laws (with Cobra4)

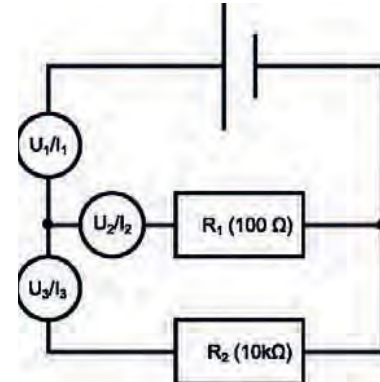
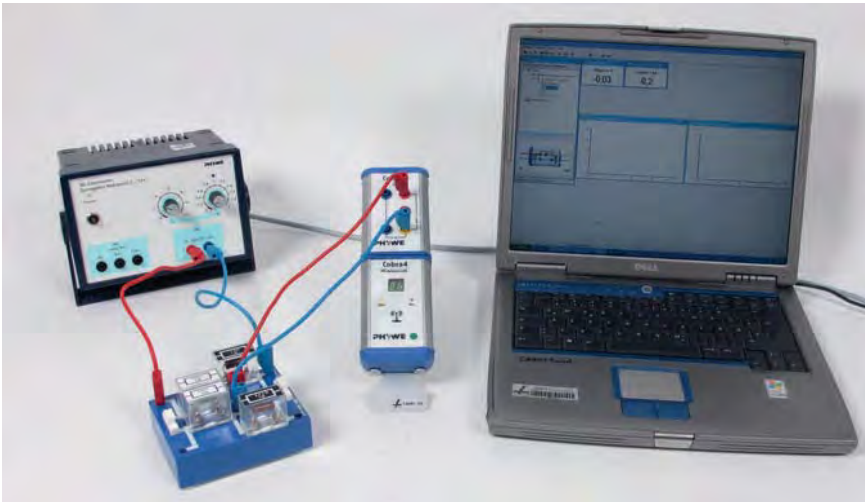

Schematic circuit for the Wheatstone bridge.

Principle

Kirchhoff's laws are verified by measuring current, voltage and resistance in series and parallel circuits. The Wheatstone bridge circuit is used to determine unknown resistances more precisely.

Tasks

1. Verify Kirchhoff's laws by measuring current and voltage for series and parallel connected resistors for each resistor as well as the total values. From these measurements calculate the partial and total resistances.
2. Determine unknown resistances by the use of the Wheatstone bridge circuit.

What you can learn about

- Kirchhoff's laws; Induction law; Maxwell equations
- Current; Voltage; Resistance
- Parallel connection; Series connection; Potentiometer

Main articles

Cobra4 Wireless Manager	12600-00	1
Cobra4 Wireless-Link	12601-00	1
Cobra4 Sensor-Unit Energy current, voltage, power, energy	12656-00	1
Software Cobra4 - multi-user licence	14550-61	1
Power supply 0...12 V DC/ 6 V, 12 V AC, 230 V	13505-93	1
Connection box	06030-23	1
Resistor 100 Ohm, 1W, G1	39104-63	1

Related Experiments

Kirchhoff's laws

P2410500

Cobra4 Sensor-Unit Energy current, voltage, power, energy



Function and Applications

The Cobra4 Sensor-Unit Energy is used for the measurement and direct indication of measurement variables of the electrical power and energy in direct current and alternating current circuits (current, voltage, effective and apparent power, angular phase shift, frequency, electric work).

Benefits

- This sensor measures directly the values for alternating current and direct current.
- This allows numerous basic as well as application-oriented experiments, e.g. the determination of the characteristics of alternating current resistances or the investigation of the energy demand of consumers.

12656-00

4 Point Method / Measurement of low resistances / Ohm's Law

P2410101

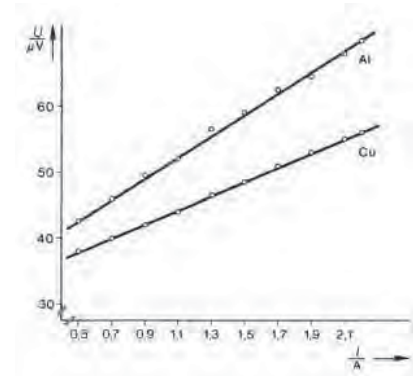

Current/voltage characteristics of a copper rod and an aluminium rod.

Principle

The resistances of various DC conductors are determined by recording the current / voltage characteristic. The resistivity of metal rods and the contact resistance of connecting cords are calculated.

Tasks

1. To plot the current / voltage characteristics of metal rods (copper and aluminium) and to calculate their resistivity.
2. To determine the resistance of various connecting cords by plotting their current / voltage characteristics and calculating the contact resistances.

What you can learn about

- Ohm's law
- Resistivity
- Contact resistance
- Conductivity
- Four-wire method of measurement

Main articles

Universal measuring amplifier	13626-93	1
Power supply 0...12 V DC/ 6 V, 12 V AC, 230 V	13505-93	1
Heat conductivity rod, Cu	04518-11	1
Heat conductivity rod, Al	04518-12	1
Digital multimeter 2010	07128-00	2
Connection box	06030-23	1

Universal measuring amplifier



Function and Applications

Universal measuring amplifier for amplification of AC and DC voltages. Suitable for practical exercises.

Equipment and technical data

input impedance:

electrometer: > 10 (13) Ohm

low drift: 10 kOhm

- input voltage: -10 to + 10 V
- output voltage: -10 to + 10 V

13626-93

P2441005 RLC measuring bridge

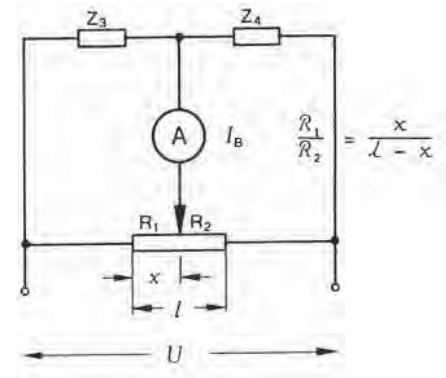
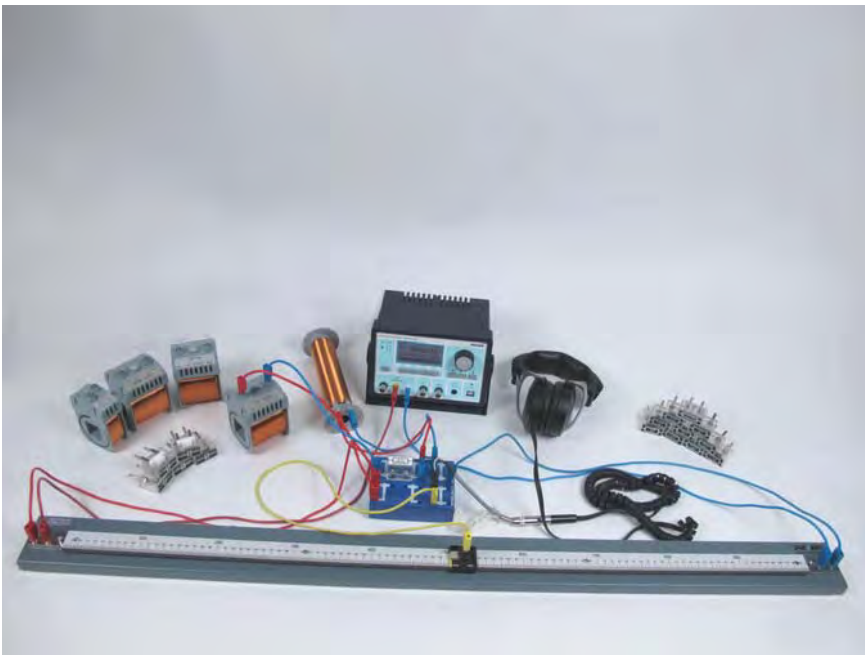

Wheatstone bridge.

Principle

Ohmic resistances, inductances and capacitances are determined in a Wheatstone bridge circuit operated on AC. Balancing is done aurally through headphones, using the high sensitivity of the human ear.

Tasks

Determination of

1. ohmic resistances.
2. inductances.
3. capacitances with the Wheatstone bridge, using bridge balancing.

What you can learn about

- Wheatstone bridge
- Inductive and capacitive reactance
- Ohmic resistance
- Impedance
- Kirchhoff's laws

Main articles

Digital Function Generator, USB, incl. Cobra4 Software	13654-99	1
Slide wire meas. bridge, simple	07182-00	1
Headphone, stereo	65974-00	1
Coil, 300 turns	06513-01	1
Coil, 600 turns	06514-01	1
Coil, 1200 turns	06515-01	1
Coil, 600 turns, short	06522-01	1

Related Experiment

Wheatstone bridge

P2410200

Slide wire measuring bridge, simple

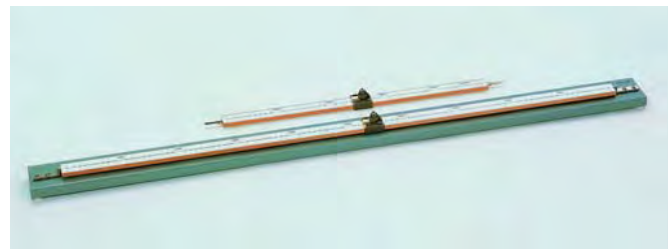

Function and Applications

To build a Wheatstone bridge.

Equipment and technical data

- Slide wire measuring bridge.
- On board with scale division in mm, cm, dm.
- Slider and board with 4 mm sockets.

07182-00

RLC circuit

P2440601

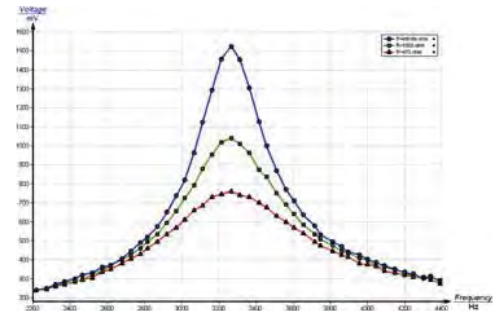
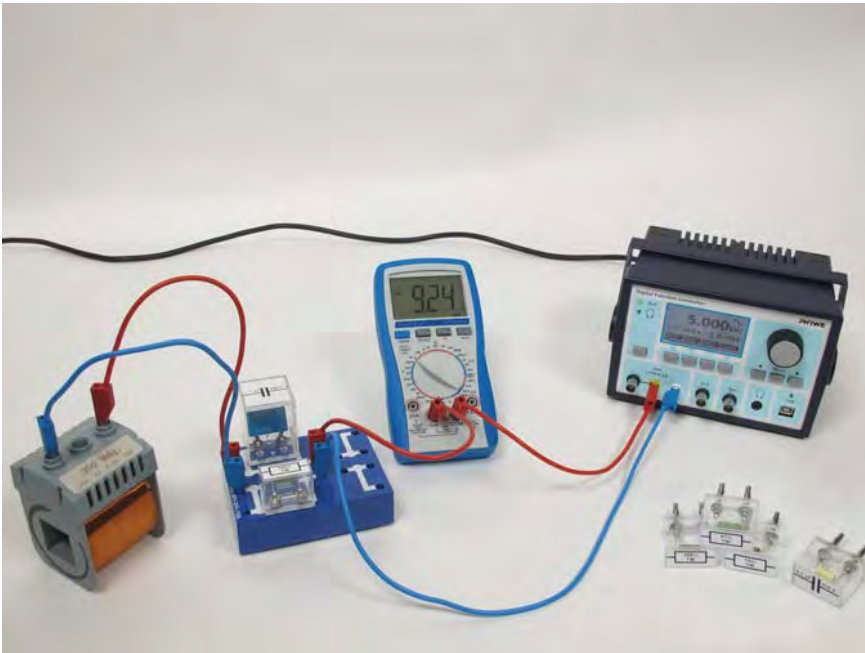

Total voltage as a function of frequency in the parallel tuned circuit. Curves recorded for different resistors (top down): $R = \infty \Omega$, 1000Ω , 470Ω .

Principle

The current and voltage of parallel and series-tuned circuits are investigated as a function of frequency. Q-factor and band-width are determined.

Tasks

Determination of the frequency performance of a

- Series-tuned circuit for
 1. voltage resonance without damping resistor,
 2. current resonance without damping resistor,
 3. current resonance with damping resistor.
- Parallel-tuned circuit for
 1. current resonance without parallel resistor,
 2. voltage resonance without parallel resistor,
 3. voltage resonance with parallel resistor.

What you can learn about

- Series-tuned circuit; Parallel-tuned circuit
- Resistance; Capacitance; Inductance
- Capacitor; Coil; Phase displacement
- Q factor; Band-width; Loss resistance; Damping

Main articles

Digital Function Generator, USB, incl. Cobra4 Software	13654-99	1
Coil, 300 turns	06513-01	1
Digital multimeter 2010	07128-00	1
Connection box	06030-23	1
Capacitor 1 microF/ 100V, G2	39113-01	1
Capacitor 100 nF/250V, G1	39105-18	1
Resistor 100 Ohm, 1W, G1	39104-63	1

Cobra4 Experiment - available 2013

RLC circuit (with Cobra4)

P2440660



P2440700 Rectifier circuits

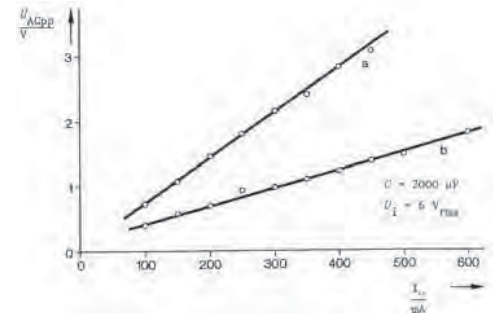
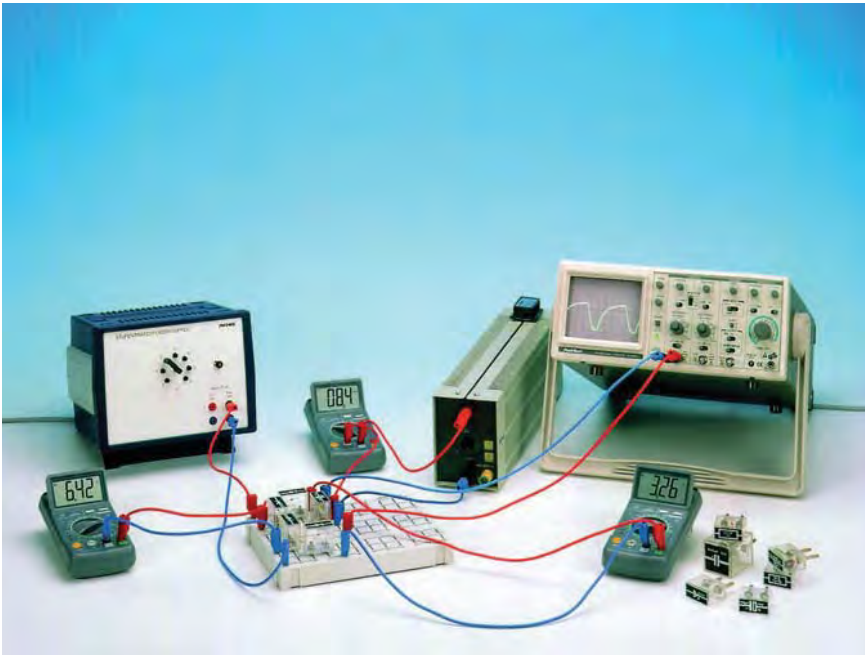

Ripple of the output voltage as a function of the charging current: a) half-wave rectifier, b) bridge rectifier.

Principle

The ripple of the output voltage of various rectifier circuits is measured as a function of the load current strength and the charging capacitance. The characteristics of a voltage stabilizer and of a multiplier are investigated.

Tasks

- Using the half-wave rectifier:
 1. To display the output voltage (without charging capacitor) on the oscilloscope.
 2. To measure the diode current I_D as a function of the output current strength I_o (with the charging capacitor).
 3. To measure the ripple component U_{ACpP} of the output voltage as a function of the output current ($C = \text{constant}$).
 4. To measure the ripple as a function of the capacitance ($I_o = \text{constant}$).
 5. To measure the output voltage U_o as a function of the input voltage U_i ($I_o = 0$).
- Using the bridge rectifier:
 1. To display the output voltage (without charging capacitor) on the oscilloscope.
 2. To measure the current through one diode, I_D , as a function of the output current I_o (with the charging capacitor).
 3. To measure the ripple of the output voltage as a function of the output current ($C = \text{constant}$).
 4. To measure the ripple as a function of the capacitance ($I_o = \text{constant}$).
 5. To measure the output voltage as a function of the input voltage.
- To measure the voltage at the charging capacitor, U_C , and the output voltage of a stabilised voltage source as a function of the input voltage U_i .

- To measure the output voltage of a voltage multiplier circuit as a function of the input voltage.

What you can learn about

- Half-wave rectifier
- Full-wave rectifier
- Graetz rectifier
- Diode and Zener diode
- Avalanche effect
- Charging capacitor
- Ripple
- r.m.s. value
- Internal resistance
- Smoothing factor
- Ripple voltage
- Voltage stabilisation
- Voltage doubling

Main articles

30 MHz digital storage oscilloscope with colour display, 2 x BNC cables $l = 75$ cm incl.	11462-99	1
Multitap transformer, 14 VAC/ 12 VDC, 5 A	13533-93	1
Rheostat, 330 Ohm , 1.0A	06116-02	1
Plug-in board,4mm plugs	06033-00	1
Digital multimeter 2010	07128-00	3
Electrolyte capacitor 2000 μ F/35V, G2	39113-08	1
Capacitor,electr.1mF/35V,G1	06049-09	1

RC filters

P2440801

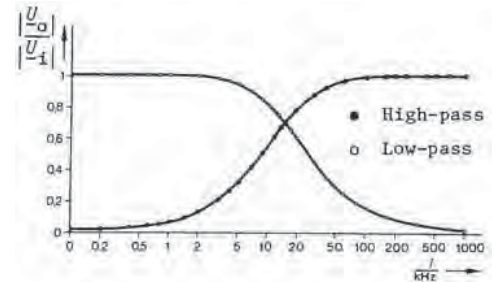
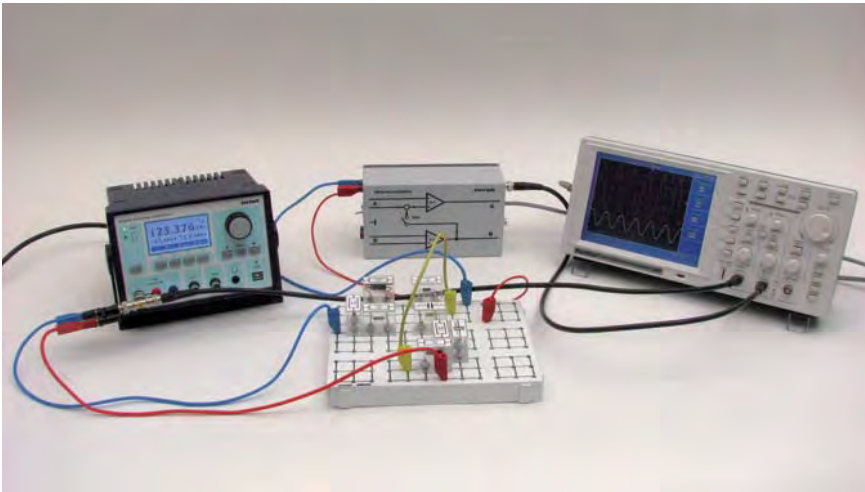

Example of a measured frequency response of the high- and low-pass filters.

Principle

Resistor-Capacitor (RC) circuits serve as filters for frequencies. The frequency response of the most commonly used RC filters is recorded by point-by-point measurements as well as the frequency sweep method, and displayed on the oscilloscope. The results are plotted and verified using the measure analysis software.

Tasks

- Record the frequency response of the output voltage of 1. a high-pass filter, 2. a low-pass filter, 3. a band-pass filter, 4. a Wien-Robinson bridge, 5. a parallel-T filter, point by point and to display the sweep on the oscilloscope. Investigate the step response of, 6. a differentiating network, 7. an integrating network.
- Analyse and verify the measurements using the measure analysis software.

What you can learn about

- High-pass; Low-pass
- Wien-Robinson bridge
- Parallel-T filters
- Differentiating network
- Integrating network
- Step response
- Square wave
- Transfer function

Main articles

Digital Function Generator, USB, incl. Cobra4 Software	13654-99	1
30 MHz digital storage oscilloscope with colour display, 2 x BNC cables l =75 cm incl.	11462-99	1
Difference amplifier	11444-93	1
Plug-in board,4mm plugs	06033-00	1
Resistor 500 Ohm 5%, 1W, G1	06057-50	1
Capacitor 10nF/ 250V, G1	39105-14	4
Resistor 1k0hm, 1W, G1	39104-19	5

Difference amplifier



Function and Applications

For the simultaneous potential-free measurement of two voltages when connected to the inputs of a two channel oscilloscope.

Benefits

- The high resistance difference inputs can be connected to any point of a circuit, without influencing the electrical behaviour of the circuit.
- Allows demonstration of the phase shift between voltage and current in alternating current circuits.
- Enables characteristics to be presented in the xy operation mode of an oscilloscope.
- Input voltages can be added.

Equipment and technical data

- Amplification $1 \pm 3\%$; Frequency range for UE 20 Vss 0.15 kHz, for UE 6 Vss 0.70 kHz, for UE 2 Vss 0.100 kHz
- Inputs A and B: connection 4-mm-pair of sockets
- Impedance 1 M /10 pF; Overload capacity mains voltage proof
- Outputs A and B: connection BNC-sockets;
- Internal resistance 100 Ohm; External resistance 10 kOhm
- Overload capacity short-circuit proof
- Mains supply 230 V, 50.60Hz; Casing dimensions (mm) 190×110×60

11444-93

P2440905 High-pass and low-pass filters with digital function generator

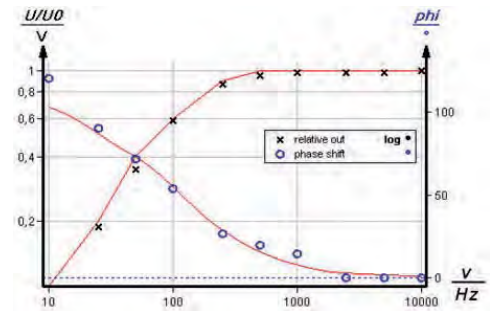
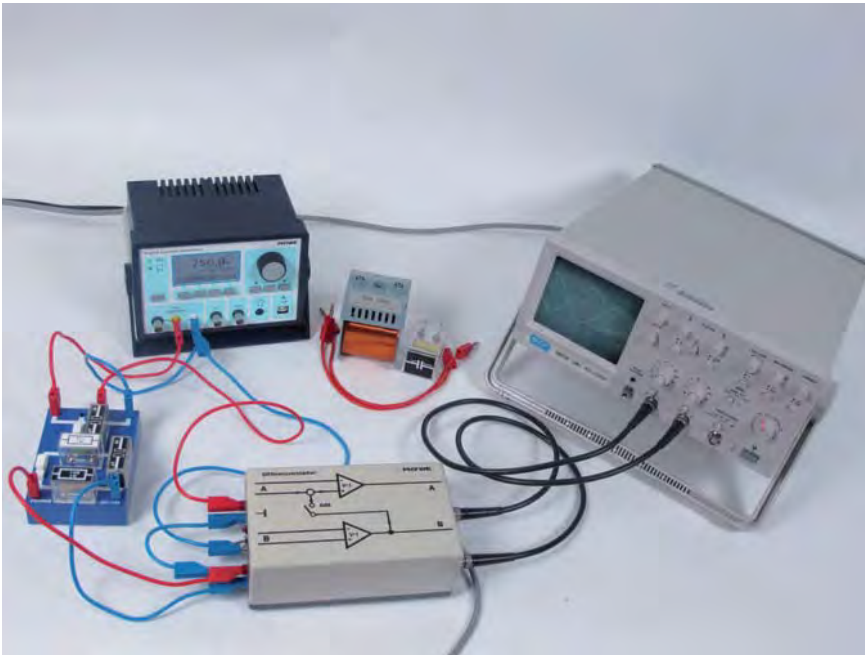

Voltage ratio (left axis) and phase displacement (right axis) of the double CR network as a function of frequency with $R_1=50 \Omega$, $R_2=1 \text{ k}\Omega$ and $C_1=25 \mu\text{F}$, $C_2=50 \mu\text{F}$.

Principle

A coil, a capacitor, an ohmic resistance and combinations of these components are investigated for their filter characteristics as a function of frequency. The phase displacement of the filters is determined also as a function of frequency.

Tasks

Determination of the ratio of output voltage to input voltage with the

1. RC/CR network,
2. RL/LR network,
3. CL/LC network,
4. Two CR networks connected in series.
5. Determination of the phase displacement with the RC/CR network.
6. Determination of the phase displacement with two CR networks connected in series.

What you can learn about

- Circuit; Resistance
- Capacitance; Inductance
- Capacitor; Coil
- Phase displacement
- Filter
- Kirchhoff's laws
- Bode diagram

Main articles		
Universal Counter	13601-99	1
30 MHz digital storage oscilloscope with colour display, 2 x BNC cables l =75 cm incl.	11462-99	1
Function generator, 0.1 Hz - 100 KHz	13652-93	1

Difference amplifier	11444-93	1
Coil, 300 turns	06513-01	1
Connection box	06030-23	2
Capacitor 1 microF/ 100V, G2	39113-01	1

Related Experiment

High-pass and low-pass filters with the FG module (with Cobra3)

P2440915

Cobra4 Experiment - available 2013

High-pass and low-pass filters (with Cobra4)

P2440960

You need more information? WEB@PHYWE
Just click www.phywe.com

Coupled resonant circuits

P2450201

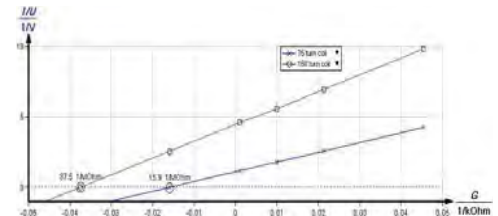
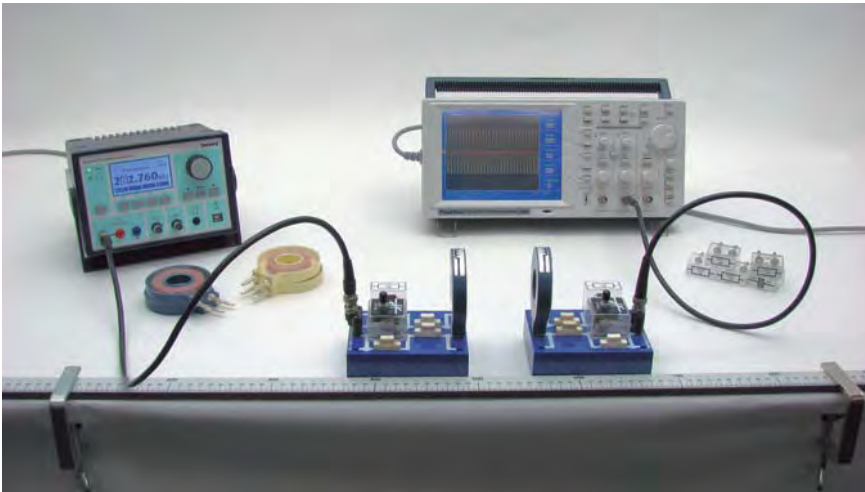

Reciprocal resonance voltage as a function of the additional conductance, used to determine G_p . 1. HF coil, 75 turns; 2. 150-turn coil.

Principle

The Q factor of oscillating circuits is determined from the band width and by the Pauli method. In inductively coupled circuits (band-pass filters) the coupling factor is determined as a function of the coil spacing.

Tasks

1. Determine the dissipation factor t and k and the quality factor Q from the band width of oscillating circuits.
2. Determine the dissipation factor and Q factor of oscillating circuits from the resonant frequency F , the capacitance C_{tot} and the parallel conductance G_p by the Pauli method.
3. Determine the coupling factor k and the band width of a band-pass filter as a function of the coil spacing s .
4. Analyse and verify the measurements using the measure analysis software.

What you can learn about

- Resonance
- Q factor
- Dissipation factor
- Bandwidth
- Critical or optimum coupling
- Characteristic impedance
- Pauli method
- Parallel conductance
- Band-pass filter
- Sweep

Main articles

Digital Function Generator, USB, incl. Cobra4 Software	13654-99	1
30 MHz digital storage oscilloscope with colour display, 2 x BNC cables $l = 75$ cm incl.	11462-99	1
HF-coil, 35 turns, 75 micro-H	06915-00	2
HF-coil, 50 turns, 150 micro-H	06916-00	2
HF-coil, 75 turns, 350 micro-H	06917-00	2
Coil, 150 turns, short	06520-01	1

Digital Function Generator, USB, incl. Cobra4 Software



Function and Applications

Digital signal generator for use as a programmable voltage source in practical or demonstration experiments, particularly in the disciplines of acoustics, electrical engineering and electronics

Benefits

- Can be used as universal stand-alone device or controlled via a USB interface
- Universally applicable thanks to broad, continually adjustable frequency range
- Usable as programmable voltage source via amplifier output
- Intuitive, menu-driven operation using control knob and function buttons, with help capability
- Illuminated monochrome graphic display for maximum visibility and readability
- Simple setting of voltage and frequency ramps in stand-alone mode
- Features $V = f(f)$ output for easy reading of frequency in the form of a voltage - ideal for measuring circuit response to frequency ramps using an oscilloscope

13654-99

P2450301 Forced oscillations of a nonlinear electrical series resonant circuit - chaotic oscillation (with Cobra3)

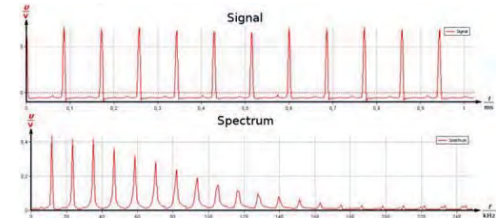
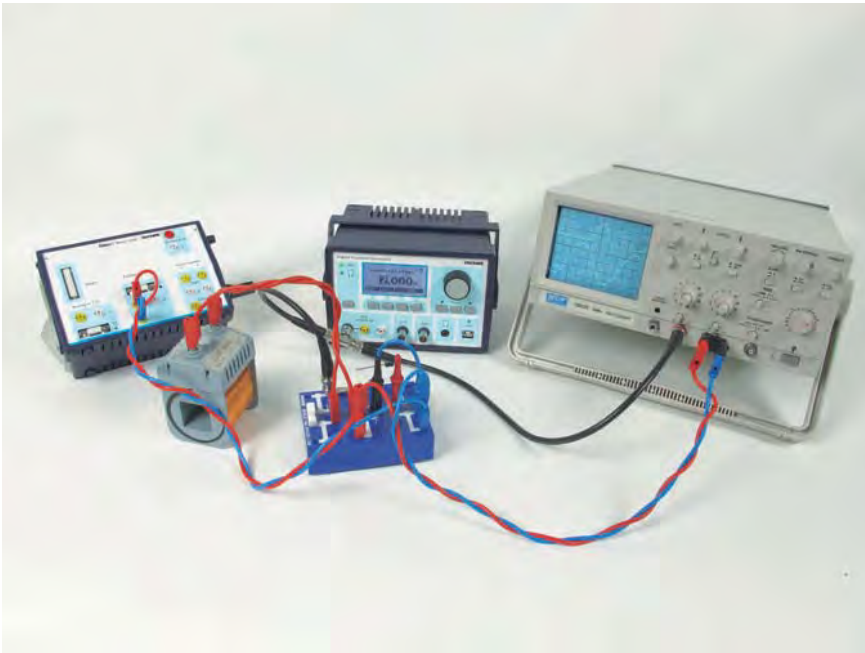

Voltage tapped off the diode at $U_{SS}=9V$. The circuit is oscillating chaotically.

Principle

A sinusoidal voltage is applied to a non-linear circuit with a silicon diode functioning as voltage-independent capacity.

The oscillating circuit, i.e. the occurrence of chaotic oscillatory behavior with increasing amplitude is studied.

Tasks

1. Study the oscillatory behavior of the non-linear circuit for an exciting signal with amplitudes between 0.1 and 15 V at frequency of 35 kHz.
2. Investigate the oscillatory image and the Fourier spectrum as functions of the excitation amplitude. Show that period multiples and regions of chaotic oscillatory amplitude occur with increasing amplitude.

What you can learn about

- Oscillating circuit; Forced oscillation
- Diode; Period multiples
- Fourier spectrum
- Chaotic oscillation

Main articles

Digital Function Generator, USB, incl. Cobra4 Software	13654-99	1
30 MHz digital storage oscilloscope with colour display, 2 x BNC cables l =75 cm incl.	11462-99	1
Cobra3 BASIC-UNIT, USB	12150-50	1
Coil, 1200 turns	06515-01	1
Power supply 12V / 2A	12151-99	1
Connection box	06030-23	1
Software Cobra3 - Fourier analysis	14514-61	1

Cobra4 Experiment - available 2013

Forced oscillations of a nonlinear electrical series resonant circuit - chaotic oscillation (with Cobra4)

P2450360





Renewable Energy

6.1	Preparatory Courses	142
6.2	Basic Principles	143
6.3	Heat	154
6.4	Solar Energy	159
6.5	Hydrogen Technology	162

09492-88 Demo Applied Sciences Set Renewable Energy ENT1

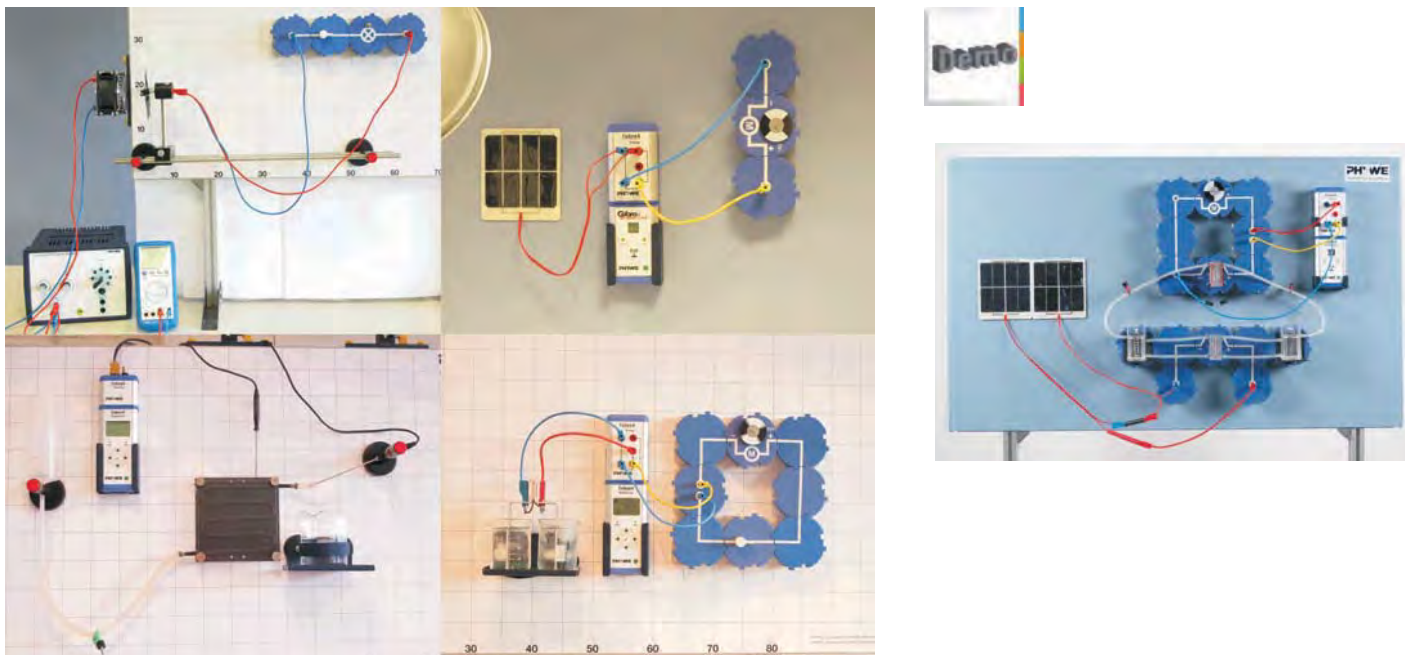

Function and Applications

Set 1 of 2 to perform more than 30 demo board experiments in the field of energy and sustainable energy sources:

conversion, storage, solar (voltaic, thermal), wind, water, geothermal energy, topics as the greenhouse effect and thermal insulation, hydrogen and fuel cell technology, concentrated solar power technology (CSP).

Benefits

- In combination with set 2 more than 30 experiments can be performed
- Complete set: easy set-up of the experiments to all relevant topics in the field of renewable energy
- Corresponding students kits available (13287-88, 13288-88): for flexible and competence-oriented science classes
- More than 90% of the experiments with computer based part: for modern and up-to-date sciences classes
- Matched to international curriculum: all subjects are covered
- High quality detailed descriptions with quick orientation guide, reference to everyday live and to corresponding student experiments
- Safe storage: durable, easy to store (stackable), quick control of completeness (foam insert)

Equipment and technical data

Selected parts:

- Solar Cells / Batteries
- Thermogenerator
- Electric Building Blocks
- Wind Generator / Turbine
- Solar Collector

Including storage boxes with insert foam, (mm): 130 × 410 × 545

Supplementary Set

Demo Applied Sciences Set Renewable Energy ENT2

09493-88

Literature

Demo advanced Applied Sciences manual Renewable Energy on the magnetic board

01157-02

Cobra4 extension Set

Cobra4 wireless, extension set for renewable energy: electric parameters, temperature

12608-88

Thermal and electrical conductivity of metals

P2350200

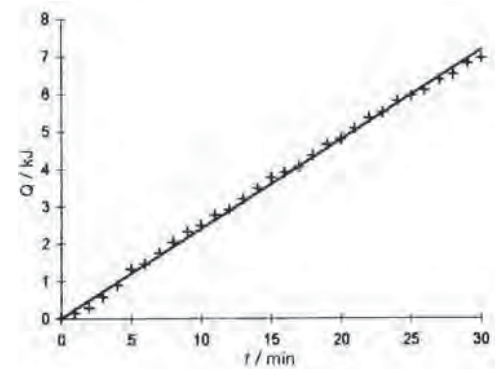

Diagram: Heat of surroundings over time.

Principle

The thermal conductivity of copper and aluminium is determined in a constant temperature gradient from the calorimetrically measured heat flow.

The electrical conductivity of copper and aluminium is determined, and the Wiedmann-Franz law is tested.

Tasks

1. Determine the heat capacity of the calorimeter in a mixture experiment as a preliminary test.
2. Measure the calefaction of water at a temperature of 0 °C in a calorimeter due to the action of the ambient temperature as a function of time.
3. To begin with, establish a constant temperature gradient in a metal rod with the use of two heat reservoirs (boiling water and ice water). After removing the pieces of ice, measure the calefaction of the cold water as a function of time and determine the thermal conductivity of the metal rod.
4. Determine the electrical conductivity of copper and aluminium by recording a current-voltage characteristic line.
5. Test of the Wiedmann-Franz law.

What you can learn about

- Electrical conductivity
- Wiedmann-Franz law
- Lorenz number
- Diffusion
- Temperature gradient
- Heat transport
- Specific heat
- Four-point measurement

Main articles

Temperature meter digital, 4-2	13617-93	1
Universal measuring amplifier	13626-93	1
Multitap transformer, 14 VAC/ 12 VDC, 5 A	13533-93	1
Rheostat, 10 Ohm , 5.7A	06110-02	1
Heat conductivity rod, Cu	04518-11	1
Magnetic stirrer Mini / MST	47334-93	1
Temp. probe, immersion type, Pt100, stainless steel, -20...+300°C	11759-01	1

You need more information?
Just click www.phywe.com

WEB@ PHYWE



P3010701 Thermal conductivity of gases

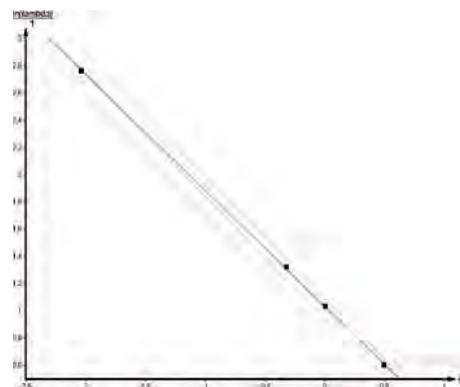
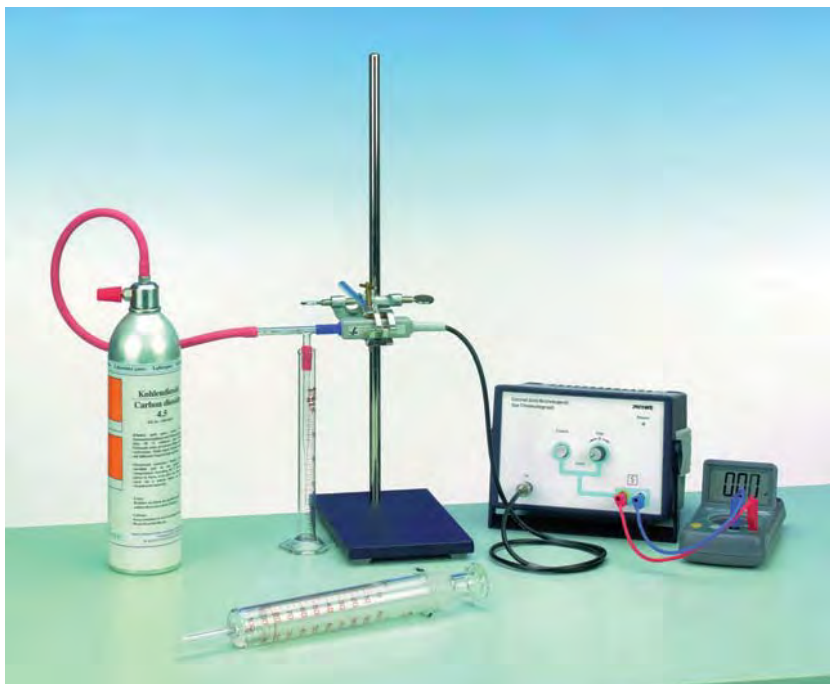

Calibration curve for the determination of coefficients of thermal conductivity.

Principle

The thermal conductivity of different gases are measured with a gas-chromatographic thermal conductivity detector under stationary conditions. The electrical measurement parameter, which is obtained as a voltage signal in the experimental setup, is proportional to the logarithm of the coefficient of thermal conductivity.

Tasks

1. Measure the thermal conductivity of different gases.
2. Prepare a calibration curve by making a semi-logarithmic plot of the tabulated thermal-conductivity values against the measurement signals.

What you can learn about:

- Thermal conductivity
- Coefficient of thermal conductivity
- Thermal-conductivity detector
- Gas chromatography

Main articles

Control unit gas chromatograph	36670-99	1
Multirange meter with amplifier	07042-00	1
Steel cylinder helium, 2 l, filled	41776-00	1
Mesure probe for gas chromatograph, BNC contact	36670-10	1
Reducing valve for CO ₂ / He	33481-00	1
Table stand for 2 l steel cylinders	41774-00	1
Silicone oil 500 ml	31849-50	1

Control unit gas chromatograph



Function and Applications

For voltage supply and for equalisation of the measure probe for gas chromatograph.

Equipment and technical data

- Zero balance: Push button for rough balance, potentiometer for fine balance
- Input: BNC sockets for probe
- Output: 4-mm sockets for display device (e.g. interface)
- Dimensions (mm): 225 × 113 × 125
- Voltage supply: 110...230 V AC

36670-99

Heat capacity of gases

P2320201

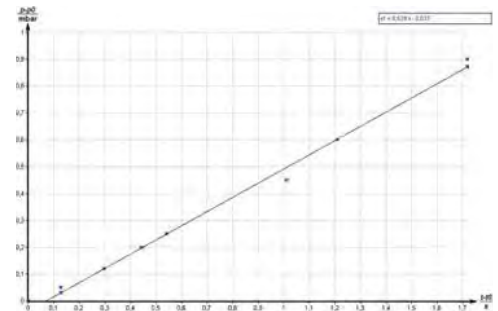
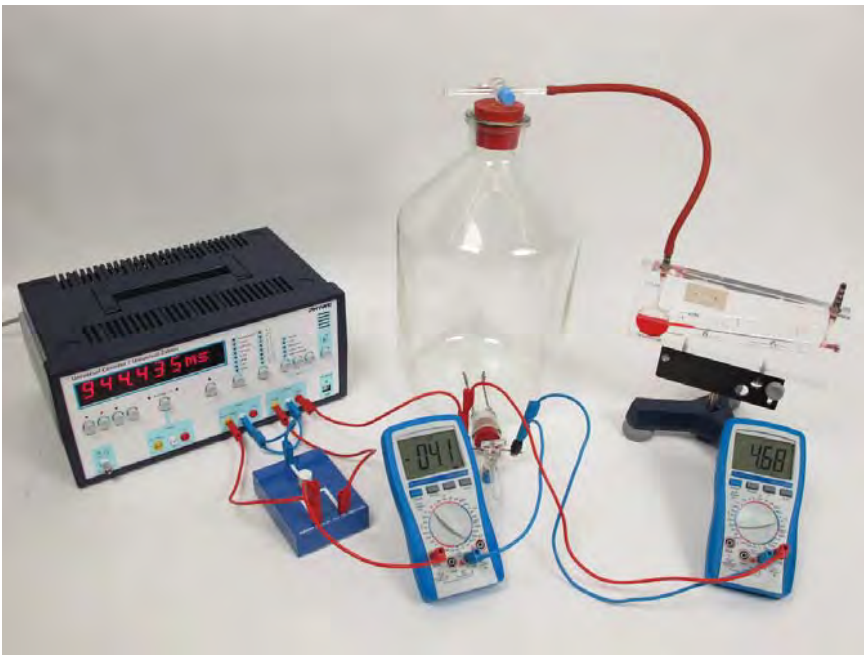

Pressure change ρ as a function of the heat-up time t . $U = 4.59 \text{ V}$, $I = 0.43 \text{ A}$.

Principle

Heat is added to a gas in a glass vessel by an electric heater which is switched on briefly. The temperature increase results in a pressure increase, which is measured with a manometer. Under isobaric conditions a temperature increase results in a volume dilatation, which can be read from a gas syringe. The molar heat capacities C_V and C_p are calculated from the pressure or volume change.

Task

Determine the molar heat capacities of air at constant volume C_V and at constant pressure C_p .

What you can learn about

- Equation of state for ideal gases
- First law of thermodynamics
- Universal gas constant
- Degree of freedom
- Mole volumes
- Isobars
- Isotherms
- Isochores and adiabatic changes of state

Main articles

Universal Counter	13601-99	1
Precision manometer	03091-00	1
Weather station, wireless	04854-00	1
Mariotte flask, 10 l	02629-00	1
Tripod base PHYWE	02002-55	1
Digital multimeter 2010	07128-00	2
Two-way switch, single pole	06030-00	1

Related Experiment

Specific heat capacity of water (with Cobra4)

P1043960

Cobra4 Experiments - available 2013

Heat capacity of metals (with Cobra4)

P2330160

Heat capacity of gases (with Cobra4)

P2320260

P2330101 Heat capacity of metals

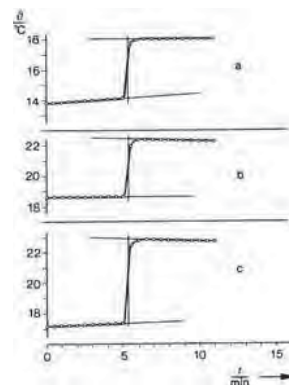

Temperature as a function of time in the method of mixtures experiment a) steel, b) brass, c) aluminium.

Principle

Heated specimens are placed in a calorimeter filled with water at low temperature. The heat capacity of the specimen is determined from the rise in the temperature of the water.

Tasks

1. To determine the specific heat capacity of aluminium, iron and brass.
2. To verify Dulong Petit's law with the results of these experiments.

What you can learn about

- Mixture temperature
- Boiling point
- Dulong Petit's law
- Lattice vibration
- Internal energy
- Debye temperature

Main articles

Calorimeter, 500 ml	04401-00	1
Aneroid barometer	03097-00	1
Butane burner, Labogaz 206 type	32178-00	1
Thermometer -10...+50 °C	38034-00	1
Stopwatch, digital, 1/100 s	03071-01	1
Metal bodies, set of 3	04406-00	4
Set of Precision Balance Sartorius TE 601 and measure software balances, 230V	48837-88	1

Cobra4 Experiment - available 2013

Heat capacity of metals (with Cobra4)

P2330160

Calorimeter, 500 ml



Function and Applications

For determination of the specific heat capacities of solid state bodies and liquids.

Equipment and technical data

- Calorimeter, 500 ml.
- Aluminium vessel in container with heat insulation.
- Cover with stirrer. 4 mm sockets for power supply.
- Spiral heating resistance: approx. 2.4 Ohm.
- Diameter: 134 mm. Height: 160 mm.

04401-00

Mechanical equivalent of heat

P2330200

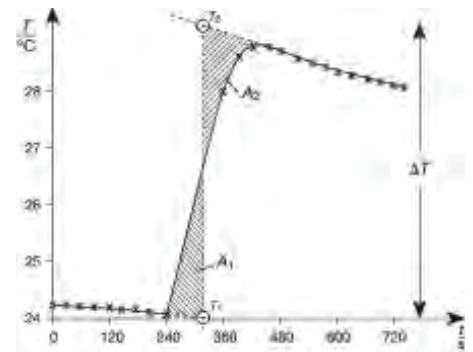

Temperature-time diagram for a measurement example.

Principle

In this experiment, a metal test body is rotated and heated by the friction due to a tensed band of synthetic material. The mechanical equivalent of heat for problem 1 is determined from the defined mechanical work and from the thermal energy increase deduced from the increase of temperature. Assuming the equivalence of mechanical work and heat, the specific thermal capacity of aluminium and brass is determined.

Tasks

1. Determination of the mechanical equivalent of heat.
2. Determination of the specific thermal capacity of aluminum and brass.

What you can learn about

- Mechanical equivalent of heat
- Mechanical work
- Thermal energy
- Thermal capacity
- First law of thermodynamics
- Specific thermal capacity

Main articles

Mechanical equiv.of heat app.	04440-00	1
Friction cylinder CuZn, m 1.28 kg	04441-02	1
Spring balance 100 N	03060-04	1
Friction cylinder Al, m 0.39 kg	04441-03	1
Spring balance 10 N	03060-03	1
Bench clamp PHYWE	02010-00	1
Commercial weight, 2000 g	44096-78	1

Cobra4 Experiment - available 2013

Mechanical equivalent of heat (with Cobra4)

P2330260



P3011160 Gay-Lussac's law (with Cobra4)

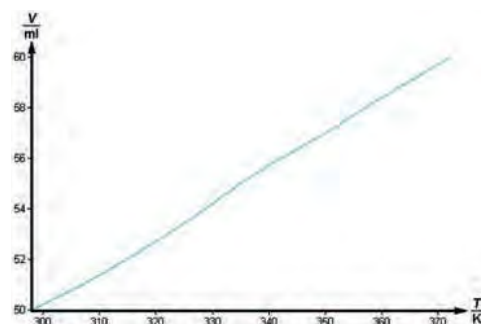

Dependence of the volume on the temperature under isobaric conditions.

Principle

The state of a gas is determined by temperature, pressure and amount of substance. For the limiting case of ideal gases, these state variables are linked via the ideal gas law. For a change of state under isobaric conditions this equation converts Gay-Lussac's first law.

Tasks

1. Experimentally investigate the validity of Gay-Lussac's law for a constant amount of gas (air).
2. Calculate the universal gas constant and the thermal coefficient of expansion from the relationship obtained.

What you can learn about

- Pressure; Temperature; Volume
- Coefficient of thermal expansion
- Ideal gas law; Universal gas constant
- Gay-Lussac's law

Main articles

Set Gas laws with glass jacket system and Cobra4	43020-00	1
Cobra4 Remote-Link	12602-00	1

Related Experiments

Amontons' law (with Cobra4)

P3011260

Boyle's law (with Cobra4)

P3011360

Set Gas laws with glass jacket system and Cobra4



Function and Applications

Complete device compilation for a comfortable way to derive the ideal gas laws experimentally with help of the Cobra4 Sensor-Unit Thermodynamics and the glass jacket system.

Equipment and technical data

The set consists of:

- 1 Cobra4 Wireless Manager. 1 Cobra4 Wireless-Link
- 1 Cobra4 Sensor-Unit Thermodynamics, pressure absolute 2 bar and 2 x temperature
- 1 Software measure Cobra4, single user and school licence
- 1 Glass jacket; 1 Gas syringe 100 ml
- 1 Heater for Glass jacket
- 1 Immersion probe NiCr-Ni, -50...1000 °C

43020-00

Determination of the heating value of fuel oil and of the calorific value of olive oil

P3021701

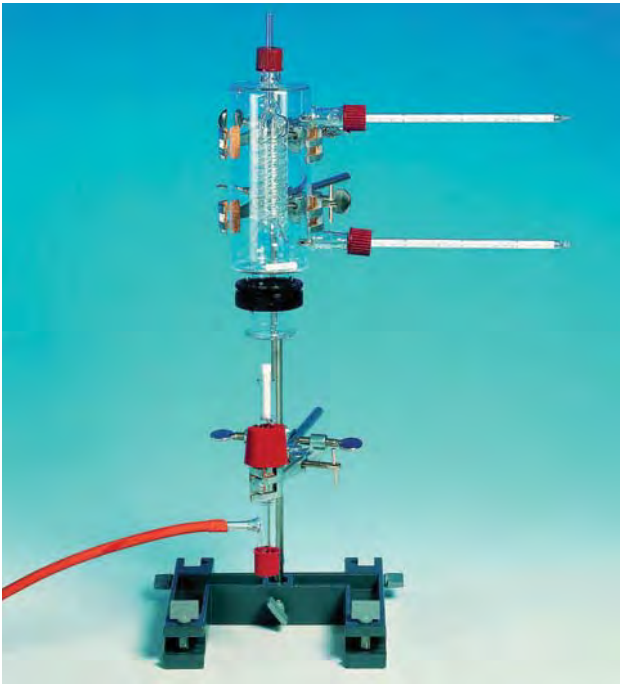

$$H = \frac{(m_w \cdot c_w + C_{\text{cal}}) \cdot \Delta T}{m}$$

Equation to calculate the calorific value (of fuels) and the gross calorific value (of food-stuffs).

Principle

The heat of reaction generated during the complete combustion of 1000 g of solid or liquid fuel is known as the calorific value H . In the case of complete combustion of nutritional fats, the gross calorific value can also be determined. In order to ensure complete combustion, the reaction takes place under oxygen. The heat generated during the combustion of a specific amount of fuel is absorbed by a glass jacket calorimeter of known heat capacity. The calorific value of the test substance can be calculated from the temperature increase in the calorimeter.

Task

Determine the calorific value of heating oil and the gross calorific value of olive oil.

What you can learn about

- Heat of reaction
- Heat of combustion
- Enthalpy of combustion
- First law of thermodynamics

Main articles

Glass jacket	02615-00	1
Steel cylinder oxygen, 2 l, filled	41778-00	1
Calorimeter insert for glass jacket	02615-01	1
Reducing valve for oxygen	33482-00	1
Table stand for 2 l steel cylinders	41774-00	1
Set of Precision Balance Sartorius CPA 623S and measure software, 230 V	49224-88	1

Calorimeter insert for glass jacket



Function and Applications

Calorimeter insert for glass jacket.

Benefits

- It can determine calorific values, heat of combustion and enthalpies of gaseous, liquid and solid substances.
- Combustion chamber with a circular cross section, rotating double helix as a heat exchanger

Equipment and technical data

- Total length: 280 mm
- Combustion chamber length: 90 mm
- Outer combustion chamber: 36 mm
- Length of the approach pipe: 70 mm
- OD approach pipe: 8 mm

02615-01

P3021401 Determination of the enthalpy of combustion with a calorimetric bomb

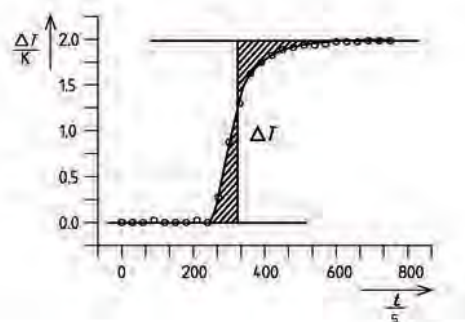

Determining the corrected temperature difference.

Principle

The bomb calorimeter is used to completely burn substances in an excess of oxygen. The heat of combustion released is absorbed by the calorimetric vessel in which the bomb is immersed, and results in a temperature increase ΔT . The heat capacity of the system is first determined by adding a defined amount of heat from the combustion of benzoic acid. The combustion of the naphthalene is subsequently performed under the same conditions.

Tasks

1. Determine the enthalpy of combustion of naphthalene using a bomb calorimeter.
2. Calculate the enthalpy of formation of naphthalene from the enthalpy of combustion using Hess' law.

What you can learn about

- First law of thermodynamics
- Hess' law of constant heat summation
- Enthalpy of combustion
- Enthalpy of formation
- Heat capacity

Main articles

Calorimetric bomb	04403-00	1
Temperature meter digital, 4-2	13617-93	1
Power supply, universal	13500-93	1
Magnetic stirrer MR Hei-Standard	35750-93	1
Calorimeter, transparent, volume appr. 1200 ml	04402-00	1
Set of Precision Balance Sartorius CPA 6202S and measure software, 230 V	49226-88	1
Set of Precision Balance Sartorius CPA 623S and measure software, 230 V	49224-88	1

Calorimetric bomb



Function and Applications

Calorimetric bomb for the quantitative determination of combustion heat of liquid and solid organic substances under high oxygen pressure.

Equipment and technical data

- Stainless steel body
- Contents approx. 120 ml
- Stainless steel lid with valve
- Oxygen filling connection
- Max. oxygen pressure 25 bar
- Ignition wire

04403-00

Characteristic curves of semiconductors (with Cobra4)

P2410960

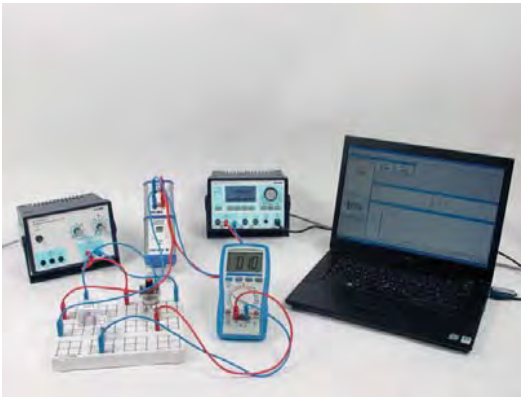

Principle

Determine the current strength flowing through a semi-conducting diode. Determine the collector current with the collector voltage for various values of the base current intensity.

Tasks

1. To investigate the dependence of the current strength flowing through a semi-conducting diode.
2. To determine the variations of the collector current with the collector voltage for various values of the base current intensity.

For more details refer to page 111.

Temperature dependance of different resistors and diodes (with Cobra4)

P2410460

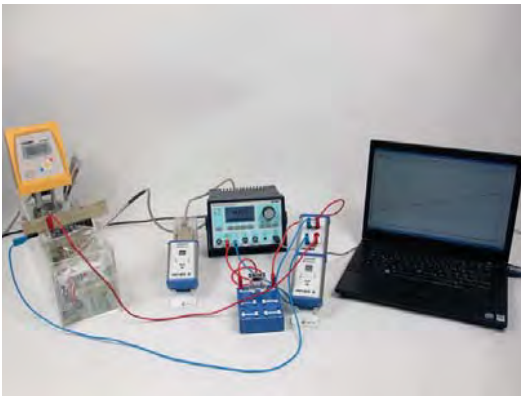

Principle

The temperature dependence of an electrical parameter (e.g. resistance, conducting-state voltage, blocking voltage) of different components is determined. To do this, the immersion probe set is immersed in a water bath and the resistance is measured at regular temperature intervals.

Tasks

1. Measurement of the temperature dependence of the resistance of different electrical components.
2. Measurement of the temperature dependence of the conducting state voltage of semiconducting diodes.

For more details refer to pages 53, 112.

Hall effect in p-germanium (with Cobra3)

P2530111

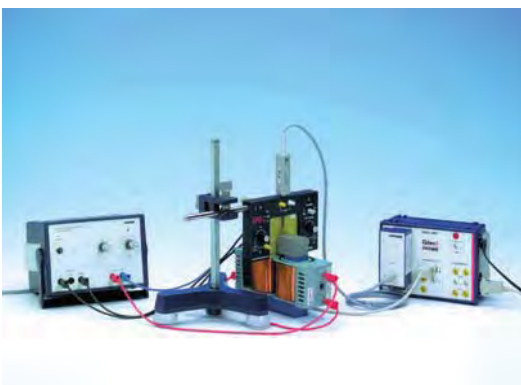

Principle

The resistivity and Hall voltage of a rectangular germanium sample are measured as a function of temperature and magnetic field. The band spacing, the specific conductivity, the type of charge carrier and the mobility of the charge carriers are determined from the measurements.

Task

The Hall voltage is measured at room temperature and constant magnetic field as a function of the control current and plotted on a graph (measurement without compensation for defect voltage).

For more details refer to www.phywe.com

Transformer

P2440100



For more details refer to page 123.

Principle

An alternating voltage is applied to one of two coils (primary coil) which are located on a common iron core. The voltage induced in the second coil (secondary coil) and the current flowing in it are investigated as functions of the number of turns in the coils and of the current flowing in the primary coil.

Tasks

The secondary voltage on the open circuited transformer is determined as a function

1. Of the number of turns in the primary coil.
2. Of the number of turns in the secondary coil.
3. Of the primary voltage.

Charging curve of a capacitor / charging and discharging of a capacitor

P2420201



For more details refer to page 114.

Principle

A capacitor is charged by way of a resistor. The current is measured as a function of time and the effects of capacitance, resistance and the voltage applied are determined.

Tasks

To measure the charging current over time:

1. using different capacitance values C , with constant voltage U and constant resistance R
2. using different resistance values (C and U constant)
3. using different voltages (R and C constant).

Switch-on behaviour of a capacitor and an inductance with the FG module (with Cobra3)

P2420715



Principle

To measure the course of current strength and voltage in a capacitance/inductivity in the instant of switching on. The capacitance/inductivity is determined from the measurement curve.

Tasks

1. To measure the course of current strength and voltage in a capacitance in the instant of switching on. The capacitance is determined from the measurement curve.
2. To measure the course of current strength and voltage in inductivity in the instant of switching on. The inductivity is determined from the measurement curve.

For more details refer to page 115.

Dielectric constant of different materials

P2420600



Principle

The electric constant is determined by measuring the charge of a plate capacitor to which a voltage is applied. The dielectric constant is determined in the same way, with plastic or glass filling the space between the plates.

Tasks

1. The relation between charge Q and voltage U is to be measured using a plate capacitor.
2. The electric constant is to be determined from the relation measured under point 1.

For more details refer to pages 57, 113.

Electric fields and potentials in the plate capacitor

P2420100



Principle

A uniform electric field E is produced between the charged plates of a plate capacitor. The strength of the field is determined with the electric field strength meter, as a function of the plate spacing d and the voltage U . The potential ϕ within the field is measured with a potential measuring probe.

Tasks

1. The relationship between voltage and electric field strength is investigated, with constant plate spacing.
2. The relationship between electric field strength and plate spacing is investigated, with constant voltage.

For more details refer to www.phywe.com

Nernst equation (with Cobra4)

P3060962



NEW

C4

Principle

The Nernst equation expresses how the electrical potential of an electrode in contact with a solution of ions depends upon the concentrations (more accurately, activities) of those ions. The equation may be experimentally verified using an electrochemical cell formed from an inert indicator electrode coupled with a convenient reference electrode. The potential of the indicator electrode, and hence the e.m.f. of the cell, is monitored as the ionic composition of the electrolyte solution is changed.

For more details refer to page 127.

P2360360 Heat insulation / heat conduction

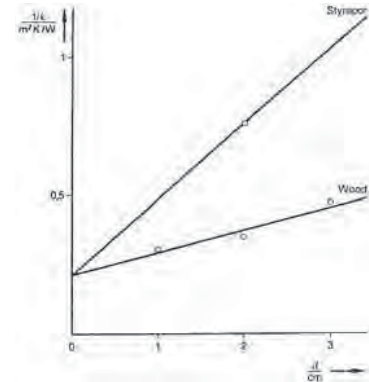

Heat transition resistance $1/k$ as a function of the wall thickness d .

Principle

A model house with replaceable side walls is used for determining the heat transition coefficients (k values) of various walls and windows and for establishing the heat conductivities of different materials. For this purpose the temperatures on the inside and outside of the walls are measured at a constant interior and outer air temperature (in the steady state).

With a multilayer wall structure the temperature difference over a layer is proportional to the particular thermal transmission resistance. The thermal capacity of the wall material affects the wall temperatures during heating up and temporary exposure to solar radiation.

Tasks

1. Measurement and interpretation of water temperatures during the heating up and during temporary external illumination of the walls.
2. Determination of the heat conductivities of wood and polystyrene.
3. Determination of the k values of ordinary glass and insulating glass windows and of wooden walls of different thicknesses, and of walls with wood, polystyrene or cavity layers.

What you can learn about

- Heat transition; Heat transfer; Heat conductivity
- Thermal radiation
- Hothouse effect
- Thermal capacity
- Temperature amplitude attenuation

Main articles

High insulation house	04507-93	1
-----------------------	----------	---

Thermal regulation for high insulation house	04506-93	1
Cobra4 Mobile-Link set, incl. rechargeable batteries, SD memory card, USB cable and software "measure"	12620-55	2
Cobra4 Sensor-Unit 2 x Temperature, NiCr-Ni	12641-00	2
Thermocouple NiCr-Ni, -50...500°C	13615-02	4

High insulation house

Function and Applications

Device for quantitative experiments with thermal insulation.

Equipment and technical data

- The high insulation house consists of a thermally insulated base rack with removable lid, measuring walls, exterior insulation and heating.
- Basic rack: ground insulated through a 5 cm thick Styrofoam plate.
- Side walls with square apertures (210 mm × 210 mm).
- The measuring walls are set in from the inside and pressed by two screws against the aperture gasket.
- Each of the exterior walls carry a profile and a small eccentric plate to hold supplementary insulating material.
- Every angle pillar has a hole to introduce temperature probes.
- The hole is sealed off with foam material.
- Lid insulated by a 5 cm thick Styrofoam plate, fixed to the angle pillars of the base rack with 4 knurled screws which cannot be lost.
- Casing dimensions (mm): 400 × 400 × 400 .

04507-93

Electric compression heat pump

P2360200

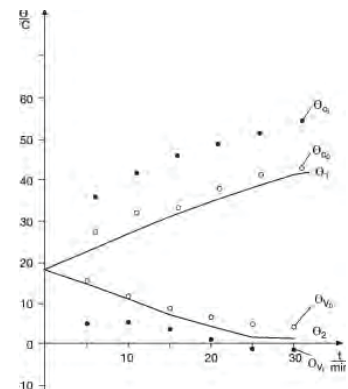

Temperatures at the inlet and outlet of the vaporiser V_i , V_o and condenser C_i , C_o as a function of the operating time; continuous curves: temperature in water reservoirs.

Principle

Pressures and temperatures in the circulation of the heat electrical compression heat pump are measured as a function of time when it is operated as a water-water heat pump.

The energy taken up and released is calculated from the heating and cooling of the two water baths.

When it is operated as an air-water heat pump, the coefficient of performance at different vaporiser temperatures is determined.

Tasks

- Water heat pump:** To measure pressure and temperature in the circuit and in the water reservoirs on the condenser side and the vaporiser side alternately. To calculate energy taken up and released, also the volume concentration in the circuit and the volumetric efficiency of the compressor.
- Air-water heat pump:** To measure vaporiser temperature and water bath temperature on the condenser side under different operating conditions on the vaporiser side,
 - with stream of cold air
 - with stream of hot air
 - without blower.

If a power meter is available, the electric power consumed by the compressor can be determined with it and the coefficient of performance calculated.

What you can learn about

- Refrigerator; Compressor
- Restrictor valve; Cycle
- Vaporization; Condensation
- Vapour pressure; Vaporisation enthalpy

Main articles

Heat pump, compressor principle	04370-88	1
Work and power meter	13715-93	1
Tripod base PHYWE	02002-55	1
Hot/cold air blower, 1800 W	04030-93	1

Work and power meter**Function and Applications**

For AC and DC circuits.

Equipment and technical data

- Two 4-digit, 20 mm LED-displays
- Display 1 for real and apparent power, current, voltage, phase difference and frequency
- Display 2 for energy and time; Selector for serial display of all units
- LED-Status-display and automatic range selection
- Power: max. 2400 W; Resolution: max. 0.001 W
- Voltage: 0-30V AC/DC, 0-240; Veff- Current: 0...10A AC/DC
- Phasen difference: 0...+/- 90 degree; Frequency: 0...10000 Hz
- Energy: max. 9999 Wh or Ws; Resolution: max. 0.001 Ws
- Analog output for all units of disp. 1; Mains: 110/230V, 50/60Hz
- Shock-resistant plastic housing with carry handle and base

13715-93

P2410800 Peltier heat pump

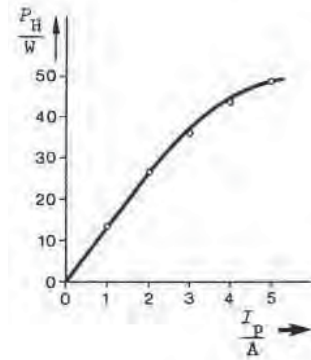

Pump cooling capacity as a function of the operating current.

Principle

The (cooling capacity) heating capacity and efficiency rating of a Peltier heat pump are determined under different operating conditions.

Tasks

1. To determine the cooling capacity P_c the pump as a function of the current and to calculate the efficiency rating η_c at maximum output.
2. To determine the heating capacity P_w of the pump and its efficiency rating η_w at constant current and constant temperature on the cold side.
3. To determine P_w , η_w and P_c , η_c from the relationship between temperature and time on the hot and cold sides.
4. To investigate the temperature behaviour when the pump is used for cooling, with the hot side air-cooled.

What you can learn about

- Peltier effect; Heat pipe; Thermoelectric e. m. f.
- Peltier coefficient; Cooling capacity; Heating capacity
- Efficiency rating; Thomson coefficient; Seebeck coefficient
- Thomson equations; Heat conduction; Convection
- Forced cooling; Joule effect

Main articles

Thermogenerator with 2 water baths	04366-00	1
Power supply, universal	13500-93	1
Rheostat, 33 Ohm, 3.1A	06112-02	1
Flow-through heat exchanger	04366-01	1
Air cooler	04366-02	1

Thermogenerator with 2 water baths



Function and Applications

To commute thermal energy into electrical energy directly and for operation as heat pump. Also been used to demonstrate the Seebeck effect and the Peltier effect.

Equipment and technical data

- Generator block consisting of two nickel coated copper plates with hole for thermometer, between these, p- and n-conducting silicon thermocouples, connected thermally parallel and electrically in series.
- Two water containers with open sides, which are used as heat reservoirs, are screwed to the generator block. They can be exchanged for flowthrough heat exchanger or air cooler.
- Standard accessories: 2 open water containers (brass, nickel coated); 2 rubber gaskets; 2 clamping jaws and 4 knurled screws.

04366-00

Semiconductor thermogenerator - Seebeck effect

P2410700

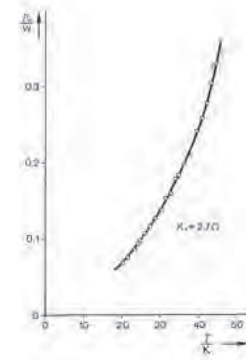

Electrical power generated as a function of the temperature difference.

Principle

In a semi-conductor thermogenerator, the no-load voltage and the short-circuit current are measured as a function of the temperature difference. The internal resistance, the Seebeck coefficient and the efficiency are determined.

Tasks

1. To measure no-load voltage U_0 and short-circuit current I_s at different temperature differences and to determine the Seebeck coefficient.
2. To measure current and voltage at a constant temperature difference but with different load resistors, and to determine the internal resistance R_i from the measured values.
3. To determine the efficiency of energy conversion, from the quantity of heat consumed and the electrical energy produced per unit time.

What you can learn about

- Seebeck effect (thermoelectric effect)
- Thermoelectric e.m.f.
- Efficiency
- Peltier coefficient
- Thomson coefficient
- Seebeck coefficient
- Direct energy conversion
- Thomson equations

Main articles

Thermogenerator with 2 water baths	04366-00	1
Immersion thermostat Alpha A, 230 V	08493-93	1
Rheostat, 33 Ohm , 3.1A	06112-02	1
Voltmeter, 0.3-300VDC, 10-300VAC /	07035-00	1

Bath for thermostat, Makrolon	08487-02	1
Ammeter 1/5 A DC	07038-00	1
Flow-through heat exchanger	04366-01	2

Flow-through heat exchanger**Function and Applications**

To generate a constant temperature with running water.

Equipment and technical data

- Nickel coated brass with tubing olives; is fastened to the generator block of the thermo generator in place of a water container.
- When using the thermo generator as a Peltier heat pump to generate low temperatures (about $-15\text{ }^{\circ}\text{C}$), the warm side is cooled.
- Dimensions (mm): $28 \times 70 \times 94$.

04366-01

P2360401 Stirling engine with an oscilloscope

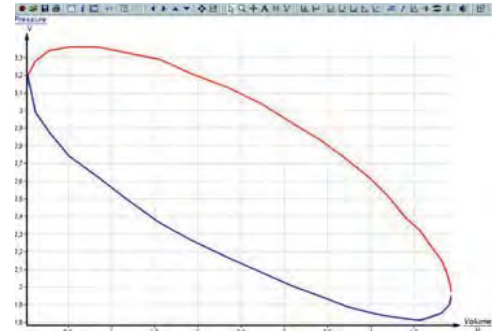
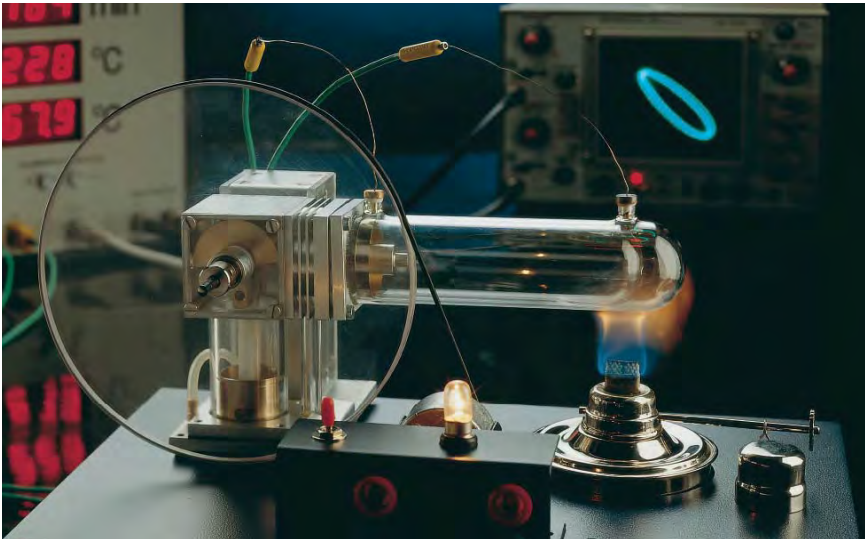

Pressure as a function of volume for the Stirling process.

Principle

The Stirling engine is submitted to a load by means of an adjustable torquemeter, or by a coupled generator. Rotation frequency and temperature changes of the Stirling engine are observed. Effective mechanical energy and power, as well as effective electrical power, are assessed as a function of rotation frequency. The amount of energy converted to work per cycle can be determined with the assistance of the pV diagram. The efficiency of the Stirling engine can be estimated.

Tasks

1. Determination of the burner's thermal efficiency.
2. Calibration of the sensor unit.
3. Calculation of the total energy produced by the engine through determination of the cycle area on the oscilloscope screen, using transparent paper and coordinate paper.
4. Assessment of the mechanical work per revolution, and calculation of the mechanical power output as a function of the rotation frequency, with the assistance of the torque meter.
5. Assessment of the electric power output as a function of the rotation frequency.
6. Efficiency assessment.

What you can learn about

- First and second law of thermodynamics; Reversible cycles; Isochoric and isothermal changes
- Gas laws; Efficiency; Stirling engine; Conversion of heat; Thermal pump

Main articles

Meter for Stirling engine, pVnT	04371-97	1
Stirling engine transparent	04372-00	1
30 MHz digital storage oscilloscope with colour display, 2 x BNC cables l = 75 cm incl.	11462-99	1
Sensor unit pVn for Stirling engine	04371-00	1
Torque meter	04372-02	1

Motor/ generator unit	04372-01	1
Rheostat, 330 Ohm , 1.0A	06116-02	1

Cobra4 Experiment - available 2013

Stirling engine (with Cobra4)

P2360460

Meter for Stirling engine, pVnT



Function and Applications

To display temperature and number of revolutions per minute and for the output of analogue voltages for Stirling motor pressure and volume.

04371-97

Stefan-Boltzmann's law of radiation with an amplifier

P2350101

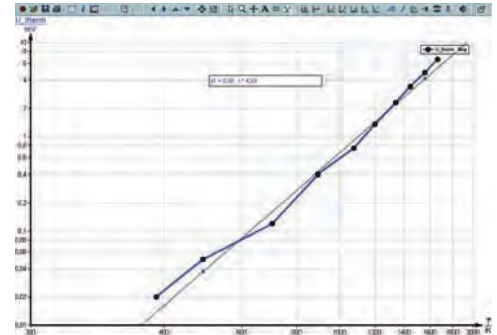

Thermoelectric e. m. f. of thermopile as a function of the filament's absolute temperature.

Principle

According to Stefan-Boltzmann's law, the energy emitted by a black body per unit area and unit time is proportional to the power "four" of the absolute temperature of the body. Stefan-Boltzmann's law is also valid for a so-called "grey" body whose surface shows a wavelength independent absorption-coefficient of less than one. In the experiment, the "grey" body is represented by the filament of an incandescent lamp whose energy emission is investigated as a function of the temperature.

Tasks

1. To measure the resistance of the filament of the incandescent lamp at room temperature and to ascertain the filament's resistance R_0 at zero degrees centigrade.
2. To measure the energy flux density of the lamp at different heating voltages. The corresponding heating currents read off for each heating voltage and the corresponding filament resistance calculated. Anticipating a temperature-dependency of the second order of the filament-resistance, the temperature can be calculated from the measured resistances.

What you can learn about

- Black body radiation
- Thermoelectric e. m. f.
- Temperature dependence of resistances

Main articles

Universal measuring amplifier	13626-93	1
Thermopile, Moll type	08479-00	1
Power supply variable 15 VAC/ 12 VDC/ 5 A	13530-93	1
Optical profile bench l = 60 cm	08283-00	1
Digital multimeter 2010	07128-00	3

Slide mount for optical bench, h = 30 mm	08286-01	2
Lamp holder E 14, on stem	06175-00	1

Cobra4 Experiment - available 2013

Stefan-Boltzmann's law of radiation (with Cobra4)

P2350160

Universal measuring amplifier



Function and Applications

Universal measuring amplifier for amplification of AC and DC voltages. Suitable for practical exercises.

13626-93

P2360100 Solar ray collector



No.	Glass plate	Light	Cold air	ϑ_{in} °C	$\vartheta_{out} - \vartheta_{in}$ K	η %
1.1	+	-	-	≈ 5	2.5	15
1.2	-	-	-	≈ 5	5.0	29
2.1	+	+	-	≈ 20	11.0	64
2.2	-	+	-	≈ 20	12.5	73
3.1	+	+	-	≈ 50	8.0	47
3.2	-	+	+	≈ 50	8.0	47
3.3	+	+	-	≈ 50	6.0	35
3.4	-	+	+	≈ 50	3.0	17

Water temperatures and collector efficiency under various experimental conditions, $m = 100 \text{ cm}^3/\text{min}$, $q_i = 1 \text{ kW/m}^2$, $A = 0.12 \text{ m}^2$.

Principle

The solar ray collector is illuminated with a halogen lamp of known light intensity. The heat energy absorbed by the collector can be calculated from the volume flow and the difference in the water temperatures at the inlet and outlet of the absorber, if the inlet temperature stays almost constant by releasing energy to a reservoir. The efficiency of the collector is determined from this. The measurement is made with various collector arrangements and at various absorber temperatures.

Tasks

To determine the efficiency of the solar ray collector under various experimental conditions.

- Absorption of energy from the environment (20 °C) without illumination by sun or halogen lamp, water temperature at the absorber inlet T_e ; 5 °C.
 1. Absorber with insulation and glassplate (complete collector).
 2. Absorber alone (energy ceiling).
- Illumination with halogen lamp. Water temperature T_e ; 20 °C.
 1. Complete collector.
 2. Collector without glass plate.
- Illumination with halogen lamp. Water temperature T_e ; 50 °C.
 1. Complete collector.
 2. Complete collector, cold jet of air impinges.
 3. Collector without glass plate.
 4. Collector without glass plate, cold jet of air impinges.

What you can learn about

- Absorption; Heat radiation; Greenhouse effect
- Convection; Conduction of heat
- Collector equations; Efficiency; Energy ceiling

Main articles

Solar ray collector	06753-00	1
Circulating pump w. flowmeter	06754-01	1
Halogen lamp 1000 W	08125-93	1
Power supply 0...12 V DC/ 6 V, 12 V AC, 230 V	13505-93	1
Heat exchanger	06755-00	1
Solar collector stand, teaching aid	06757-00	1

Solar ray collector



Function and Applications

Compact unit for study of all collector functions.

Equipment and technical data

- Flat collector to heat water through absorption of radiation energy or thermal energy from environment.
- Black stainless steel absorbers with 2 temperature measurement points at inlet and outlet.

06753-00

Characteristic curves of a solar cell

P2410901

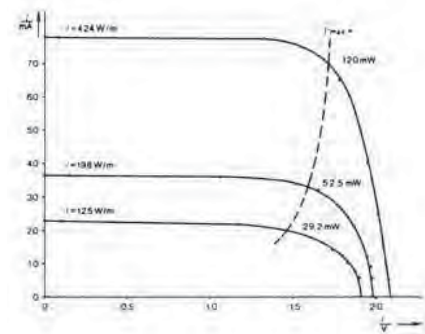

Current-voltage characteristic at different light intensities J .

Principle

The current-voltage characteristics of a solar cell are measured at different light intensities, the distance between the light source and the solar cell being varied. The dependence of no-load voltage and short-circuit current on temperature is determined.

Tasks

1. To determine the light intensity with the thermopile at various distances from the light source.
2. To measure the short-circuit current and no-load voltage at various distances from the light source.
3. To estimate the dependence of no-load voltage, and short-circuit current on temperature.
4. To plot the current-voltage characteristic at different light intensities.
5. To plot the current-voltage characteristic under different operating conditions: cooling the equipment with a blower, no cooling, shining the light through a glass plate.
6. To determine the characteristic curve when illuminated by sunlight.

What you can learn about

- Semiconductor; p-n junction; Energy-band diagram
- Fermi characteristic energy level; Diffusion potential
- Internal resistance; Efficiency; Photo-conductive effect
- Acceptors; Donors; Valence band; Conduction band

Main articles

Universal measuring amplifier	13626-93	1
Thermopile, Moll type	08479-00	1
Rheostat, 330 Ohm , 1.0A	06116-02	1

Ceramic lamp socket E27 with reflector, switch, safety plug	06751-01	1
Solar battery, 4 cells, 2.5 x 5 cm	06752-04	1
Tripod base PHYWE	02002-55	2
Digital multimeter 2010	07128-00	2

Universal measuring amplifier



Function and Applications

Universal measuring amplifier for amplification of AC and DC voltages. Suitable for practical exercises.

13626-93

P2411200 Faraday's law

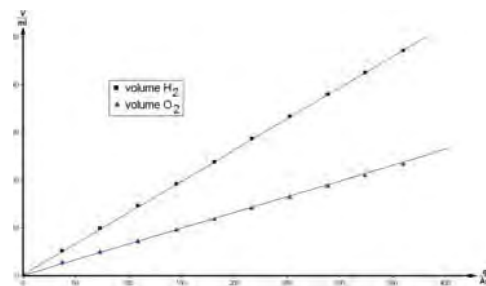

Correlations between the transferred charge and the evolved volumes of hydrogen and oxygen in the electrolysis of diluted sulphuric acid (T = 296.05 K and p = 100.4 kPa).

Principle

The correlation between the amounts of substances transformed in the electrode reaction and the applied charge (amount of electricity) is described by Faraday's law. Faraday's constant, which appears as a proportionality factor, can be determined experimentally from this dependence.

Task

Determine Faraday's constant from the dependence of the volumes of hydrogen and oxygen evolved on the applied charge in the hydrolysis of diluted sulphuric acid.

What you can learn about

- Electrolysis
- Coulometry
- Charge
- Amount of substance
- Faraday's law
- Faraday's constant
- Avogadro's number
- General equation of state for ideal gases

Main articles

Power supply, universal	13500-93	1
Electrolysis apparatus-Hofmann	44518-00	1
Weather monitor, 6 lines LCD	87997-10	1
Digital multimeter 2010	07128-00	1
On/off switch	06034-01	1
Retort stand, h = 750 mm	37694-00	1
Set of Precision Balance Sartorius TE 612 and measure software balances,230V	48836-88	1

Power supply, universal



Function and Applications

Versatile heavy duty power supply which can also be used as a constant current supply in schools, laboratories or workshops.

Equipment and technical data

- Direct current source: Stabilised, regulated output direct voltage, continuously adjustable from 0...18 V
- Adjustable current limit between 0...5 A
- LED display for constant current operation
- Permanently short-circuit proof & protected against exterior voltages
- Alternative voltage output:
- Multitap transformer 2...15 V, outputs galvanically separated from main grid
- Full load capacity (5 A), even if direct current is supplied simultaneously
- Short-circuit protection through overcurrent circuit breaker
- All output voltages available at 4 mm safety plug sockets.

13500-93

Determination of the heat of formation of water

P3021501



$$\Delta n(H_2) = \frac{pV}{RT}$$

General equation of state for ideal gases.

Principle

Standard molar enthalpies of formation ΔH^\ominus are important compiled thermodynamics tabulation quantities for calculating standard enthalpies of reaction for any arbitrary reaction.

They are defined as the heat of reaction occurring in the direct formation of one mole of the pertinent pure substance from the stable pure elements at constant pressure. For spontaneous and quantitative formation reactions, e.g. the conversion of hydrogen and oxygen to water, standard enthalpies of formation can be measured directly using calorimetry.

Task

Determine the enthalpy of formation of water by burning 100 ml H_2 in a closed glass jacket calorimeter.

What you can learn about

- First law of thermodynamics
- Thermochemistry
- Calorimetry
- Enthalpy of formation
- Enthalpy of reaction

Main articles

High voltage supply unit, 0-10 kV	13670-93	1
Glass jacket	02615-00	1
Steel cylinder hydrogen, 2 l, full	41775-00	1
Lid for calorimeter insert	02615-02	1
Steel cylinder oxygen, 2 l, filled	41778-00	1
Calorimeter insert for glass jacket	02615-01	1
Set of Precision Balance Sartorius CPA 623S and measure software, 230 V	49224-88	1

Glass jacket



Function and Applications

Glass jacket, used as cooling or heating mantle.

Benefits

The cylinder is made of DURAN 50®, which gave him an extreme heat resistance, high thermal shock resistance, mechanical strength and excellent chemical resistance.

Equipment and technical data

- Cylindrical glasstube with screw closures for different inserts
- Length: 205 mm
- Outer diameter: 75 mm
- Connecting nut and gasket for flanging cylindrical inserts with an outer diameter of 36 mm watertight and airtight
- 1 Flange with ring nut

02615-00

P2411100 Characteristic curve and efficiency of a PEM fuel cell and a PEM electrolyser

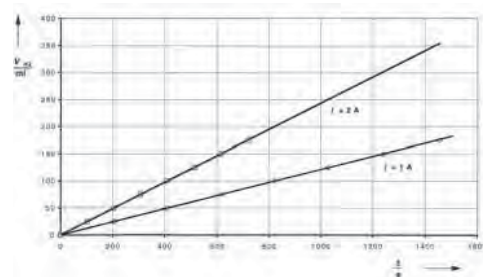

Volume of the hydrogen generated by the PEM electrolyser as a function of time at different current I.

Principle

In a PEM electrolyser, the electrolyte consists of a proton-conducting membrane and water (PEM = Proton-Exchange-Membrane). When an electric voltage is applied, hydrogen and oxygen are formed. The PEM fuel cell generates electrical energy from hydrogen and oxygen. The electrical properties of the electrolyser and the fuel cell are investigated by recording a current-voltage characteristic line. To determine the efficiency, the gases are stored in small gasometers in order to be able to measure the quantities of the gases generated or consumed.

Tasks

1. Recording the characteristic line of the PEM electrolyser.
2. Recording the characteristic line of the PEM fuel cell.
3. Determination of the efficiency of the PEM electrolysis unit.
4. Determination of the efficiency of the PEM fuel cell.

What you can learn about

- Electrolysis; Electrode polarisation
- Decomposition voltage; Galvanic elements
- Faraday's law

Main articles

Power supply, universal	13500-93	1
PEM electrolyser	06748-00	1
Cobra4 Mobile-Link set, incl. rechargeable batteries, SD memory card, USB cable and software "measure"	12620-55	1
PEM fuel cell	06747-00	1
Cobra4 Sensor-Unit Weather: Humidity, Air pressure, Temperature, Light intensity, Altitude	12670-00	1
Gas bar	40466-00	1

Digital multimeter 2010

07128-00 2

PEM electrolyser



Function and Applications

For the production of hydrogen and oxygen through electrolysis.

Equipment and technical data

- Electrolyser and storage container for distilled water mounted on a stable baseplate.
- Without use of caustic lyes or acids.
- Only distilled water is used for operating it.
- Voltage input protected against polarity reversal.
- Operating instructions with detailed description of experiment.
- Electrode surface: 16 cm². Output: 4 W. Voltage required: 1.7...2 V.

06748-00



Photonics

7.1	Basic Principles	166
7.2	Interferometry	178
7.3	Holography	187
7.4	Laser	189
7.5	Fibre Optics	192

P2240405 Lambert's law of radiation on optical base plate

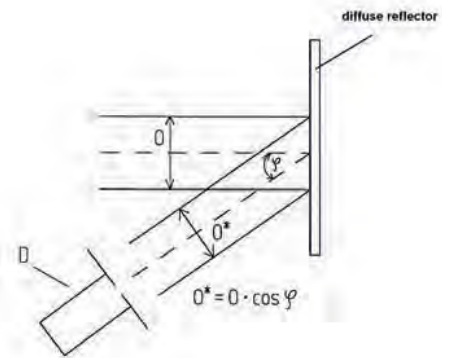

Diagram of the principle of measurements with the used magnitudes (with \varnothing^* as apparent magnitude of surface \varnothing).

Principle

Visible light impinges on a diffusely reflecting surface. The luminance of this surface is determined as a function of the angle of observation.

Tasks

1. The luminous flux emitted reflected by a diffusely reflecting surface is to be determined as a function of the angle of observation.
2. Lambert's law (cos-law) is to be verified using the graph of the measurement values.

What you can learn about

- Luminous flux
- Light quantity
- Light intensity
- Illuminance
- Luminance

Main articles

He/Ne Laser, 5mW with holder	08701-00	1
Power supply for laser head 5 mW	08702-93	1
Universal measuring amplifier	13626-93	1
Optical base plate with rubberfeet	08700-00	1
Rot. guide rail w. angular scale	08717-00	1
Photoelement f. opt. base plt.	08734-00	1
Diaphragm holder f.opt.base plt.	08724-00	1

Related Experiment

Lambert's law

P2240400

Laser, He-Ne, 0.2/1.0 mW, 230 V AC

Function and Applications

Linearly polarised light source, very short design.

Benefits

- Welded glass tube assures a very long lifetime > 18 000 operating hours
- Key switch and integrated greyfilter to reduce radiation power to 0.2 mW. Screw-in release to activate the grey filter.
- Anodised aluminium casing with integrated mains power supply, screw in holding stem, signal light and required warnings printed on both sides. Fixed mains connecting cable 140 cm.

Equipment and technical data

- Wavelength 632.8 nm, optical output power without filter 1.0 mW, with filter 0.2 mW
- Beam diameter 0.5 mm, beam divergence < 2 mrad.
- Minimum polarisation 500:1, max drift over 8 hours \pm 2.5%
- Oscillating mode TEM00, lifetime > 18000 h
- Power requirements 35 VA, connecting voltage 230 V, 50/60 Hz

08180-93

Polarisation through quarter-wave plates with optical base plate

P2250105

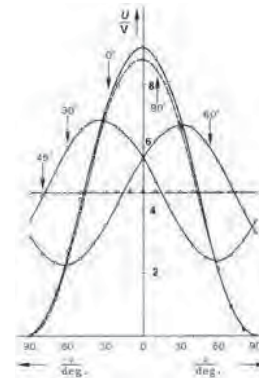

Intensity distribution of polarised light for different angles of the $\lambda/4$ plate, as a function of the analyser position.

Principle

Monochromatic light impinges on amica plate, perpenicularly to its optical axis. If the thickness of the plate is adequate ($\lambda/4$ plate), a phase shift of 90° occurs between the ordinary and the extraordinary beam when the latter leaves the crystal. The polarisation of exiting light is examined for different angles between the optical axis of the $\lambda/4$ plate and the direction of polarisation of incident light.

Tasks

1. Measurement of the intensity of linearly polarised light as a function of the analyser's position (Malus' law).
2. Measurement of the light intensity behind the analyser as a function of the angle between the optical axis of the $\lambda/4$ plate and the analyser.
3. Carrying out experiment (2) with two successive $\lambda/4$ plates.

What you can learn about

- Linearly, circularly an elliptically polarised light
- Polarizer; Analyser; Malus' law; Plane of polarisation
- Double refraction; Optical axis; Ordinary and extraordinary beam

Main articles

He/Ne Laser, 5mW with holder	08701-00	1
Power supply for laser head 5 mW	08702-93	1
Universal measuring amplifier	13626-93	1
Optical base plate with rubberfeet	08700-00	1
Photoelement f. opt. base plt.	08734-00	1
Diaphragm holder f.opt.base plt.	08724-00	2
Polarizing filter f.opt.base pl.	08730-00	2

Related Experiment

Polarisation through quarter-wave plates with optical profile bench

P2250100

Universal measuring amplifier



Function and Applications

Universal measuring amplifier for amplification of AC and DC voltages. Suitable for practical exercises.

13626-93

P2250305 Fresnel's law - theory of reflection with optical base plate

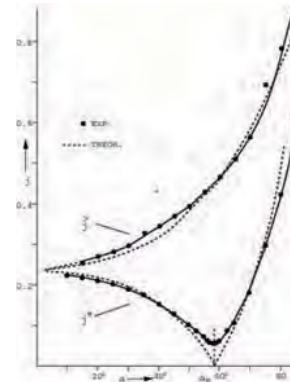

Measurement results.

Principle

Plane-polarized light is reflected at a glass surface. Both the rotation of the plane of polarization and the intensity of the reflected light are to be determined and compared with Fresnel's formulae for reflection.

Tasks

1. The reflection coefficients for light polarized perpendicular and parallel to the plane of incidence are to be determined as a function of the angle of incidence and plotted graphically.
2. The refractive index of the flint glass prism is to be found.
3. The reflection coefficients are to be calculated using Fresnel's formulae and compared with the measured curves.
4. The reflection factor for the flint glass prism is to be calculated.
5. The rotation of the polarization plane for plane polarized light when reflected is to be determined as a function of the angle of incidence and presented graphically. It is then to be compared with values calculated using Fresnel's formulae.

What you can learn about

- Electromagnetic theory of light
- Reflection coefficient; Reflection factor
- Brewster's law
- Law of refraction
- Polarisation; Polarisation level

Main articles

Laser, He-Ne, 0.2/1.0 mW, 230 V AC	08180-93	1
Universal measuring amplifier	13626-93	1
Optical base plate with rubberfeet	08700-00	1
Prism, 60 degrees, h.36.4mm, flint	08237-00	1

Rot. guide rail w. angular scale	08717-00	1
Photoelement f. opt. base plt.	08734-00	1
Polarizing filter f.opt.base pl.	08730-00	2

Related Experiment

Fresnel's equations - theory of reflection with optical profile bench

P2250300

Optical base plate with rubberfeet

Function and Applications

For setting up magnetically adhering optical components.

Equipment and technical data

- Rigid and vibration-damped working base made of steel plate
- With corrosion protection, NEXTEL® plastic coating and imprinted grid (5×5) cm
- Three fixed adapter sleeves for laser and laser shutter
- With rubber feet for non-slip working
- Base plate size (mm): 590 × 430 × 24
- Weight: 7 kg

08700-00

Diffraction at a slit and Heisenberg's uncertainty principle with optical base plate

P2230105

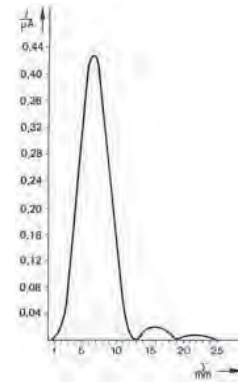

Intensity distribution of the diffraction pattern of a 0.05 mm wide slit, at a distance of 490 mm.

Principle

The intensity distribution in the Fraunhofer diffraction pattern of a slit is measured. Measurement results are evaluated both in the wave representation through comparison with Kirchhoff's diffraction formula and in the photon representation, in order to verify Heisenberg's uncertainty principle.

Tasks

1. The intensity distribution of the Fraunhofer diffraction pattern due to a simple slit is measured. The amplitudes of the peaks and of the minima are calculated according to Kirchhoff's diffraction formula and compared to measured values.
2. Momentum uncertainty is calculated with the assistance of the diffraction patterns of simple slits of different widths, and Heisenberg's uncertainty relation is verified.

What you can learn about

- Diffraction; Sharpness; Kirchhoff's diffraction
- Formula; Measurement precision
- Local uncertainty; Impulse uncertainty
- Wave-matter duality; De Broglie's relation

Main articles

Laser, He-Ne, 0.2/1.0 mW, 230 V AC	08180-93	1
Universal measuring amplifier	13626-93	1
Optical base plate with rubberfeet	08700-00	1
Sliding device, horizontal	08713-00	1
Photoelement f. opt. base plt.	08734-00	1
Diaphragm holder f.opt.base plt.	08724-00	1
Voltmeter,0.3-300VDC,10-300VAC /	07035-00	1

Related Experiment

Diffraction at a slit and Heisenberg's uncertainty principle with optical bench

P2230100



Werner Heisenberg
1932, Nobel Prize in Physics

P2230405 Diffraction of light through a double slit or by a grid with optical base plate

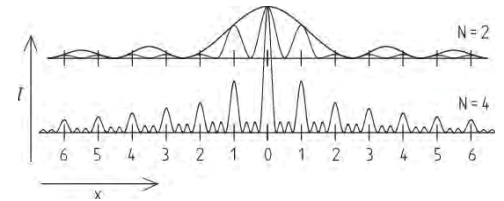

Qualitative intensity distribution of diffraction through 2 and 4 slits, the distance x being normalised to l . The intensity distribution of the simple slit has been represented with exaggerated height to give a clearer view.

Principle

The coherent monochromatic light of a laser is directed to a diaphragm with a varying number of slits. The resulting interference patterns are studied using a photoelement.

Tasks

- The intensity distribution of diffraction patterns formed by multiple slits is measured using a photoelement.
- The dependence of this distribution from the slit widths, the number of slits and the grid constant is investigated.
- The obtained curves are compared to the theoretical values.

What you can learn about

- Fraunhofer diffraction
- Huygens' principle
- Interference
- Coherence

Main articles

He/Ne Laser, 5mW with holder	08701-00	1
Power supply for laser head 5 mW	08702-93	1
Universal measuring amplifier	13626-93	1
Optical base plate with rubberfeet	08700-00	1
Sliding device, horizontal	08713-00	1
Photoelement f. opt. base plt.	08734-00	1
Diaphragm holder f.opt.base plt.	08724-00	1

Related Experiment

Diffraction intensity due to multiple slits and grids with optical profile bench

P2230400

Photoelement for optical base plate



Function and Applications

For determination of light intensities.

Equipment and technical data

- Spectral range: 400 nm...1100 nm.
- With changeable stem $\varnothing = 10\text{mm}$ and $l = 110\text{ mm}$ respectively $l = 250\text{ mm}$.
- Slit diaphragm $d = 0.3\text{mm}$.

08734-00

Diffraction intensity at a slit and at a wire - Babinet's theorem with optical base plate

P2230605

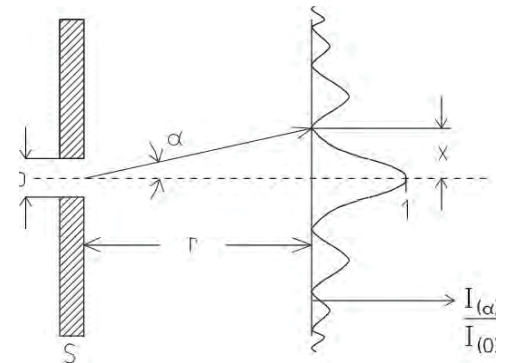

Principle of set up for diffraction through a slit and qualitative distribution on intensities in the detector plane LD.

Principle

Babinet's Principle states that the diffraction pattern for an aperture is the same as the pattern for an opaque object of the same shape illuminated in the same manner. That is the pattern produced by a diffracting opening of arbitrary shape is the same as a conjugate of the opening would produce.

Tasks

Babinet's theorem is verified by the diffraction pattern of monochromatic light directed through a slit and an opaque stripe complementary to the latter. The experiment is also performed with a circular aperture and an opaque obstacle conjugate to this opening.

What you can learn about

- Fraunhofer interference
- Huygens' principle
- Multiple beam interference
- Babinet's theorem
- Coherence

Main articles

He/Ne Laser, 5mW with holder	08701-00	1
Power supply for laser head 5 mW	08702-93	1
Universal measuring amplifier	13626-93	1
Optical base plate with rubberfeet	08700-00	1
Sliding device, horizontal	08713-00	1
Screen, with diffracting elements	08577-02	1
Photoelement f. opt. base plt.	08734-00	1

Related Experiment

Diffraction intensity at a slit and at a wire - Babinet's theorem with optical profile bench

P2230600



P2220205 Newton's rings with optical base plate

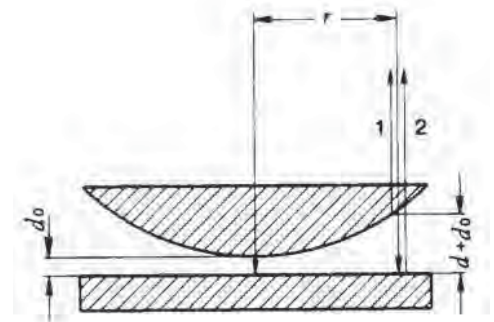

Generation of Newton's rings.

Principle

The air wedge formed between slightly convex lens and a plane glass plate (Newton's colour glass) is used to cause interference of monochromatic light. The wavelength is determined from the radii of the interference rings.

Tasks

The diameters of interference rings produced by Newton's colour glass are measured and these are used to:

1. Determine the wavelength for a given radius of curvature of the lens.
2. Determine the radius of curvature for a given wavelength.

What you can learn about

- Coherent light
- Phase relation
- Path difference
- Interference at thin layers
- Newton's colour glass

Main articles

He/Ne Laser, 5mW with holder	08701-00	1
Power supply for laser head 5 mW	08702-93	1
Optical base plate with rubberfeet	08700-00	1
Newton colourglass f.opt.b. pl.	08730-02	1
Sliding device, horizontal	08713-00	1
xy shifting device	08714-00	2
Pin hole 30 micron	08743-00	1

Related Experiment

Newton's rings with interference filters

P2220200

He/Ne Laser, 5mW with holder



Function and Applications

He/Ne laser with fixed connection cable with HV jack for laser power pack.

Equipment and technical data

- Wave length 632.8 nm
- Modes TEM₀₀
- Degree of polarisation 1:500
- Beam diameter 0.81 mm
- Beam divergence 1 mrad
- Max. power drift max. 2.5%/ 8 h
- Service life ca. 15000 h
- Coaxial cylinder casing $\varnothing = 44.2\text{mm}$, $l = 400\text{ mm}$
- Incl. 2 holders with three-point bearing and 2 setting collars

08701-00

Polarimetry with optical base plate

P2250505

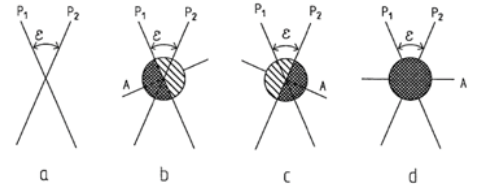

Working principle of the half shadow polarimeter.

Principle

Optically active substances cause very slight rotations of the light polarisation plan, which the method of crossed polarisation filters is not strong enough to measure. With this method, the direction of polarisation of the analyser is perpendicular to that of the polarizer. If an optically active substance is placed between them, the polarisation direction of the analyser must be corrected by the corresponding angle of rotation of the plane of polarisation in order to obtain an intensity minimum again. A stronger adjustment possibility for the determination of the angle is given with the half shadow polarimeter, used in this experiment to measure the angle of rotation of the plane of polarisation caused by glucose-water solutions of different concentrations.

Task

Determine the angle of rotation for sugar solutions of different concentrations.

What you can learn about

- Lippich polariser
- Malus' law

Main articles

Laser, He-Ne, 0.2/1.0 mW, 230 V AC	08180-93	1
Optical base plate with rubberfeet	08700-00	0
Pol.filter halfshade f.opt.b.pl.	08730-01	1
Polarizing filter f.opt.base pl.	08730-00	2
Adjusting support 35 x 35 mm	08711-00	1
Surface mirror 30 x 30 mm	08711-01	1
Holder,dir.vis. prism,opt.b.pl.	08726-00	1

Related Experiment

Polarimetry

P2250200

Laser, He-Ne, 0.2/1.0 mW, 230 V AC



Function and Applications

Linearly polarised light source, very short design.

Benefits

- Welded glass tube assures a very long lifetime > 18 000 operating hours; Key switch and integrated greyfilter to reduce radiation power to 0.2 mW. Screw-in release to activate the grey filter.
- Anodised aluminium casing with integrated mains power supply, screw in holding stem, signal light and required warnings printed on both sides. Fixed mains connecting cable 140 cm.

08180-93

P2260106 Faraday effect with optical base plate

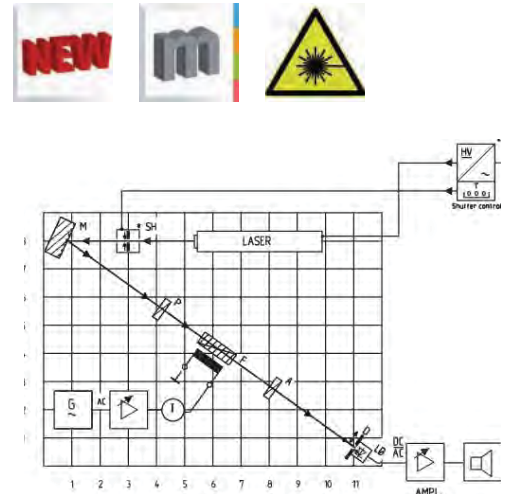

Experimental setup.

Principle

When the Faraday effect was discovered in 1845 it was the first experiment that elucidated the relation of light and electromagnetism. If linearly polarised light passes through a region with magnetic field the angle of rotation of the plane of polarisation is altered. This alteration appears to be a linear function of both the average magnetic flow density and the distance that the wave covers in the magnetic field. The factor of proportionality is a medium-specific constant and is called Verdet's constant.

Task

Investigate the Faraday effect qualitatively through observation of the electro optical modulation of the polarised laser light with frequencies in the acoustic range.

What you can learn about

- Interaction of electromagnetic fields
- Electromagnetism
- Polarisation
- Verdet's constant
- Malus' law
- Electronic oscillation

Main articles

Digital Function Generator, USB, incl. Cobra4 Software	13654-99	1
Laser, He-Ne, 0.2/1.0 mW, 230 V AC	08180-93	1
Universal measuring amplifier	13626-93	1
Optical base plate with rubberfeet	08700-00	1
Faraday modulator f.opt.base pl.	08733-00	1
Loudspeaker, 8 Ohm/5 kOhm	13765-00	1
Photoelement f. opt. base pl.	08734-00	1

Related Experiment

Faraday effect with optical profile bench

P2260100

Faraday modulator for optical base plate



Function and Applications

Copper coil on temperature-stable aluminium winder with insert for holding glass rods (SF58) for Faraday effect.

Equipment and technical data

- With round stem, clamp screws and fixed connection cable = 1m with 4-mm jacks
- Number of windings 1200
- Inductivity 6.3 mH
- Ohm's resistance 4 Ω
- Internal diameter 14 mm
- Max. current 5 A (1min)

08733-00

Fourier optics - 2f arrangement

P2261100

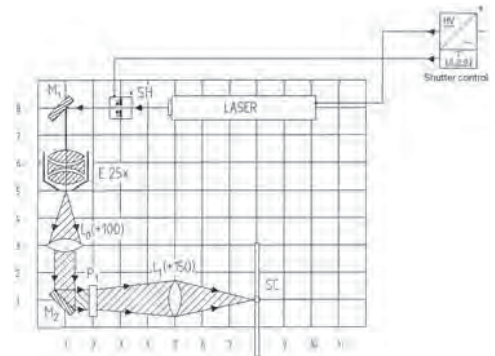
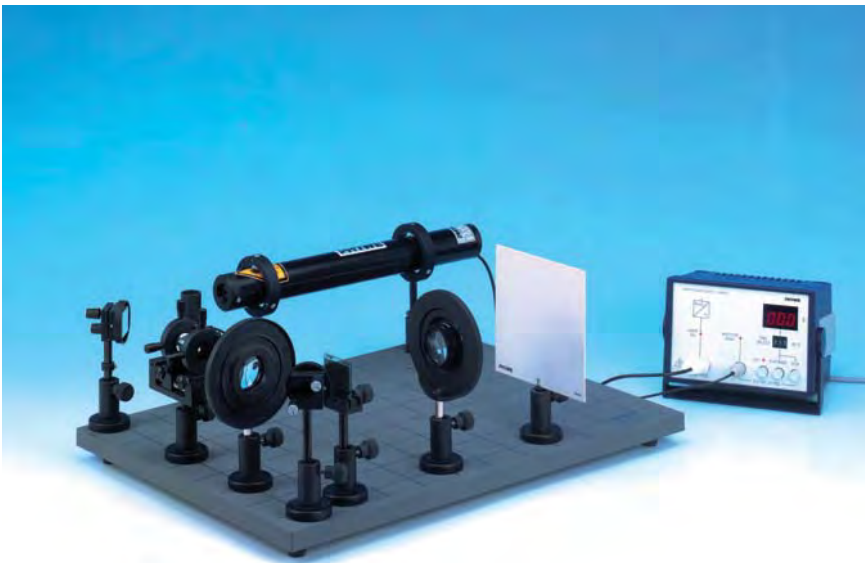

Experimental setup for the fundamental principles of Fourier optic (2f setup).

Principle

The electric field distribution of light in a specific plane (object plane) is Fourier transformed into the $2f$ configuration.

Task

Investigation of the Fourier transform by a convex lens for different diffraction objects in a $2f$ set-up.

What you can learn about

- Fourier transform
- Lenses
- Fraunhofer diffraction
- Index of refraction
- Huygens' principle

Main articles

He/Ne Laser, 5mW with holder	08701-00	1
Power supply for laser head 5 mW	08702-93	1
Optical base plate with rubberfeet	08700-00	1
Sliding device, horizontal	08713-00	1
Screen, with diffracting elements	08577-02	1
xy shifting device	08714-00	2
Pin hole 30 micron	08743-00	1



P2261200 Fourier optics - 4f arrangement - filtering and reconstruction

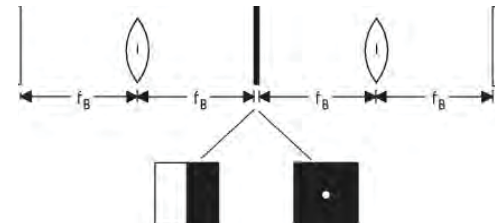

Principle of the setup for coherent optical filtration.

Principle

The electric field distribution of light in a specific plane (object plane) is Fourier transformed into the 4f configuration by 2 lenses and optically filtered with appropriate diaphragms.

Tasks

1. Optical filtration of diffraction objects in 4 f setup.
2. Reconstruction of a filtered image.

What you can learn about

- Fourier transform
- Lenses
- Fraunhofer diffraction
- Index of refraction
- Huygens' principle
- Fog technique

Main articles

Ultrasonic generator	13920-99	1
He/Ne Laser, 5mW with holder	08701-00	1
Power supply for laser head 5 mW	08702-93	1
Optical base plate with rubberfeet	08700-00	1
Sliding device, horizontal	08713-00	1
Screen, with diffracting elements	08577-02	1
Glass cell, 150x55x100 mm	03504-00	1



LDA - laser Doppler anemometry with optical base plate (with Cobra3)

P2260511

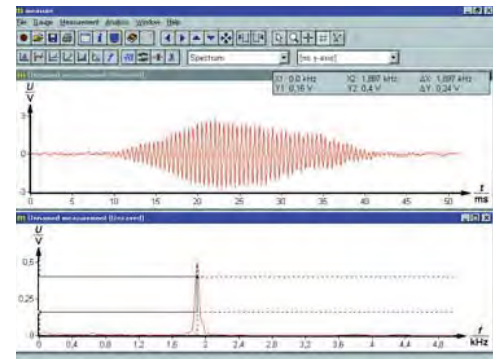

Measurement of the signal spectrum with a signal peak.

Principle

Small particles in a current pass through the LDA measuring volume and scatter the light whose frequency is shifted by the Doppler effect due to the particle movement.

The frequency change of the scattered light is detected and converted into a particle or flow velocity.

Task

Measurement of the light-frequency change of individual light beams which are reflected by moving particles.

What you can learn about

- Interference
- Doppler effect
- Scattering of light by small particles (Mie scattering)
- High- and low-pass filters
- Sampling theorem
- Spectral power density
- Turbulence

Main articles

He/Ne Laser, 5mW with holder	08701-00	1
Power supply for laser head 5 mW	08702-93	1
Cobra3 BASIC-UNIT, USB	12150-50	1
Si-Photodetector with Amplifier	08735-00	1
Optical base plate with rubberfeet	08700-00	1
Sliding device, horizontal	08713-00	1
Control Unit for Si-Photodetector	08735-99	1

Cobra4 Experiment - available 2013

LDA - laser Doppler anemometry (with Cobra4)

P2260560

Control Unit for Si-Photodetector

Function and Applications

Amplifier for silicon photodetector.

Equipment and technical data

- 3 BNC outputs:
 - Output 1 (monitor output), gain 1, bandwidth for DC ... 60 kHz
 - Output 2, gain 1 ... 100, band width for AC 10 Hz ... 60 kHz
 - Output 3 (filter output), gain 1 ... 100, band width for AC 200 Hz ... 10 kHz
- Input: 5-pole diode socket for silicon photodetector
- Connections +9 V ... +12 V, Power consumption 1 W
- Impact-resistant plastic case (194 x 140 x 130) mm with carrying handle; Includes 110-V/240-V power supply

08735-99

P2220505 Michelson interferometer with optical base plate

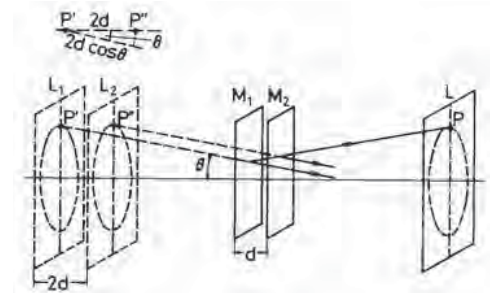
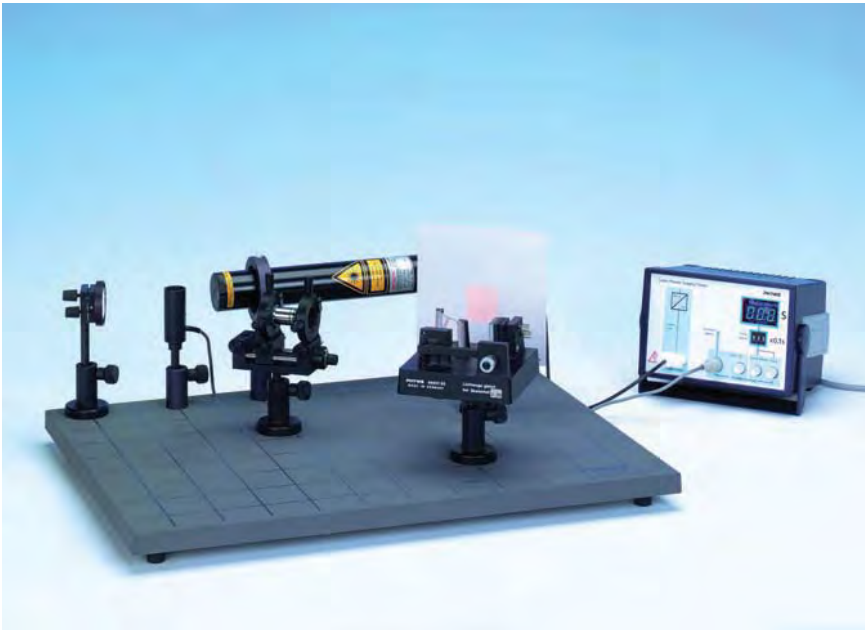

Formation of interference rings.

Principle

In a Michelson interferometer, a lightbeam is split into two partial beams by a semi transparent glass plate (amplitude splitting). These beams are reflected by two mirrors and brought to interference after they passed through the glass plate a second time.

Task

The wavelength of the used laserlight is determined through the observation of the change in the interference pattern upon changing the length of one of the interferometer arms.

What you can learn about

- Interference
- Wavelength
- Refraction index
- Light velocity
- Phase
- Virtual light source
- Coherence

Main articles

Michelson interferometer	08557-00	1
He/Ne Laser, 5mW with holder	08701-00	1
Power supply for laser head 5 mW	08702-93	1
Optical base plate with rubberfeet	08700-00	1
Sliding device, horizontal	08713-00	1
xy shifting device	08714-00	2
Pin hole 30 micron	08743-00	1

Related Experiment

Michelson interferometer with optical profile bench

P2220500



Albert A. Michelson
1907, Nobel Prize in Physics

Refraction index of CO₂ with the Michelson interferometer with optical base plate

P2220705

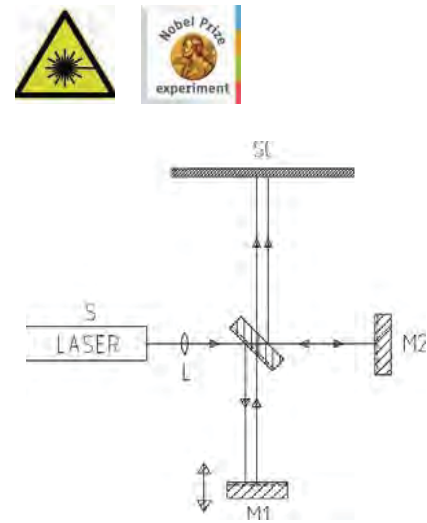

Michelson's setup for interference.

Principle

Light is caused to interfere by means of a beam splitter and two mirrors according to Michelson's set up. Substituting the air in a measurement cuvette located in one of the interferometer arms by CO₂ gas allows to determine the index of refraction of CO₂.

Task

Determine the difference of the refraction index between air and CO₂ from changes in the interference pattern.

What you can learn about

- Interference
- Wavelength
- Index of refraction
- Light velocity
- Phase
- Virtual light source
- Coherence

Main articles

Michelson interferometer	08557-00	1
He/Ne Laser, 5mW with holder	08701-00	1
Power supply for laser head 5 mW	08702-93	1
Optical base plate with rubberfeet	08700-00	1
Sliding device, horizontal	08713-00	1
xy shifting device	08714-00	2
Pin hole 30 micron	08743-00	1

Related Experiment

Refraction index of air and CO₂ with the Michelson interferometer with optical profile bench

P2220700

Michelson interferometer



Function and Application

To measure light wavelengths and refractivity of liquids and gases.

Equipment and technical data

- Metalbase-plate 120 x 120 mm with removable holding stem and with adjustable surface mirrors 30 x 30 mm
- Two polarising filters and micrometer
- Fine shoots to the tilt adjustment of fixed mirror
- Bracket for additional required cell for investigation of gases

08557-00

P2220900 **Michelson interferometer - High Resolution with optical base plate**

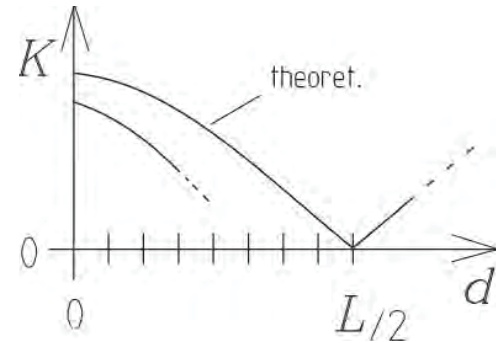
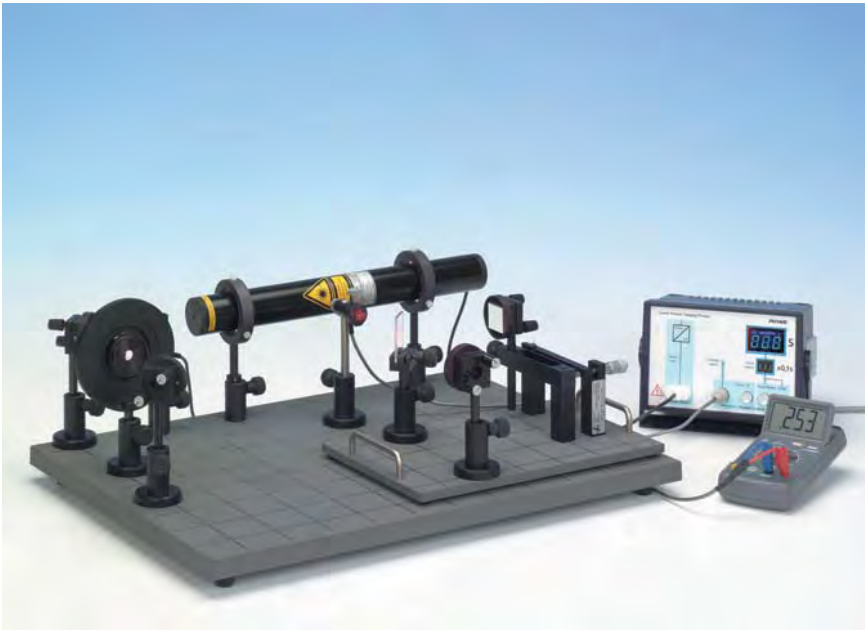

Experimentally determined contrast function in comparison to the theoretical contrast function K of a 2-mode laser.

Principle

With the aid of two mirrors in a Michelson arrangement, light is brought to interference. While moving one of the mirrors, the alteration in the interference pattern is observed and the wave length of the laser light determined.

Tasks

1. Construction of a Michelson interferometer using separate components.
2. The interferometer is used to determine the wavelength of the laser light.
3. The contrast function K is qualitatively recorded in order to determine the coherence length with it.

What you can learn about

- Interference; Wavelength; Diffraction index
- Speed of light; Phase; Virtual light source

Main articles

He/Ne Laser, 5mW with holder	08701-00	1
Power supply for laser head 5 mW	08702-93	1
Interferometerplate w prec.drive	08715-00	1
Optical base plate with rubberfeet	08700-00	1
Surface mirror 30 x 30 mm	08711-01	4

Related Experiment

Twyman-Green interferometer

P2221305

Interferometerplate with precision drive



Function and Applications

For precise and reproducible linear shift of optical components e.g. in interferometer setups.

Equipment and technical data

- Suppression of tilting effects due to traverse construction.
- Wavelength adjustment through lever device with micrometer screw.
- Stiff steel base plate with NEXTEL®-Plastic coating.
- Set up on base plate.
- Shift path: max. 0.25 mm.
- Resolution: 500 nm.
- Dimensions (mm): 320 × 200 × 14.
- Mass: 5 kg.

08715-00

Magnetostriction with the Michelson interferometer

P2430800

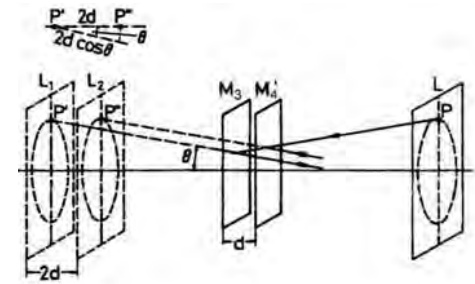

Formation of circular interference fringes.

Principle

With the aid of two mirrors in a Michelson arrangement, light is brought to interference. Due to the magnetostrictive effect, one of the mirrors is shifted by variation in the magnetic field applied to a sample, and the change in the interference pattern is observed.

Tasks

1. Construction of a Michelson interferometer using separate optical components.
2. Testing various ferromagnetic materials (iron and nickel) as well as a non-ferromagnetic material (copper), with regard to their magnetostrictive properties.

What you can learn about

- Interference
- Wavelength
- Diffraction index
- Speed of light
- Phase
- Virtual light source
- Ferromagnetic material
- Weiss molecular magnetic fields
- Spin-orbit coupling

Main articles

He/Ne Laser, 5mW with holder	08701-00	1
Power supply for laser head 5 mW	08702-93	1
Power supply, universal	13500-93	1
Optical base plate with rubberfeet	08700-00	1
Faraday modulator f.opt.base pl.	08733-00	1
Rods for magnetostriction, set	08733-01	1
Adjusting support 35 x 35 mm	08711-00	3

Power supply for laser head 5 mW

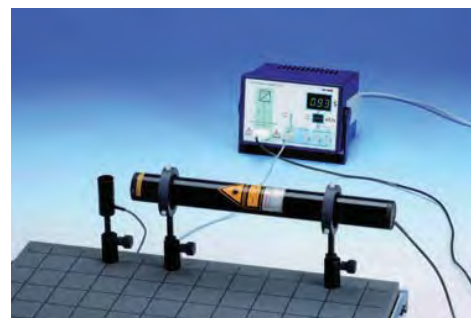

Function and Applications

High voltage power supply for lasers, e. g. the 5 mW laser (08701-00).

Equipment and technical data

- With programmable timer for selection of exposure time of holograms between 0.1 ... 99 s.
- With acontrollable shutter.
- Digital display for preset shutter times as well as those which have already occurred.
- Shutter control via time select, new start, stop and shutter open (permanent open).
- Dimensions of plastic housing (mm): 184 x 140 x 130.
- Incl. shutter with fixed connection cord with unit plug on holding rod.
- Rod diameter: 10 mm.

08702-93

P2221000 Doppler effect with the Michelson interferometer with optical base plate

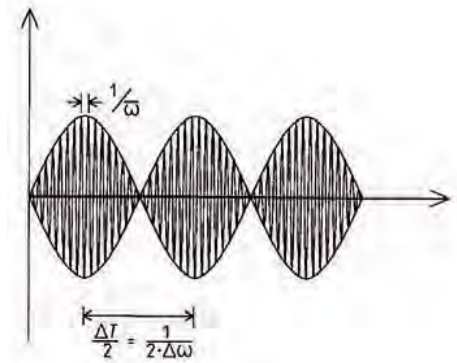

Resulting difference signal during interferometric measurement.

Principle

With the aid of two mirrors in a Michelson arrangement, light is brought to interference. While moving one of the mirrors, the alteration in the interference pattern is observed and the modulation frequency is measured using the Doppler effect.

Tasks

1. Construction of a Michelson interferometer using separate components.
2. Measurement of the Doppler effect via uniform displacement of one of the mirrors.

What you can learn about

- Interference
- Wavelength
- Diffraction index
- Speed of light
- Phase
- Virtual light source
- Temporal coherence
- Special relativity theory
- Lorentz transformation

Main articles

Recorder, tY, 2 channel	11415-95	1
He/Ne Laser, 5mW with holder	08701-00	1
Power supply for laser head 5 mW	08702-93	1
Interferometerplate w prec.drive	08715-00	1
Optical base plate with rubberfeet	08700-00	1
Light barrier with counter	11207-30	1
Power supply 0...12 V DC/ 6 V, 12 V AC, 230 V	13505-93	1

Light barrier with counter



Function and Applications

With the function of an electronic time measuring and counting device.

Benefits

- 4 figure luminous display, selection switch for 4 operating modes
- RESET key, BNC jack for exterior starting and/ or stopping of time measurement, TTL output to control peripheral devices
- power supply connector (4 mm jacks)

Equipment and technical data

- Fork width: 70 mm, Usable barrier depth: 65 mm
- Sensitivity adjustable, LED-Display: 4digits, 8 mm
- Time measurement: 0...9,999 s, Counting: 0...9999
- Supply voltage: 5 V DC, Max. working frequency: 25 kHz
- External dimensions (mm): 160 x 25 x 105M6
- Threaded holes in casing: 7, Stem included: 100 mm, M6 thread

11207-30

Refraction index of air with the Mach-Zehnder interferometer with optical base plate

P2221100

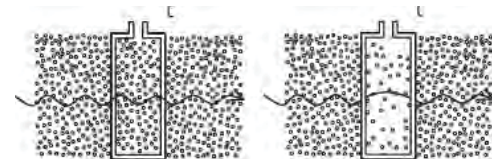

Schematic representation of the cell with normal pressure (a) and nearly absolute vacuum (b).

Principle

Light is brought to interference by two mirrors and two beam splitters in the Mach-Zehnder arrangement. By changing the pressure in a measuring cell located in the beam path, one can deduce the refraction index of air.

Tasks

1. Construction of a Mach-Zehnder interferometer using individual optical components.
2. Measurement of the refraction index n of air by lowering the air pressure in a measuring cell.

What you can learn about

- Interference
- Wavelength
- Diffraction index
- Speed of light
- Phase
- Virtual light source

Main articles

He/Ne Laser, 5mW with holder	08701-00	1
Power supply for laser head 5 mW	08702-93	1
Optical base plate with rubberfeet	08700-00	1
Sliding device, horizontal	08713-00	1
xy shifting device	08714-00	2
Pin hole 30 micron	08743-00	1
Adjusting support 35 x 35 mm	08711-00	4



P2220800 Quantum eraser



Pattern seen on the screen when blocking half of the beam.

Principle

A Mach-Zehnder-interferometer is illuminated with a laser beam. Circular interference fringes appear on the screens behind the interferometer. If polarisation filters with opposite polarisation planes are placed in the two interferometer paths the interference patterns disappear. Placing another polariser before one of the screens causes the pattern to reappear. Electromagnetic radiation can be described both in terms of propagating waves, as well as particles (photons). The experiment illustrates this duality by showing how interference patterns can be explained on the basis of both classical wave mechanics and quantum physics.

Tasks

1. Set up the experiment and observe the interference pattern on the screen.
2. Change the polarisation of the beams with the PF1 and PF2 polarisers and observe the influence on the interference pattern.
3. Use the third polariser PF3 to cancel the polarisation of the light in the two beams, and observe the reappearance of the interference pattern.

What you can learn about

- Wave-particle duality
- Wave interference
- Quantum mechanics

Main articles

Laser, He-Ne, 0.2/1.0 mW, 230 V AC	08180-93	1
Optical base plate in exp.case	08700-01	1
Diaphragm holder f.opt.base plt.	08724-00	1
Polarizing filter f.opt.base pl.	08730-00	3

Adjusting support 35 x 35 mm	08711-00	4
Polarization specimen, mica	08664-00	1
Surface mirror 30 x 30 mm	08711-01	4

Diaphragm holder for optical base plate



Function and Applications

Diaphragm holder for optical base plate with shortstem l = 35 mm.

08724-00

Fabry-Perot interferometer - determination of the wavelength of laser light on optical base plate

P2221205

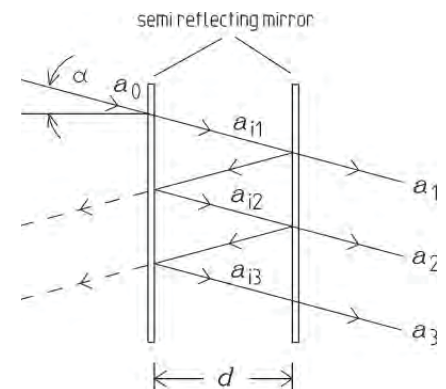
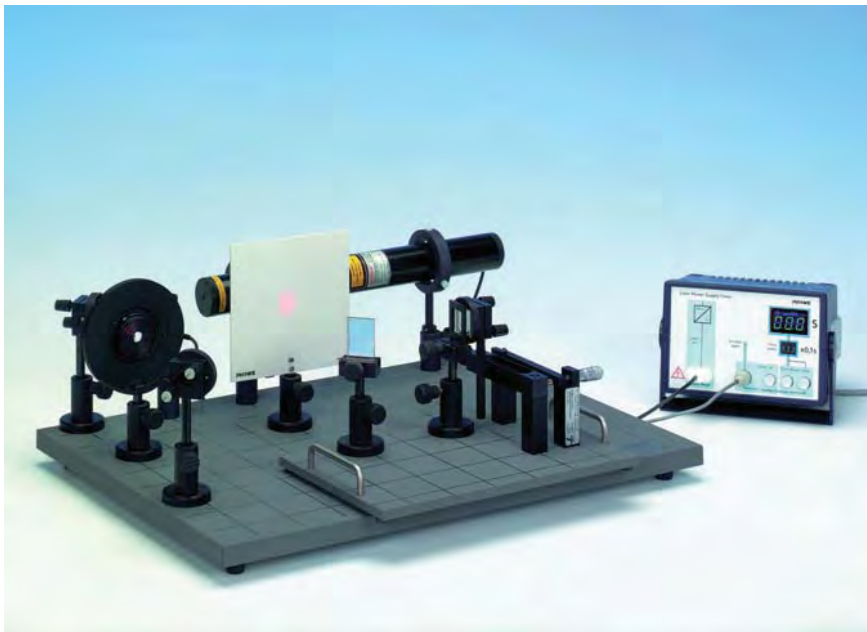

Multibeam interferometer after Fabry and Perot. Illustration of the principle for deriving the individual amplitudes.

Principle

Two mirrors are assembled to form a Fabry-Perot interferometer. Using them, the multibeam interference of a laser's light beam is investigated. By moving one of the mirrors, the change in the interference pattern is studied and the wavelength of the laser's light determined.

Tasks

1. Construction of a Fabry-Perot interferometer using separate optical components.
2. The interferometer is used to determine the wavelength of the laser light.

What you can learn about

- Interference
- Wavelength
- Diffraction index
- Speed of light
- Phase

Main articles

He/Ne Laser, 5mW with holder	08701-00	1
Power supply for laser head 5 mW	08702-93	1
Interferometerplate w prec.drive	08715-00	1
Beam splitter T=30,R=70, w holder	08741-01	1
Optical base plate with rubberfeet	08700-00	1
Adjusting support 35 x 35 mm	08711-00	3
Surface mirror 30 x 30 mm	08711-01	3

Optical base plate with rubberfeet

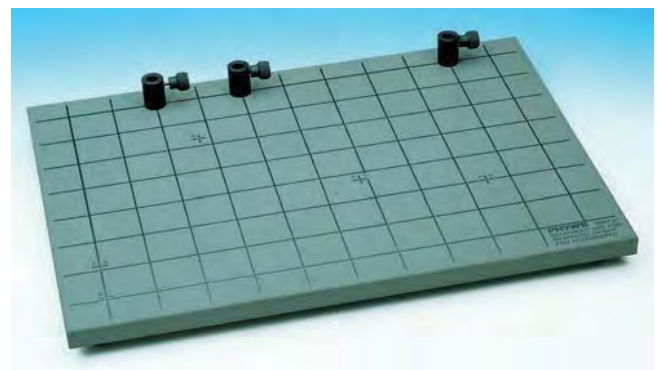

Function and Applications

For setting up magnetically adhering optical components.

Equipment and technical data

- Rigid and vibration-damped working base made of steel plate.
- With corrosion protection, NEXTEL® plastic coating and imprinted grid (5x5) cm.
- Three fixed adapter sleeves for laser and laser shutter.
- With rubber feet for non-slip working.
- Base plate size (mm): 590 × 430 × 24
- Mass: 7 kg

08700-00

P2221206 Fabry-Perot interferometer - optical resonator modes

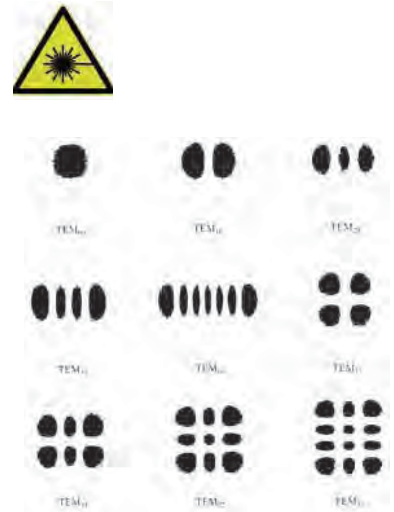
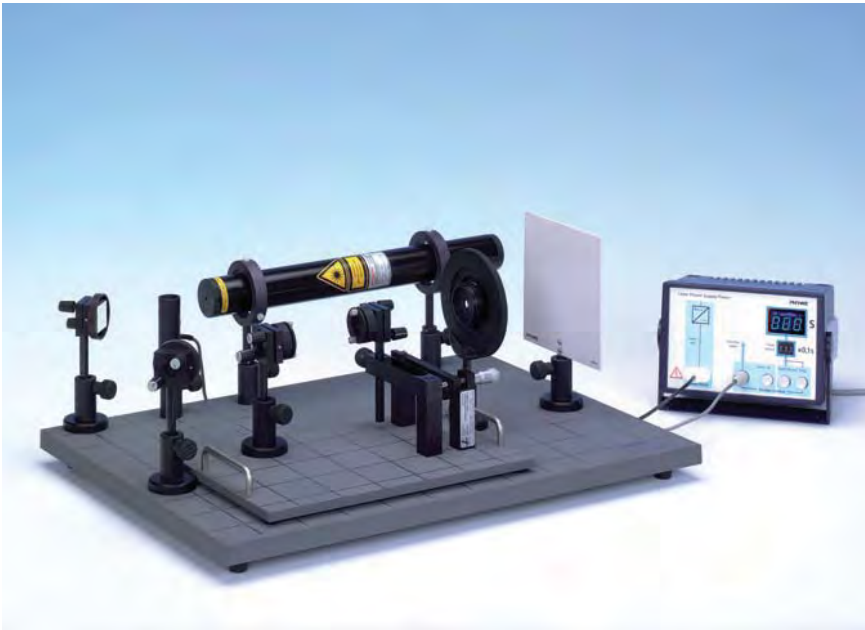

Intensity distribution of the Hermitian-Gaussian resonator modes.

Principle

Two mirrors are assembled to form a Fabry-Perot Interferometer. Using them, the multibeam interference of a laser's light beam is investigated. On moving one of the mirrors, the change in the intensity distribution of the interference pattern is studied. This is a qualitative experiment, to study the shape of different laser modes and compare it with some photos given in the description.

Tasks

1. Construction of a Fabry-Perot interferometer using separate optical components.
2. The interferometer is used to observe different resonator modes within the interferometer.

What you can learn about

- Interference
- Wavelength
- Diffraction index
- Speed of light
- Phase
- Virtual light source
- Two-beam interferometer

Main articles		
He/Ne Laser, 5mW with holder	08701-00	1
Power supply for laser head 5 mW	08702-93	1
Concave mirror OC; $r=1.4m,T=1.7\%$	08711-03	1
Interferometerplate w prec.drive	08715-00	1
Plane mirror HR>99%,mounted	08711-02	1
Optical base plate with rubberfeet	08700-00	1
Adjusting support 35 x 35 mm	08711-00	4



Recording and reconstruction of holograms with optical base plate

P2260300

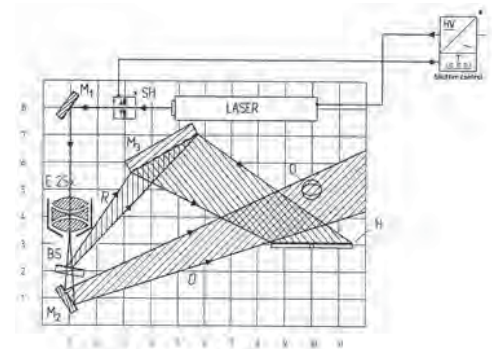

Setup for recording and reconstruction of a transmission hologram.

Principle

In contrast to normal photography a hologram can store information about the three-dimensionality of an object. To capture the three-dimensionality of an object, the film stores not only the amplitude but also the phase of the light rays. To achieve this, a coherent light beam (laser light) is split into an object and a reference beam by being passed through a beam splitter. These beams interfere in the plane of the holographic film. The hologram is reconstructed with the reference beam which was also used to record the hologram.

Tasks

1. Record a laser light hologram and process it to get a phase hologram. Reconstruct it by verifying the virtual and the real image.
2. Record a white light reflection hologram and process it to get a phase hologram. Laminate it for reconstruction by a white light source.

What you can learn about

- Object beam; Reference beam; Real and virtual image
- Phase holograms; Amplitude holograms; Interference
- Diffraction; Coherence; Developing of film

Main articles

He/Ne Laser, 5mW with holder	08701-00	1
Power supply for laser head 5 mW	08702-93	1
Optical base plate in exp.case	08700-01	1
Surface mirror, large, d=80 mm	08712-00	1
Holographic plates, 25 pieces	08746-00	1
Sliding device, horizontal	08713-00	1
Darkroom equipment for holography, 230 V	08747-88	1

Optical base plate in exp.case



Function and Applications

For vibration-damped storage of magnetic adherent optical components.

Equipment and technical data

- Bottom clamp screws.
- When carrying out the experiments, the base plate remains in the bottom of the case.
- Separate case hood with lock.
- Case dimensions (mm): 620 × 460 × 280.
- Mass: 13 kg.

08700-01

P2260305 Transfer hologram - master hologram

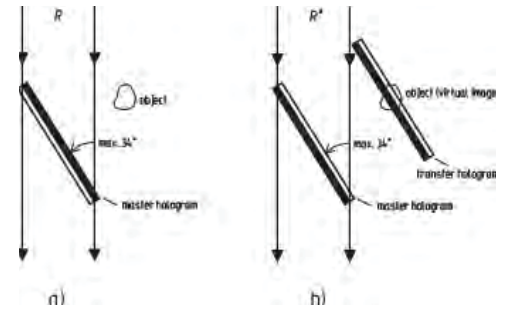

Correct selection of the object position so that the image-capture of a transfer hologram is possible.

Principle

In contrast to normal photography a hologram can store information about the three-dimensionality of an object. To capture the three-dimensionality of an object, the film stores not only the amplitude but also the phase of the light rays. To achieve this, a coherent light beam (laser light) is split into an object and a reference beam by being passed through a beam splitter. These beams interfere in the plane of the holographic film. The hologram is reconstructed with the reference beam which was also used to record the hologram.

Tasks

1. Capture the holographic image of an object.
2. Perform the development and bleaching of this phase hologram.
3. Reconstruct the transmission hologram (reconstruction beam is the reference beam during image capture).

What you can learn about

- Object beam; Reference beam; Real and virtual image
- Phase holograms; Amplitude holograms
- Interference; Diffraction
- Coherence; Developing of film

Main articles

He/Ne Laser, 5mW with holder	08701-00	1
Power supply for laser head 5 mW	08702-93	1
Optical base plate in exp.case	08700-01	1
Surface mirror, large, d=80 mm	08712-00	1
Holographic plates, 25 pieces	08746-00	1
Sliding device, horizontal	08713-00	1
Darkroom equipment for holography, 230 V	08747-88	1

Related Experiment

Holography - Real time procedure

P2260306

Advanced Optics, Holography package incl. manual, 230 V

Function and Applications

A complete set to perform the following experiments using the experimental system "Advanced Optics" incl. handbook "Holography" with 11 described experiments:

- white light holography
- transmission holography
- transfer a hologram from a master hologram

With the aid of a base plate and magnetic adhering holders, which can be positioned jolt-free, 1- and 2-dimensional setups can be quickly and reliably realised. By folding the lightpaths experiments with larger focal distances can be carried out on the working base. The high stiffness and vibration damping of the base plate allows sensitive holography arrangement to be set up.

08700-55

Helium neon laser, basic experiment

P2260701

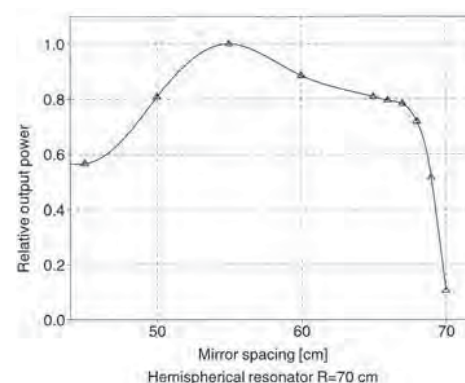
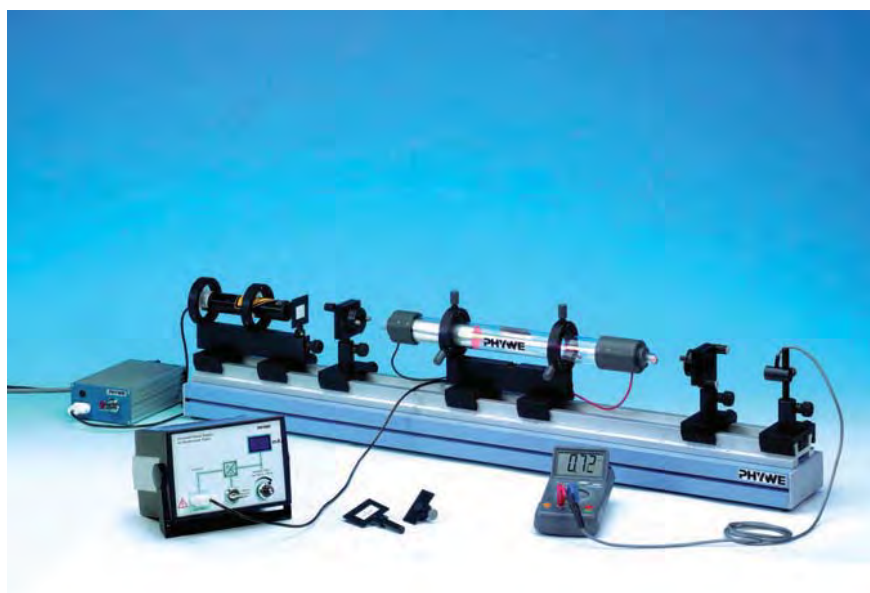

Relative output power as a function of mirror spacing.

Principle

The difference between spontaneous and stimulated emission of light is demonstrated. The beam propagation within the resonator cavity of a He-Ne laser and its divergence are determined, its stability criterion is checked and the relative output power of the laser is measured as a function of the tube's position inside the resonator and of the tube current. The following items can be realised with advanced set 08656-02. By means of a birefringent tuner and a Littrow prism different wavelengths can be selected and quantitatively determined if a monochromator is available. Finally you can demonstrate the existence of longitudinal modes and the gain profile of the He-Ne laser provided an analysing Fabry Perot system is at your disposal.

Tasks

1. Set up the He-Ne laser. Adjust the resonator mirrors by use of the pilot laser (left mirror: VIS, HR, plane; right mirror: VIS, HR, R = 700 mm).
2. Check on the stability condition of a hemispherical resonator.
3. Measure the integral relative output power as a function of the laser tube's position within the hemispherical resonator.
4. Measure the beam diameter within the hemispherical resonator right and left of the laser tube.
5. Determine the divergence of the laser beam.
6. Measure the integral relative output power as a function of the tube current.

What you can learn about

- Spontaneous and stimulated light emission; Inversion
- Collision of second type; Gas discharge tube; Resonator cavity
- Transverse and longitudinal resonator modes
- Birefringence; Brewster angle
- Littrow prism; Fabry Perot Etalon

Main articles

Exp.Set-Helium-Neon Laser	08656-93	1
Sliding device, horizontal	08713-00	1
Protection glasses HeNe-laser	08581-10	1
Photoelement f. opt. base plt.	08734-00	1
Cleaning set for laser	08582-00	1
Diffraction grating, 600 lines/mm	08546-00	1
DMM, auto range, NiCr-Ni thermocouple	07123-00	1

Related Experiment

Helium neon laser, advanced experiment

P2260705

Training recommended **Service** | PHYWE

For this experiment we recommend a seminar on equipment technology, handling and information of equipment-specific characteristics on site.

03333-02

P2260800 Optical pumping

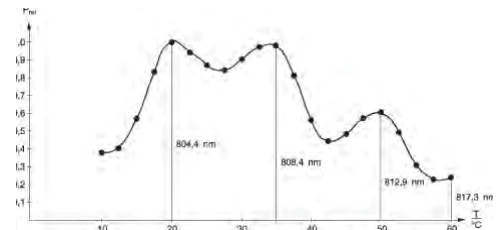

Relative fluorescent power of the Nd:YAG rod as a function of the diode power temperature (wavelength) for $I = 450$ mA.

Principle

The visible light of a semiconductor diode laser is used to excite the neodymium atoms within a Nd:YAG (Neodymium Yttrium Aluminium Garnet) rod. The power output of the semiconductor diode laser is first recorded as a function of the injection current. The fluorescent spectrum of the Nd:YAG rod is then determined and the main absorption lines of the Nd-atoms are verified. Conclusively, the mean life-time of the $4F3/2$ -level of the Nd-atoms is measured in approximation.

Tasks

1. To determine the power output of the semiconductor diode laser as a function of the injection current.
2. To trace the fluorescent spectrum of the Nd:YAG rod pumped by the diode laser and to verify the main absorption lines of neodymium.
3. To measure the mean life-time of the $4F3/2$ -level of the Nd-atoms.
4. For further applications see experiment "Nd:YAG laser".

What you can learn about

- Spontaneous emission
- Induced emission
- Mean lifetime of a metastable state
- Relaxation; Inversion; Diode laser

Main articles

Basic set optical pumping	08590-93	1
Sensor f. measur. of beam power	08595-00	1
30 MHz digital storage oscilloscope with colour display, 2 x BNC cables $l = 75$ cm incl.	11462-99	1
Protection glasses for Nd:Yag laser	08581-20	1
Digital multimeter 2010	07128-00	1

Basic set optical pumping

Function and Applications

The light from a lasersiode is used to excite neodymium atoms in a Nd:YAG crystal.

Benefits

- The power emitted by the laser diode can be measured as a function of the supply current.
- The fluorescence spectrum of the Nd:YAG crystal is analysed and the main absorption lines of the Nd-Atoms are verified.
- Finally the half-life of the $4F3/2$ -level is estimated.
- With only a small number of additional components it is possible to build a Nd:YAG laser with this system.

Equipment and technical data

- 1 Flat rail 500 mm with scale
- 1 Laser diode 450 mW in X-Y adjustment holder on carrier
- 1 Control electronics LDS 1200
- 1 Beam shaping optics in holder on carrier
- 1 Beam Focusing in holder on carrier
- 1 Nd:YAG crystal in holder adjustable on carrier
- 1 Filter holder on carrier with filter RG 1000
- 1 Photo detector in holder on carrier and adjustment target
- 3 BNC cables
- 1 IR detector converter screen 800-1200 nm
- 1 Set for optics cleaning
- 1 User manual

08590-93

Nd:YAG laser

P2260900

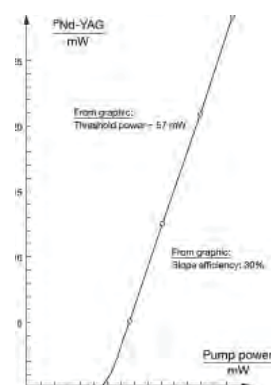

Nd-YAG laser power output as a function of the pump power = 808.4 nm.

Principle

The rate equation model for an optically pumped four-level laser system is determined. As lasing medium, a Nd:YAG (Neodymium-Yttrium Aluminium Garnet) rod has been selected which is pumped by means of a semiconductor diode laser. The IR-power output of the Nd:YAG laser is measured as a function of the optical power input and the slope efficiency as well as the threshold power are determined. Finally, a KTP-crystal is inserted into the laser cavity and frequency doubling is demonstrated. The quadratic relationship between the power of the fundamental wave and the beam power for the second harmonic is then evident.

Tasks

1. Set up the Nd:YAG laser and optimise its power output.
2. The IR-power output of the Nd:YAG laser is to be measured as a function of the pump power. The slope efficiency and the threshold power are to be determined.
3. Verify the quadratic relationship between the power of the fundamental wave, with $\lambda = 1064 \text{ nm}$, and the beam power of the second harmonic with $\lambda = 532 \text{ nm}$.

What you can learn about

- Optical pumping
- Spontaneous emission
- Induced emission
- Inversion
- Relaxation
- Optical resonator
- Resonator modes
- Polarization
- Frequency doubling

Main articles

Basic set optical pumping 08590-93 1

Frequ. doubling crystal in holder	08593-00	1
Nd-YAG laser cavity mirror/holder	08591-01	1
Laser cav.mirror frequ. doubling	08591-02	1
Sensor f. measurem. of beam power	08595-00	1
30 MHz digital storage oscilloscope with colour display, 2 x BNC cables l = 75 cm incl.	11462-99	1
Protection glasses for Nd:Yag laser	08581-20	1



P2261000 Fibre optics

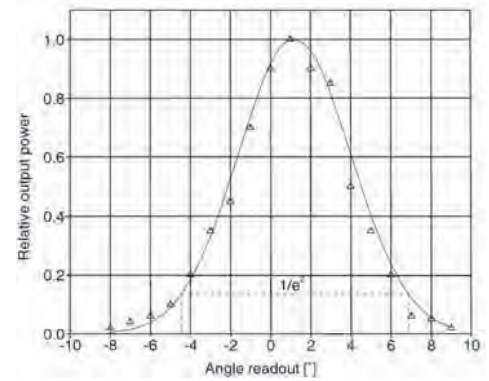

Relative output power at the fibre end versus angle readout.

Principle

The beam of a laser diode is treated in a way that it can be coupled into a monomode fibre. The problems related to coupling the beam into the fibre are evaluated and verified. In consequence a low frequency signal is transmitted through the fibre. The numerical aperture of the fibre is recorded. The transit time of light through the fibre is measured and the velocity of light within the fibre is determined. Finally the measurement of the relative output power of the diode laser as a function of the supply current leads to the characteristics of the diode laser such as "threshold energy" and "slope efficiency".

Tasks

1. Couple the laser beam into the fibre and adjust the setting-up in a way that a maximum of output power is achieved at the exit of the fibre.
2. Demonstrate the transmission of a LF-signal through the fibre.
3. Measure the numerical aperture of the fibre.
4. Measure the transit time of light through the fibre and determine the velocity of light within the fibre.
5. Determine the relative output power of the diode laser as a function of the supply current.

What you can learn about

- Total reflection; Diode laser
- Gaussian beam
- Monomode and multimode fibre
- Numerical aperture
- Transverse and longitudinal modes
- Transit time; Threshold energy
- Slope efficiency; Velocity of light

Main articles

Experimental set Fibre optics	08662-93	1
Digital Storage Oscilloscope 200 MHz, 2-Kanal, 2 GSa/s	11453-99	1
Screened cable, BNC, l 750 mm	07542-11	2



Charles K. Kao
2009, Nobel Prize in Physics



Geo Science

8.1	Water	194
8.2	Air	199
8.3	Soil	201
8.4	X-ray Analysis	204
8.5	Literature	215

P4100160 Comparison of the heat capacities of water and soil (with Cobra4)

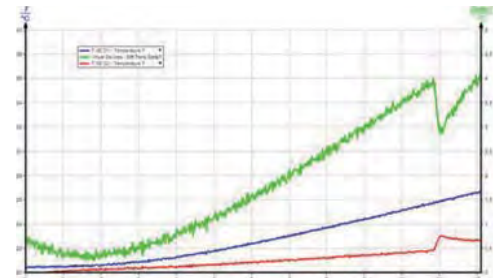

Behaviour of temperature and temperature difference.

Principle

These measurements help to quickly and simply introduce the term "heat capacity". The students learn on which characteristics temperature changes of surfaces depend. As practical example, reference can always be made here to the hot sand at the seaside.

Tasks

1. To prepare comparison curves showing the different heat capacities of water and land.
2. To interpret data on climate and to explain how onshore and offshore wind originate.

What you can learn about

- Heat capacity
- Heat radiation
- Origin of climatic fluctuations
- Generation of onshore and offshore winds

Main articles

Cobra4 Wireless Manager	12600-00	1
Cobra4 Wireless-Link	12601-00	2
Cobra4 Sensor-Unit Temperature, semiconductor -20...110 °C	12640-00	2
Software Cobra4 - multi-user licence	14550-61	1
Ceramic lamp socket E27 with reflector, switch, safety plug	06751-01	1
Sea sand, purified 1000 g	30220-67	1

Cobra4 USB-Link



Function and Applications

The Cobra4 USB-Link is a highly efficient interface module for the transmission of sensor measuring values to a PC via a USB connection.

Benefits

- All Cobra4 Sensor-Units can be connected to the Cobra4 USB-Link using a stable plug-in / lockable connection.
- Up to 400,000 measuring values/sec.
- Several Cobra4 USB links can be connected to one PC (via USB ports on the PC or by USB hub).
- Automatic detection of all Cobra4 Sensor-Units.
- Power supply from USB connection, no additional external power supply required
- ideally suitable for the following applications: Particularly fast measurements (acoustic, electrical etc.); Demonstration experiments; Student's experiments (if one PC is available for each work group)

12610-00

Conductivity of various water samples (with Cobra4)

P4100560



Conductivity of drinking water, depending on its geographic location in and around Göttingen (Germany).

Principle

This experiment shows how much the quality of drinking water of various locations in the same region may vary. The comparison of tap water with bottled mineral water and distilled water leads to surprising results.

Tasks

1. To determine the conductivity of various water samples.
2. To discuss the reasons for the big differences in conductivity.

What you can learn about

- Conductivity of water samples
- Rainwater
- Drinking water
- Aquarium water
- River water
- Mineral water
- Electrolytes waste water
- Eluviation
- Contamination by inorganic salts
- Horizontal/vertical zones

Main articles

Cobra4 USB-Link	12610-00	1
Cobra4 Sensor-Unit Conductivity, with stainless steel electrodes	12633-00	1
Software Cobra4 - multi-user licence	14550-61	1
Reagent bottle,scr.cap,cl.,50ml	46191-00	10

Cobra4 Sensor-Unit Conductivity, with stainless steel electrodes



Function and Applications

The Cobra4 Sensor-Unit Conductivity/Temperature with stainless steel electrodes can be connected directly to the Cobra4 Wireless-Link, the Cobra4 Mobile-Link or the Cobra4 USB-Link using a secure and reliable plug-in / lockable connection.

Benefits

Particularly good application for school and outdoor experimentation, as the measuring gauge is already firmly connected.

12633-00

P4100760 The origin of acid rain (with Cobra4)



Principle

Acid rain is caused by emissions from power plants, households and traffic. Gases such as sulfur dioxide, nitrogen dioxide and carbon dioxide dissolve in rainwater, the products of which form the acids (acids containing sulfur, nitrous acid, nitric acid, carbonic acid). Acid rain reduces the pH of soils and waters. Environmental damage such as forest dieback is the result.

In this experiment acid rain will be produced artificially by adding the gases SO_2 , NO_2 and CO_2 to water. The fall of the pH value is registered.

Task

Drop in pH resulting from the formation of acid then recorded.

What you can learn about

- Acid rain
- Anthropogenic air pollution
- Damage to forests
- Acidification of soil and water
- Gaseous and aerosol emissions

Main articles

Cobra4 USB-Link	12610-00	1
Cobra4 Sensor-Unit pH, BNC connector	12631-00	1
Software Cobra4 - multi-user licence	14550-61	1

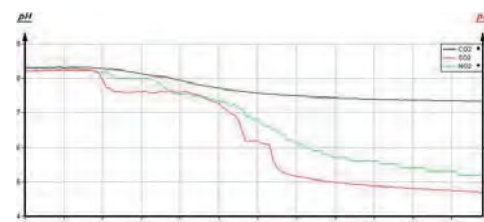

pH time curve for SO_2 , NO_2 and CO_2 .

Cobra4 Sensor-Unit pH, BNC connector



Function and Applications

The Cobra4 Sensor-Unit pH, BNC connection is a measuring recorder for pH measurements, which is controlled by micro-controller.

Benefits

- It can be fitted with a pH probe, in order to measure pH values
- The unit can be connected to the Cobra4 Wireless-Link, the Cobra4 Mobile-Link or the Cobra4 USB-Link using a secure and reliable plug-in / lockable connection.

Equipment and technical data

pH:

- Measuring range: 0...14 pH; Resolution: 0.01 K; Measuring accuracy: $\pm 0.5\%$

General:

- Data flow rate: 5 Hz; Dimensions (mm): 62x63; Weight: 70 g

12631-00

**TESS Cobra4 Environment and outdoors,
with 1 measurement instrument and
english handbook, in aluminum case, BE 1**



Function and Applications

TESS Cobra4 Environment and Outdoors.

Equipment and technical data

The aluminium case for transport and storage contains the following materials:

- 70-page experiment manual
- 1 x Cobra4 Mobile-Link
- 1 x Cobra4 Sensor-Unit pH, BNC connection
- 1 x Cobra4 Sensor-Unit Weather: airpressure, humidity, ambient temperature, brightness
- 1 x Cobra4 Sensor-Unit, Temperature-Semiconductor 20...110 °C
- 1 x Cobra4 Sensor-Unit Conductivity with permanently connected stainless steel
- 1 x pH plastic, gel-filled electrode
- 1 x 100 red pH 4 buffer trays
- 1 x 100 pH 10 green buffer trays
- 1 x 460 ml calibration solution for conductance electrode
- 1 x protective case for GL 25 pH electrode
- 1 x 120 labels
- 4 x 100 ml square flange (HDPE)
- 2 x 250 ml PP laboratory beaker
- 1 x 1 GB 20 MB/sec SD memory card for Cobra4 Mobile-Link
- 1 x 110...240 V Charger for metal hybrid batteries with Mignon 1.2 V 2700 mAh spare batteries
- Delivery incl. CD-ROM with drivers and data analysis software

12619-77

You need more information? **WEB@PHYWE**
Just click www.phywe.com



**Reagent case for water analysis with filter
photometer**



Function and Applications

This excursion case enables students to actively participate in the measurement of water parameters in your immediate neighbourhood. Rapid chemical analyses provide meaningful results in a very short time. The colourimetric tests can be reproducibly and exactly evaluated by using the portable filter photometer.

Benefits

- Compact water laboratory for mobile use with photometer, reagents and accessories in a new robust case with a premium foamed plastic insert
- Increased accuracy and reproducibility by photometric evaluation of colourimetric tests
- Economic refill packs with up to 200 determinations per parameter

Equipment and technical data

- Reagent case with Photometer PF-12 incl. manual and 4 batteries with filters for the following wave lengths: 345 / 436 / 470 / 540 / 585 / 620 / 690 nm
- Software for transferring the measured data to a PC
- Manual with test instructions for test kits
- 4 empty tubes; 1 funnel; 1 beaker 25 ml
- 1 syringe 5 ml; 1 syringe 1 ml
- 1 thermometer, 2 titration syringes with dropping tips
- 2 titration test tubes
- The following test kits: Ammonium, iron, nitrate, nitrite, phosphate, pH, carbonate hardness and total hardness

Accessories

- Ni-MH accumulators, Mignon, 1.2 V, 2000 mAh, Eneloop Type, 4 pcs. (07930-03)
- Fast Charging System for up to 4 Ni-MH accumulators, 100...240 V (07930-99)
- Refill packs of the test kits

30839-00

Ecology case, biological water analysis



Function and Applications

Eco-Kit "Biological testing of water quality". The physical, chemical, and bacteriological examination procedures primarily allow an assessment of the momentary water quality. As the variety of species in a body of water decreases with increasing pollution, and the composition of the organism societies thereby changes, the biological determination of the water quality provides additional important indications on the water quality and allows conclusions to be drawn on the previous pollution. The species and frequency of indicator organisms at various degrees of pollution are thereby coupled to the water quality classes I to IV.

Benefits

- This kit enables 6 working groups to simultaneously carry out examinations of running and standing waters in the field. All important pieces of equipment are present 6-fold.
- The enclosed manual containing tables and sheets for analysis allow assignment to the water quality classes I. ... IV

Equipment and technical data

- Screens
- Trays
- Dishes, large and small
- Tweezers
- Brushes
- Pipettes
- Magnifier glasses, large and small
- Petri dishes
- Dip net for catching aquatic organisms
- Calliper
- Rulers
- Manual with identification key
- Snap lid jars

30834-77

You need more information? **WEB@** PHYWE
Just click www.phywe.com



TESS Biology set chemo-physical water testing



Function and Applications

This kit allows up to 8 work groups to carry out field examinations of running water and lakes.

The following parameters are measured:

- temperature
- oxygen content
- pH-conductivity
- nitrate, nitrite, phosphate and ammonium content
- alkalinity (total hardness)

The examinations can be extended to further parameters when the kit is supplemented with extra equipment, available as accessories and for which room has been reserved in the case:

- depth of transparency (measured using a Secchi disc or a Lux meter with immersion probe)
- water profiles (measurement down to 10 m depth using a water scoop)

The methods are mainly chemo-physical determinations acc. to BACH. They allow an objective assessment of the water quality and are referred to by the Scottish and American Environmental Authorities, as well as those of some German Federal States, in their reports on water quality. The chemo-physical examination methods always give momentary values and so allow measurements of variation over time (daily and seasonal variations) as well as at different positions (e.g. pollution by influents). Added meaning is given by supplementing these methods with biological methods, which aim at the documentation of long-term changes in the condition of the body of water.

Equipment and technical data

The following units are included:

- rapid test for ammonia, pH, nitrate, nitrite, phosphate, oxygen and total hardness
- conductivity tester 0-20 mS/cm, thermometer -10 ... +50 °C
- 500-ml bottles (2x for waste); detailed manual

in the case is also room for:

- Secchi disk (water transparency); water bottles (water profile)
- 2 hand-held instruments according to choice

30837-77

TESS Applied Sciences Set Gas examination



Function and Applications

For investigating air pollution caused by car exhaust gases.

Equipment and technical data

The case contains the following:

- Gas detector pump (100 ml air/stroke)
- Test tube for carbon monoxide
- Sulphur dioxide
- 2x carbon dioxide
- Ozone, nitrous gases
- Benzene and hydrocarbons
- 100-l test bag for exhaust gases with measuring connection, rubber hose and clamp
- Handbook with detailed instructions

30838-77

You need more information?
Just click www.phywe.com

WEB@ PHYWE



TESS Cobra4 Environment and outdoors, with 1 measurement instrument and english handbook, in aluminum case, BE 1



C4

Function and Applications

TESS Cobra4 Environment and Outdoors

Equipment and technical data

The aluminium case for transport and storage contains the following materials:

- 70-page experiment manual
- 1 x Cobra4 Mobile-Link
- 1 x Cobra4 Sensor-Unit pH, BNC connection
- 1 x Cobra4 Sensor-Unit Weather: airpressure, humidity, ambient temperature, brightness
- 1 x Cobra4 Sensor-Unit, Temperature-Semiconductor 20...110 °C
- 1 x Cobra4 Sensor-Unit Conductivity with permanently connected stainless steel
- 1 x pH plastic, gel-filled electrode
- 1 x 100 red pH 4 buffer trays
- 1 x 100 pH 10 green buffer trays
- 1 x 460 ml calibration solution for conductance electrode
- 1 x protective case for GL 25 pH electrode
- 1 x 120 labels
- 4 x 100 ml square flange (HDPE)
- 2 x 250 ml PP laboratory beaker
- 1 x 1 GB 20 MB/sec SD memory card for Cobra4 Mobile-Link
- 1 x 110...240 V Charger for metal hybrid batteries with Mignon 1.2 V 2700 mAh spare batteries
- Delivery incl. CD-ROM with drivers and data analysis software

12619-77

P2140700 Barometric height formula

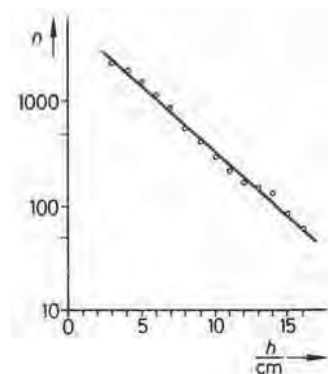

Number of steel balls ($m = 0.034 \text{ g}$), as a function of the height h , which pass through the volume element V in 30 seconds (vibrational frequency 50 Hz).

Principle

Glass or steel balls are accelerated by means of a vibrating plate, and thereby attain different velocities (temperature model). The particle density of the balls is measured as a function of the height and the vibrational frequency of the plate.

Tasks

Measurement of the particle density as a function of:

1. the height, at fixed frequency.
2. the vibrational frequency of the exciting plate, at fixed height.

What you can learn about

- Kinetic gas theory
- Pressure
- Equation of state
- Temperature
- Gas constant

Main articles

Kinetic gas theory apparatus	09060-00	1
Digital stroboscope	21809-93	1
Power supply variable 15 VAC/ 12 VDC/ 5 A	13530-93	1
Light barrier with counter	11207-30	1
Tripod base PHYWE	02002-55	2
Power supply 5 V DC/2.4 A with 4 mm plugs	11076-99	1
Stopwatch, digital, 1/100 s	03071-01	1

Kinetic gas theory apparatus



Function and Applications

Kinetic gas theory apparatus with vertical chamber and built in motor.

Equipment and technical data

- Chamber (mm) 60 x 20 x 180
- Motor supply 12 VDC /20 W

09060-00

Salinity of soils and plant substrates (with Cobra4)

P1521163



Setup for an additional experiment.

Principle

Demonstration experiment using wireless data communication to send readings to a large-size display. How suitable are certain soils and plant substrates in terms of plant nutrition? This experiment is concerned with the measurement of conductivity, which gives an indication of which of the studied soils and plant substrates already contain nutrient salts necessary for the growth of plants and which ones would be better if nutrients were added in the form of fertiliser. Plants gain their nutrition in the form of salt ions from the soil. The most important of the 16 nutrients which plants need to grow are nitrogen in the form of nitrates and ammonia, phosphorus in the form of phosphates and potassium in the form of potassium salts. In addition, soils need to have lime (calcium carbonate) to reduce their acidity (reduction in pH). For agricultural purposes, such nutrients are added to the soil in the form of inorganic fertilisers. For house plants, fertiliser-enriched potting soil is used.

Task

Measure the conductivity of the samples in the supernatant and note the values.

What you can learn about

- Conductivity; Salinity
- Acidity; Inorganic fertilisers

Main articles

Cobra4 Display-Connect, Set of transmitter and receiver for using the Cobra4 Mobile-Link with large-scale displays	12623-88	1
Cobra4 Mobile-Link set, incl. rechargeable batteries, SD memory card, USB cable and software "measure"	12620-55	1

Cobra4 Sensor-Unit Conductivity, with stainless steel electrodes	12633-00	1
Large-scale display, digital, RS-232 port	07157-93	1
Portable Balance, OHAUS JE120	48895-00	1

Cobra4 Display-Connect, Set of transmitter and receiver for using the Cobra4 Mobile-Link with large-scale displays



Function and Applications

Device combination from a sender and a receiver for the radio-based communication between a Cobra4 Mobile Link and up to 2 digital large displays.

12623-88

P1521063 The pH value of various soils (with Cobra4)

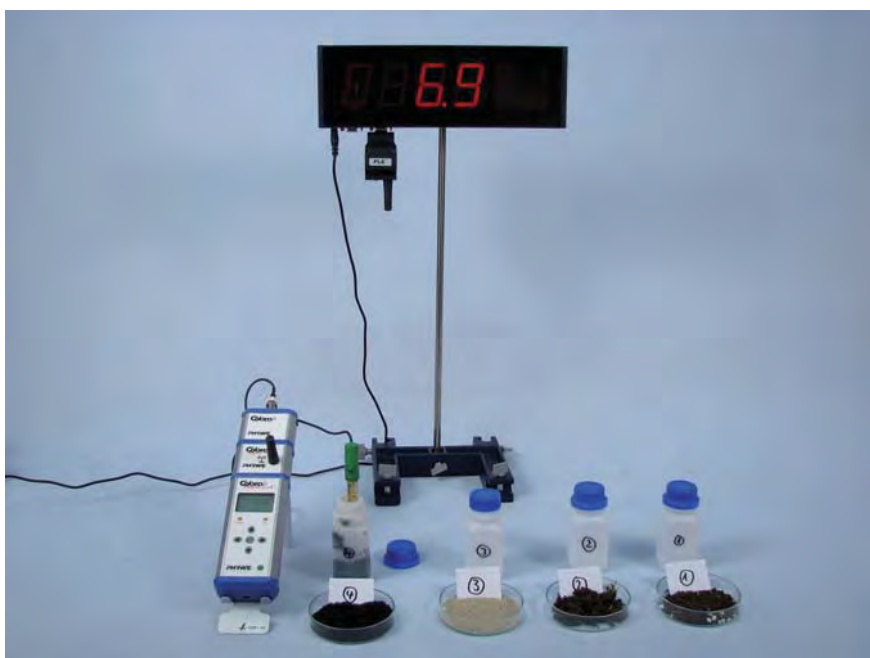

Ground profile of luvisol on loess (with three measuring points).

Principle

Demonstration experiment using wireless data communication to send readings to a large-size display. Knowledge of soil characteristics is highly important for agriculture. To familiarise students with this topic, two sub-experiments use pH readings to demonstrate how different soils from different places can be (sub-experiment "Characteristic pH values for soils") and how varied the soil can be down below the surface (sub-experiment "Soil profiles").

Tasks

1. Determine the characteristic pH values of various soil samples.
2. Investigate the soil profile of your area.

What you can learn about

- Acidity of soils
- pH value
- Substratum
- Soil horizon

Main articles

Cobra4 Mobile-Link set, incl. rechargeable batteries, SD memory card, USB cable and software "measure"	12620-55	1
Cobra4 Sensor-Unit pH, BNC connector	12631-00	1
pH-electrode, plastic body, gel, BNC	46265-15	1
Buffer solution tablets pH4, 100	30281-10	1
Buffer solution tablets pH10, 100	30283-10	1

Cobra4 Mobile-Link set, incl. rechargeable batteries, SD memory card, USB cable and software "measure"



Function and Applications

The Cobra4 Mobile-Link is a modern, high performance hand measuring device for mobile data recording, to which all Cobra4 Sensor-Units can be connected via secure plug-in/ lockable connection.

Benefits

- Up to 1,000 measuring values/sec
- Data can be saved on an SD memory card
- Automatic detection of all Cobra4 Sensor-Units
- Foolproof navigation with central navigation cross
- "measure" evaluation software can be used for FREE
- Water-resistant and reliable for outdoor work

12620-55

TESS Applied Sciences set examination of soil



Function and Applications

The case includes accessories and reagents to field-test soil on: mineral matter, body of humus, water/air, soil structure, acidity, nutrients, soil life.

The 60-page manual describes 19 soil analysis methods and includes an exhaustive theoretical treatise on the following topics:

- basic principles of soil science
- soil as a site factor in forests
- soil fertility factors
- changes in the soil

30836-77



Soil Analysis

Excursion set, soil analysis



Function and Applications

The case contains the complete equipment for the determination of the type of soil, the soil structure, the pH of the soil and its nutrient content, i.e. the nitrogen, phosphate and potassium content available to plants.

Benefits

- The manual contains detailed descriptions of experiments for determining soil characteristics
- It contains a complete schedule for soil testing, from taking samples to differentiating the various soil types, from the determination of the nutrient content to the calculation of the amount of fertiliser required
- It also supplies valuable background information
- All necessary reagents, equipment and accessories are clearly positioned in the case, so that a glance suffices to check that it is complete

Equipment and technical data

- Extraction solutions; Balance
- 2 scoops; 3 syringes; Pleated filter
- Colander; Spray bottle; 5 containers
- 2 cylinders; 2 funnels; Blades; Spoon

Accessories

- Soil auger (64221-01) or Soil auger, small (64222-00)

30346-00

TESS Cobra4 Environment and outdoors, with 1 measurement instrument and english handbook

12619-77

XRE 4.0 expert set – Details at a glance

Experience the perfect synthesis of innovative technology, highest level of safety, well-proven PHYWE quality and modern design. Extensive performance characteristics and ideas make working with the PHYWE XR 4.0 a special experience. We have presented some device highlights for you here.

Tube XChange Technology

- Self-adjusting X-ray tubes with quick-change technology
- Contact protection against hot parts
- 4 anode materials for specific experiments (W, Mo, Cu, Fe)



Touch Panel

- Simultaneous control, manually and by computer
- Interactive, intuitive handling
- Self-explanatory icons for fast operation

3View – Insight provides a transparent view

- Exceptional observability of the experimentation space
- Extra-large window front on 3 sides (Diagonals: 18"/18"/14", 46cm/46cm/36cm)



XXL Chamber

- Large space for large experiments
- Temperature-controlled, internally-ventilated experimentation space



Optical bench with riders

- Radiography experiments
- Simple, precise positioning of optical components



S-Lock – new PHYWE Safety interlock

- Electrical and mechanical safety lock
- Prevents door opening with switched on X-radiation
- Thus offers the highest possible safety
- Patent pending

Goniometer (not pictured)

- Self-calibrating
- Collision protected
- Easy, safe handling



MultiLINK

- Connection field internal and external
- USB 2.0, N₂, BNC, XRED, Aux, etc.
- No annoying „cable-laying“
- In addition, extra-large cable conduit

High-resolution TFT backlit display

- Diagonal 4.3“
- 480 x 272 Pixel
- 16 Bit, 65.536 colors
- With LED lighting
- Optimal, dynamic representation of all important device parameters and measured values

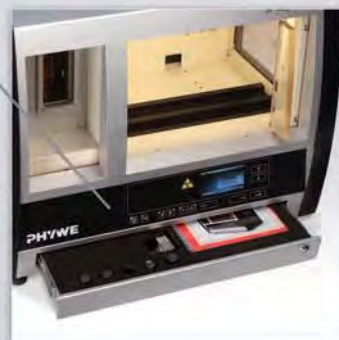

Safekeeping drawer

- All accessories are kept safely and always ready at hand
- Lockable

XR 4.0 expert unit – Sets for all applications

Basic set	Core components (incl. further Accessories)	Areas of application	Application examples
XR 4.0 expert set Art. No. 09110-88 (Basic set)	<ul style="list-style-type: none"> ■ XR 4.0 expert unit (X-ray device) ■ Tungsten tube (W) ■ XR measure 4.0 X-ray software ■ Optical bank ■ TESS expert manual ■ Fluorescent screen ■ USB cable, mains cable + adaptor 		<ul style="list-style-type: none"> ■ Basics & applications of X-radiation ■ Radiographic experiments ■ Radiology

Extend the basic set with the respective extension set according to area of application

Extension sets (optional)	Core components (incl. further accessories)	Areas of application	Application examples
XRP 4.0 solid-state physics Art. No. 09120-88	<ul style="list-style-type: none"> ■ Goniometer, GM counter tube ■ LiF / KBr single crystal ■ Absorption set 		<ul style="list-style-type: none"> ■ Diffractometry ■ X-ray spectroscopy ■ Bragg-reflection / Bremsstrahlung spectrum ■ Characteristic lines
XRC 4.0 characterisation Art. No. 09130-88	<ul style="list-style-type: none"> ■ 3 X-ray tubes (Cu, Fe, Mo) ■ Goniometer, GM counter tube ■ LiF / KBr single crystal 		<ul style="list-style-type: none"> ■ Radiation spectrums of the anode ■ Moseley law ■ Rydberg constant ■ Duane-Hunt law
XRS 4.0 structure analysis Art. No. 09140-88	<ul style="list-style-type: none"> ■ Goniometer, GM counter tube ■ LiF / KBr / NaCl single crystal ■ Crystal holder ■ Powder samples 		<ul style="list-style-type: none"> ■ Structure investigations ■ Laue patterns ■ Debye-Scherrer recordings ■ X-ray analysis
XRM 4.0 material analysis Art. No. 09160-88	<ul style="list-style-type: none"> ■ Goniometer ■ X-ray energy detector ■ Multi channel analyser ■ Sample sets 		<ul style="list-style-type: none"> ■ X-ray fluorescence spectroscopy ■ Non-destructive testing (NDT) ■ Compton Effect ■ Energy-dispersive experiments
XRI 4.0 radio photography Art.-No. 09150-88	<ul style="list-style-type: none"> ■ Camera ■ Radiographic object ■ Model loader ■ Implant model 		<ul style="list-style-type: none"> ■ Basics for the X-ray image provision ■ Radiography ■ Radiology ■ Non-destructive testing (NDT)
XRD 4.0 dosimetry and radiation damage Art. No. 09170-88	<ul style="list-style-type: none"> ■ Parallel-plate capacitor ■ Power supply unit 600 V ■ DC current amplifier ■ Camera 		<ul style="list-style-type: none"> ■ Dosimetry ■ Degradation ■ Damage ■ Ionisation of air
XRCT 4.0 computer tomography Art. No. 09180-88	<ul style="list-style-type: none"> ■ Direct, digital X-ray image sensor ■ Rotation unit, vertical rotation ■ measure Tomography software package 		<ul style="list-style-type: none"> ■ 3-dimensional reconstruction ■ Sectional drawings in respective position ■ Direct, digital image provision
XRW 4.0 wireless demonstration Art. No. 09115-88	<ul style="list-style-type: none"> ■ Digital display panel ■ Cobra4 Display-Connect ■ Transmitter and receiver, etc. 		<ul style="list-style-type: none"> ■ Demonstration experiments (operation without computers) ■ Placard-style representation of the measured values and parameters

Examination of the structure of NaCl monocrystals with different orientations

P2541301

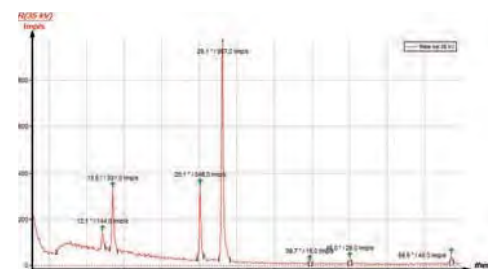

Intensity of the X-ray spectrum of copper as a function of the glancing angle theta: NaCl monocrystals with [111] crystal orientation as Bragg analyser.

Principle

The spectra of the X-rays that are reflected with various different orientations by NaCl monocrystals are analysed. The associated interplanar spacings are determined based on the Bragg angles of the characteristic lines.

Tasks

1. Determine the intensity of the X-rays that are reflected by the NaCl monocrystals with the orientations [100], [110], and [111] as a function of the Bragg angle.
2. Assign the reflections to the corresponding lattice planes that are given by way of their respective Miller indices.
3. Determine the lattice constant and calculate the interplanar spacing.
4. Determine the mass of a cell and the number of atoms in the cell.

What you can learn about

- Characteristic X-radiation
- Energy levels
- Crystal structures
- Reciprocal lattices
- Miller indices
- Atomic form factor
- Structure factor
- Bragg scattering

Main articles

XR 4.0 expert unit	09057-99	1
XR 4.0 X-ray goniometer	09057-10	1
XR 4.0 X-ray Plug-in Cu tube	09057-50	1
XR 4.0 X-ray NaCl-monocrystals, set of 3	09058-01	1
XR 4.0 Software measure X-ray	14414-61	1
Geiger-Mueller Counter tube, type B	09005-00	1

Best fitting X-ray sets for this experiment:

XR 4.0 X-ray expert set

09110-88

XRS 4.0 X-ray structural analysis upgrade set

09140-88

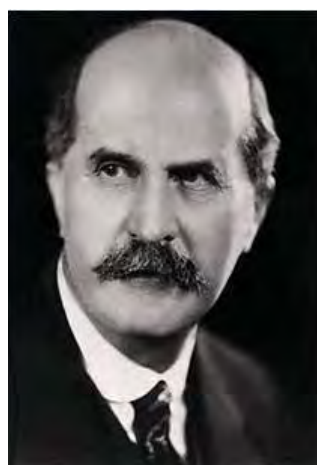

Sir William Henry Bragg (left) and Sir William Lawrence Bragg (right)
1915, Nobel Prize in Physics

P2541401 X-ray investigation of cubic crystal structures / Debye- Scherrer powder method

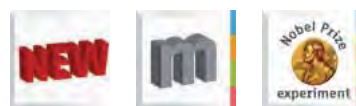

Debye-Scherrer pattern of a powdered sample of NaCl. Thickness of the sample: 0.4 mm. Exposure time: 2.5 h. Mo X-ray tube: $U_a = 35$ kV; $I_a = 1$ mA

Principle

When polycrystalline samples are irradiated with X-rays a characteristic diffraction pattern results. These Debye-Scherrer reflections are photographed and then evaluated.

Tasks

1. Debye-Scherrer photographs are to be taken of powdered samples of sodium chloride and caesium chloride.
2. The Debye-Scherrer rings are to be evaluated and assigned to the corresponding lattice planes.
3. The lattice constants of the sample materials are to be determined.
4. The number of atoms in the unit cells of each sample are to be determined.

What you can learn about

- Crystal lattices
- Crystal systems
- Reciprocal lattice
- Miller indices
- Structure amplitude
- Atomic form factor
- Bragg scattering

Main articles

XR 4.0 expert unit	09057-99	1
XR 4.0 X-ray Plug-in Mo tube	09057-60	1
XR 4.0 X-ray film holder	09057-08	1
XR 4.0 X-ray optical bench	09057-18	1
XR 4.0 X-ray films, wet chemical, 100 pieces, 100 × 100 mm	09058-23	1
XR 4.0 X-ray Diaphragm tube d = 1 mm	09057-01	1

Slide mount for optical bench, h = 30 mm 08286-01 1

Related Experiment

X-ray investigation of hexagonal crystal structures / Debye-Scherrer powder method

P2541501

Best fitting X-ray sets for this experiment:

XR 4.0 X-ray expert set

09110-88

XRS 4.0 X-ray structural analysis upgrade set

09140-88

X-ray investigation of crystal structures / Laue method with digital X-ray image sensor (XRIS)

P2541602

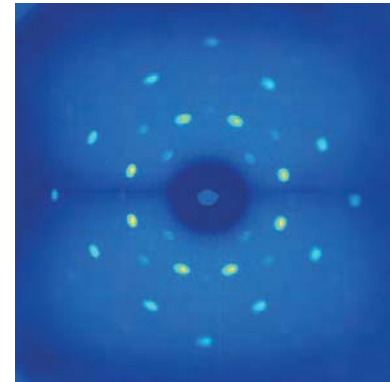

Laue pattern of the LiF (100) crystal.

Principle

Laue diagrams are produced when monocrystals are irradiated with polychromatic X-rays. This method is primarily used for the determination of crystal symmetries and the orientation of crystals. When a LiF monocrystal is irradiated with polychromatic X-rays, a characteristic diffraction pattern results. This pattern is photographed with the digital X-ray sensor XRIS.

Tasks

1. The Laue diffraction of an LiF mono-crystal is to be recorded on a film.
2. The Miller indices of the corresponding crystal surfaces are to be assigned to the Laue reflections

What you can learn about

- Crystal lattices; Crystal systems; Crystal classes
- Bravais lattice; Reciprocal lattice; Miller indices
- Structure amplitude; Atomic form factor; The Bragg equation

Main articles

XR 4.0 X-ray Direct Digital Image Sensor (XRIS) with USB cable	09057-40	1
XR 4.0 expert unit	09057-99	1
XR 4.0 Software measure CT	14421-61	1
XR 4.0 X-ray plug-in unit W tube	09057-80	1
XR 4.0 X-ray Lithium fluoride crystal, mounted	09056-05	1
XR 4.0 X-ray optical bench	09057-18	1
XR 4.0 X-ray Crystal holder for Laue-pattern	09058-11	1

Related X-ray Experiment

X-ray investigation of crystal structures / Laue method

P2541601

Best fitting X-ray sets for this experiment:

XR 4.0 X-ray expert set

09110-88

XRCT 4.0 X-ray Computed Tomography upgrade set

09180-88

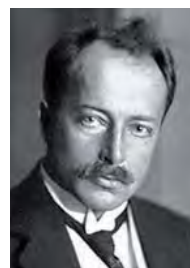

Max von Laue

1914, Nobel Prize in Physics

P2544701 Qualitative X-ray fluorescence analysis of powder samples

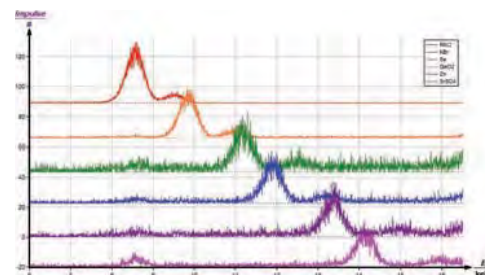

Total representation of the $K\alpha$ and $K\beta$ fluorescence lines of the elements with an atomic number of $30 < Z < 38$.

Principle

Various powder samples are subjected to polychromatic X-rays. The energy of the resulting fluorescence radiation is analysed with the aid of a semiconductor detector and a multichannel analyser. The energy of the corresponding characteristic X-ray fluorescence lines is determined. The elements of the samples are identified by comparing the line energies with the corresponding table values.

Tasks

1. Calibrate the semiconductor energy detector with the aid of the characteristic radiation of the tungsten X-ray tube.
2. Record the fluorescence spectra that are produced by the samples.
3. Determine the energy values of the corresponding fluorescence lines and compare the experimental energy values with the corresponding table values in order to identify the powder components.

What you can learn about

- Bremsstrahlung; Characteristic X-radiation
- Energy levels; Fluorescent yield
- Semiconductor energy detectors
- Multichannel analysers

Main articles

XR 4.0 expert unit	09057-99	1
XR 4.0 X-ray energy detector (XRED)	09058-30	1
XR 4.0 X-ray goniometer	09057-10	1
XR 4.0 X-ray plug-in unit W tube	09057-80	1
Multi channel analyser	13727-99	1
XR 4.0 X-ray Chemical set for edge absorption	09056-04	1
measure Software multi channel analyser	14452-61	1

Multi channel analyser



Function and applications

The multi channel analyser is for analysing voltage pulses which are proportional to energy and for determining pulse rates and intensities in conjunction with an X-ray detector, alpha detector or gamma detector. The analogue pulses from the detector are shaped by the analyser, digitised and summed per channel according to pulse height. This results in a frequency distribution of detected pulses dependent on the energy of the radiation.

13727-99

Best fitting X-ray sets for this experiment:

XR 4.0 X-ray expert set

09110-88

XR 4.0 X-ray material analysis upgrade set

09160-88

Quantitative X-ray fluorescence analysis of alloyed materials

P2545001

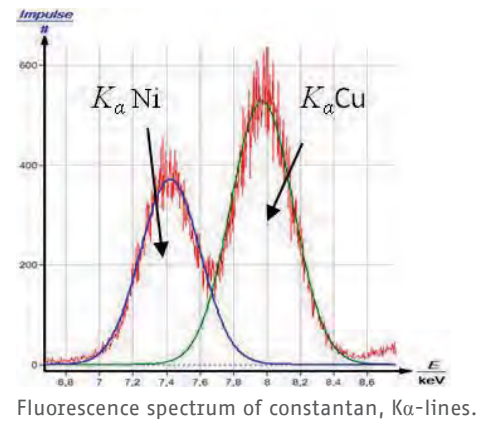

Principle

Various alloyed materials are subjected to polychromatic X-rays. The energy of the resulting fluorescence radiation is analysed with the aid of a semiconductor detector and a multichannel analyser. The energy of the corresponding characteristic X-ray fluorescence lines is determined. In order to determine the concentration of the alloy constituents, the intensity of their respective fluorescence signals is compared to that of the pure elements.

Tasks

1. Calibration of the semiconductor energy detector with the aid of the characteristic radiation of the tungsten X-ray tube.
2. Recording of the fluorescence spectra that are produced by the alloyed samples.
3. Recording of the fluorescence spectra that are produced by the pure metals.
4. Determination of the energy values of the corresponding fluorescence lines.
5. Calculation of the concentration levels of the alloy constituents.

What you can learn about

- Bremsstrahlung; Characteristic X-radiation
- Energy levels; Fluorescent yield; Auger effect
- Coherent and incoherent photon scattering
- Absorption of X-rays; Edge absorption
- Matrix effects; Semiconductor energy detectors
- Multi channel analysers

Main articles

XR 4.0 expert unit	09057-99	1
XR 4.0 X-ray energy detector (XRED)	09058-30	1
XR 4.0 X-ray goniometer	09057-10	1
XR 4.0 X-ray plug-in unit W tube	09057-80	1
Multi channel analyser	13727-99	1

XR 4.0 X-ray specimen set metals for fluorescence, set of 4	09058-34	1
XR 4.0 X-ray specimen set metals for X-ray fluorescence, set of 7	09058-31	1

XR 4.0 X-ray energy detector (XRED)



Function and Applications

With the new X-ray energy detector you can directly determine the energies of single x-ray quanta.

09058-30

Best fitting X-ray sets for this experiment:

XR 4.0 X-ray expert set

09110-88

XR 4.0 X-ray material analysis upgrade set

09160-88

P2544901 Qualitative X-ray fluorescence analysis of ore samples

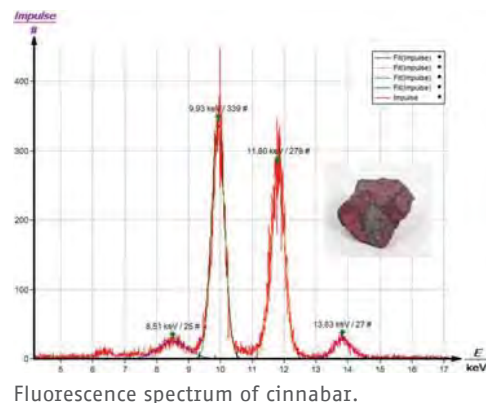

Principle

Various ore samples are subjected to polychromatic X-rays. The energy of the resulting fluorescence radiation is analysed with the aid of a semiconductor detector and a multichannel analyser. The energy of the corresponding characteristic X-ray fluorescence lines is determined. The elements of the samples are identified by comparing the line energies with the corresponding table values.

Tasks

1. Calibrate the semiconductor energy detector with the aid of the characteristic radiation of the tungsten X-ray tube.
2. Record the fluorescence spectra that are produced by the samples.
3. Determine the energy values of the corresponding fluorescence lines and compare the experimental energy values with the corresponding table values in order to identify the ore samples.

What you can learn about

- Bremsstrahlung
- Characteristic X-radiation
- Energy levels
- Fluorescent yield
- Semiconductor energy detectors
- Multichannel analysers

Main articles

XR 4.0 expert unit	09057-99	1
XR 4.0 X-ray energy detector (XRED)	09058-30	1
XR 4.0 X-ray goniometer	09057-10	1
XR 4.0 X-ray plug-in unit W tube	09057-80	1
Multi channel analyser	13727-99	1
Ores collection, 40 ores	39782-00	1
measure Software multi channel analyser	14452-61	1

XR 4.0 X-ray goniometer



Function and Applications

Goniometer with two independent stepper motors for the precise angular positioning of a sample and detector.

Benefits

Self-calibrating goniometer

Plug & measure:

- Automatic identification of the goniometer
- Goniometer block with two independent stepper motors for rotating the sample holder and the detector either separately or coupled in a 2:1 ratio
- The detector holder with a slit diaphragm holder for absorption foils can be moved in order to change the angular resolution
- Includes a light barrier system for limiting the permissible swivelling range and, thereby, for protecting the detectors
- Intuitive operation directly at the unit or via a PC

09057-10

Qualitative X-ray fluorescence spectroscopy of metals - Moseley's law

P2544501

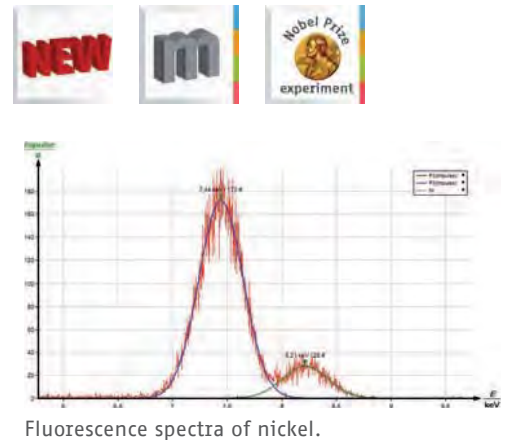

Principle

Various metal samples are subjected to polychromatic X-rays. The energy of the resulting fluorescence radiation is analysed with the aid of a semiconductor detector and a multi-channel analyser. The energy of the corresponding characteristic X-ray lines is determined, and the resulting Moseley diagram is used to determine the Rydberg frequency and the screening constants.

Tasks

1. Calibrate the semiconductor energy detector with the aid of the characteristic radiation of the tungsten X-ray tube.
2. Record the spectra of the fluorescence radiation that are generated by the metal samples.
3. Determine the energy values of the corresponding characteristic $K\alpha$ - and $K\beta$ -lines.
4. Determine the Rydberg frequency and screening constants with the aid of the resulting Moseley diagrams.

What you can learn about

- Bremsstrahlung; Characteristic X-radiation
- Absorption of X-rays; Bohr's atom model
- Energy levels; Moseley's law; Rydberg frequency
- Screening constant; Semiconductor energy detectors
- Multi-channel analysers

Main articles

XR 4.0 expert unit	09057-99	1
XR 4.0 X-ray energy detector (XRED)	09058-30	1
XR 4.0 X-ray goniometer	09057-10	1
XR 4.0 X-ray plug-in unit W tube	09057-80	1
Multi channel analyser	13727-99	1
XR 4.0 X-ray Specimen set metals for X-ray fluorescence, set of 7	09058-31	1
measure Software multi channel analyser	14452-61	1



Quantitative X-ray fluorescence analysis of solutions

P2545101



Principle

Various solutions, with known element concentrations, are subjected to polychromatic X-rays. The energy and intensity of the resulting fluorescence radiation of the dissolved elements are analysed with the aid of a semiconductor detector and a multichannel analyser. In order to determine the unknown element concentrations in the solutions, calibration is performed. For this purpose, the known element concentrations of the calibration solution are plotted against the corresponding fluorescence intensities of the dissolved elements.

For more details refer to www.phywe.com

Qualitative X-ray fluorescence analysis of alloyed materials

P2544601



Principle

The composition of various alloys is analysed with the aid of polychromatic X-rays. The energy of the characteristic fluorescence lines of the alloy constituents is analysed with the aid of a semiconductor detector and a multichannel analyser. The alloy constituents are identified by comparing the line energies with the corresponding table values.

For more details refer to www.phywe.com

You need more information?
Just click www.phywe.com

WEB @ PHYWE



**TESS advanced Applied Sciences manual
Cobra4 environment and outdoors**



Article no. 12622-02

Description

Experimental descriptions from the fields of environment and outdoors that pay particular attention to the advantages of data acquisition with the Cobra4 Mobile-Link. In total more than 15 demonstration and student experiments are described in detail.

Topics

- Learning stations using the experimentation case "Environment and Outdoors"
- We examine our drinking water
- Acidity changes of a watercourse
- Salinity changes of a watercourse
- Water quality - heavy metal pollution
- Salinity of soils and plant substrates
- Acidity of soils
- Raised bogs and fens
- Comparison of soil and air temperature during the course of a day
- Weather observation
- Changes of the light conditions in a deciduous forest
- Altitude measurement on a trail
- Measurement of the height of a tower
- Terrain mapping
- Air pressure and relative humidity in a plane
- We visit a wastewater treatment plant

Equipment and technical data

DIN A4 stapled, colour, 80 pages

This documentation contains the following experiments:

Water quality - contamination with heavy metals
P0990162

We examine our drinking water
P1520062

Altitude measurement on a trail
P1520262

Measuring the height of a tower
P1520362

Weather observation with the Cobra4 Mobile-Link
P1520462

Terrain mapping
P1520662

Changes of the light conditions in a deciduous forest
P1520762

Acidity changes of a watercourse
P1520862

Comparison of soil and air temperatures in the course of a day
P1520962

The pH value of various soils
P1521062

Salinity of soils and plant substrates
P1521162

Raised bog and fen
P1521262

Air pressure and relative humidity in an aircraft
P1521362

Salinity changes of a watercourse
P1521462

Learning stations using the experimentation case "Cobra4 Mobile, Environment and outdoors"
P1521562

We visit a wastewater treatment plant
P1521662

Complete experiment list see www.phywe.com

12622-02

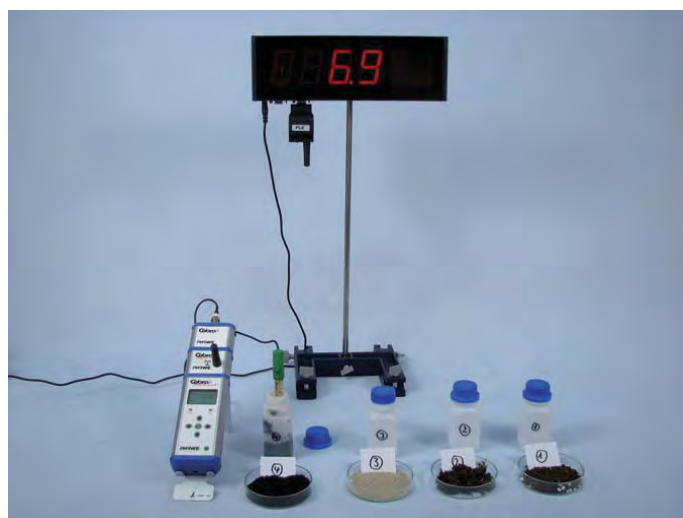

P1521063 - The pH value of various soils

Handbook Physics X-Ray Experiments

**Article no. 01200-02**

Experiments with X-rays and their use in physics, chemistry, biology, medicine, material science, and geology

Description

Comprehensive collection of reference experiments concerning the fundamental principles and use of X-rays in physics, chemistry, biology, medicine, material science, and geology with the XR 4.0 X-ray unit platform as a pool of ideas concerning the potential areas of application in demonstration and laboratory experiments. A clear matrix simplifies the orientation in terms of scientific fields and topics.

Topics

- Characteristic X-radiation / atomic structure / quantum physics and chemistry
- X-ray absorption
- Compton scattering
- Dosimetry
- Crystal structures/structural analysis with X-rays/Debye-Scherrer experiments (counting tube goniometer)
- Transirradiation experiments/non-destructive testing

Features

- Experiment descriptions with clearly structured learning objectives, fundamental principles, photo of the set-up, equipment list, tasks, illustrated instructions concerning the set-up and procedure, theory and evaluation with example results plus important notes concerning the operation and safety of the equipment. This simplifies the orientation and execution as well as the selection of the experiment parts for personalised laboratory experiments. The information provided is so comprehensive that no other background information is required.
- For every experiment, the software package "XRM 4.0 measure X-ray" includes presettings for the easy and direct execution of the experiment at the push of a button as well as numerous example measurements.
- Experiment matrix for quick orientation
- Operating instructions concerning the components of the XR 4.0 platform including detailed information
- DIN A4 format, spiral-bound
- Colour print

This documentation contains the following experiments:

Counter tube characteristics

P2540010

Radiographic examination of objects

P2540020

Qualitative examination of the absorption of X-rays

P2540030

Ionizing effect of X-radiation

P2540040

Characteristic X-rays of copper

P2540101

Characteristic X-rays of iron

P2540301

The intensity of characteristic X-rays as a function of the anode current and anode voltage

P2540401

Monochromatisation of molybdenum X-rays

P2540501

Monochromatisation of copper X-rays

P2540601

K alpha double splitting of molybdenum X-rays/ fine structure

P2540701

K alpha doublet splitting of iron X-rays / fine structure

P2540801

Duane-Hunt displacement law and Planck's "quantum of action"

P2540901

Characteristic X-ray lines of different anode materials / Moseley's law

P2541001

Absorption of X-rays

P2541101

Complete experiment list see: www.phywe.com

01200-02

P2541801 - X-ray dosimetry



About PHYWE

9.1	Company profile	218
9.2	Nobel Prize Experiments	220
9.3	Computer Assisted Measurement	222
9.4	Lucas-Nülle Group	226
9.5	Safety Instructions	228
9.6	General terms and conditions	231

Traditional yet modern 100 years of quality

Those who know nothing must believe everything.

Marie von Ebner-Eschenbach

With a 100-year tradition of excellence, PHYWE Systeme GmbH & Co. KG stands for technical capability, innovation, quality and customer satisfaction. As a leading supplier of premium quality teaching and learning materials, PHYWE is one of the world's largest providers of system solutions for the instruction of the natural sciences.

The product range comprises scientific equipment, experiments and solution systems along with modern blended learning systems, literature and software for the areas of physics, chemistry, biology, medicine, material science and earth science. A broad spectrum of services such as training programmes, installation and comprehensive consulting services completes the portfolio.

PHYWE solutions can be individually adapted to the specific curricula in each country and provide ideal coverage for the full spectrum of performance specifications and requirements. Ask us to prepare a customised equipment offering to suit your special needs!





PHYWE supplies more than 50 Nobel Prize awarded experiments

The Nobel Prize is awarded annually in the disciplines of physics, chemistry, physiology or medicine, literature and peace. For scientists and researchers, it is the highest award.

PHYWE supplies more than 50 Nobel Prize awarded experiments. From Conrad Röntgen to Max Planck or Albert Einstein. Experiments in the footsteps of Nobel Prize winners. PHYWE made Nobel Prize experiments understandable.

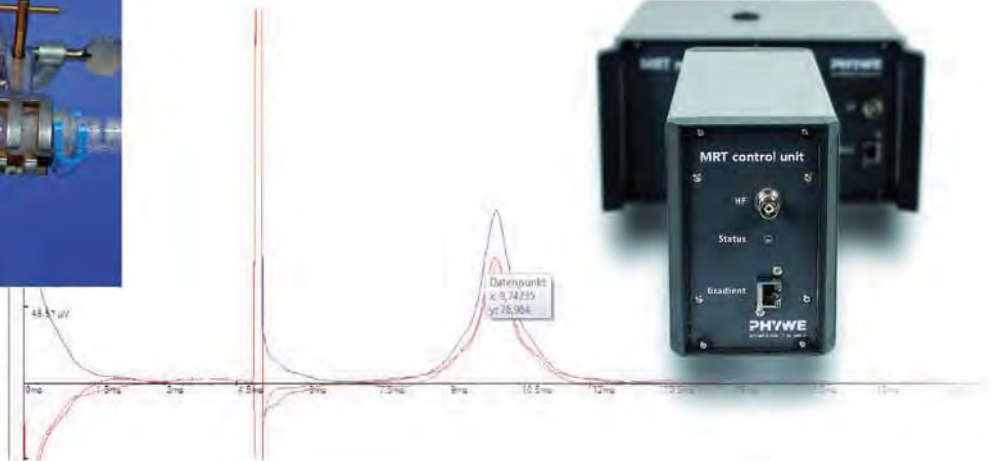

Nobel Prize awarded experiments (Selection)

1900 ...

- 1901 – Wilhelm Conrad Röntgen
- 1901 – Jacobus Henricus van 't Hoff
- 1902 – Hendrik A. Lorentz,
Pieter Zeeman
- 1903 – Henri Becquerel, Pierre Curie,
Marie Curie
- 1908 – Ernest Rutherford
- 1909 – Wilhelm Ostwald

1910 ...

- 1910 – Johannes Diderik van der Wals
- 1914 – Max von Laue
- 1915 – Sir William Henry Bragg,
Sir William Lawrence Bragg
- 1912 – F. A. Victor Grignard
- 1918 – Fritz Haber

1920 ...

- 1921 – Albert Einstein
- 1922 – Niels Bohr, Henrik David
- 1924 – Manne Siegbahn
- 1924 – Willem Einthoven
- 1925 – James Franck, Gustav Hertz

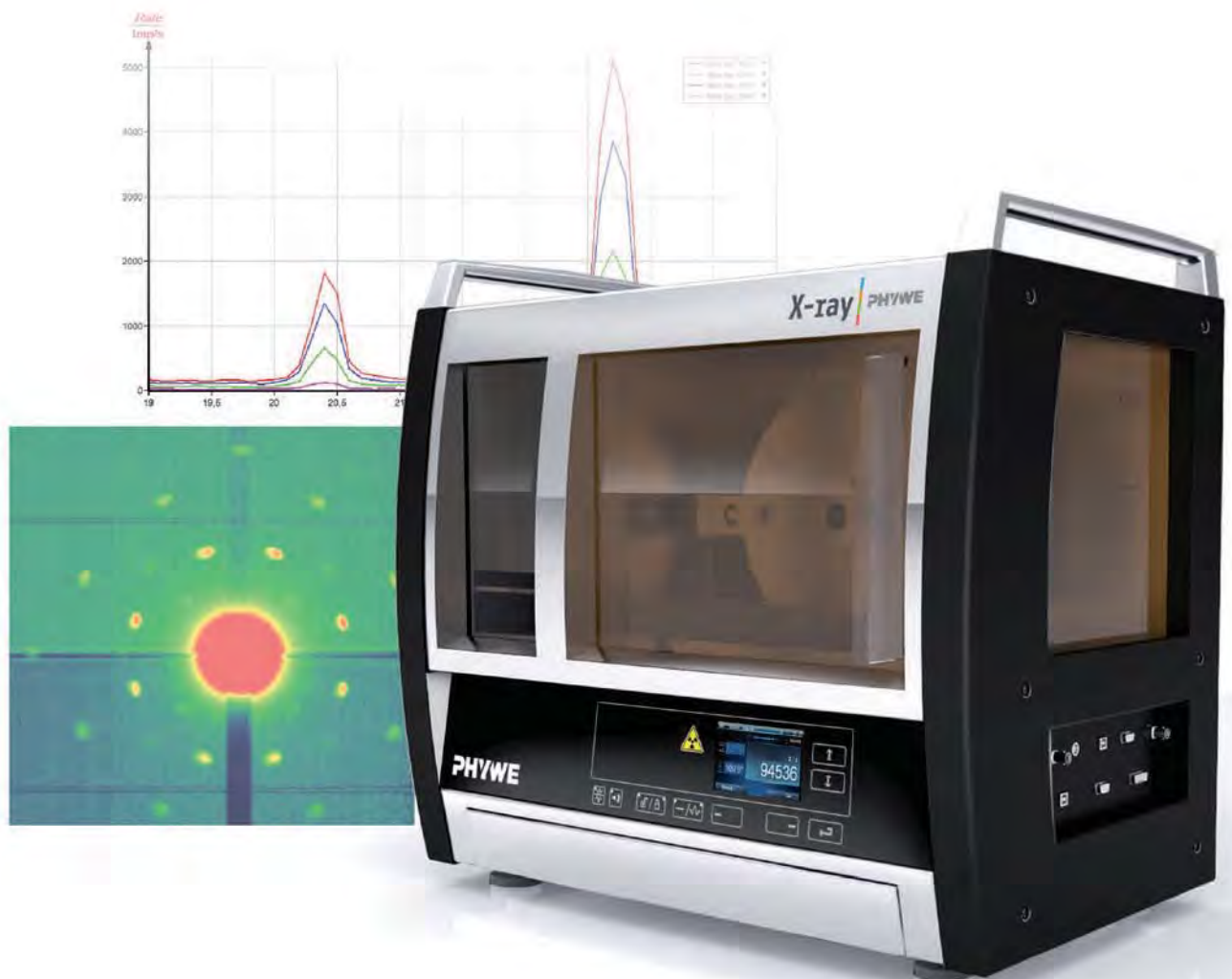

1930 ...

1931 – Carl Bosch, Friedrich Bergius

1932 – Irving Langmuir

1936 – Victor Franz Hess,
Carl David Anderson

1936 – Peter Josephus W. Debye

1940 ...

1943 – Otto Stern

1952 – Felix Bloch, Edward M. Purcell

1952 – Archer John P. Martin,
Richard Laurence M. Synge

1954 – Max Born, Walther Bothe

1970 until today

1971 – Dennis Gabor

1979 – Allan M. Cormack,
Godfrey N. Hounsfield

1986 – Heinrich Rohrer, Gerd Binnig

2003 – Paul C. Lauterbur,
Sir Peter Mansfield

Computer assisted measurement – for your science experiments



With computer-assisted experiments from PHYWE you rely on a system that perfectly matches the demands of modern scientific education. Approximately 50% of the total number of TESS expert university experiments are computer-based. PHYWE offers the unique Cobra4 system with completely new experimentation possibilities. Be inspired by more than 200 described experiments with Cobra4.

The corresponding software measure stands for simple and reliable data recording, analysis and further processing – and it is available in 24 languages. Get more information about our Cobra4 program in the brochure "Experiments with Cobra4"

Benefits

- wireless measurements – comfortable and modern
- more than 30 sensors for more than 50 measurands
- time-saving: settings can be saved
- fully automatic sensor identification
- up to 99 sensors can be addressed simultaneously
- can be used as a hand-held measuring instrument



Cobra4 Interface System

The Cobra4 interfaces



Wireless measurement with Wireless-Link + Wireless Manager + Remote-Link



For high data rates with the USB-Link



Mobile-Link - even more functions included as of 2013 - no computer necessary

The Cobra4 sensor family

Cobra4 | PHYWE

One of over 30 available sensors

Fast and secure connection of sensors

SD card for data storage

GPS

2,4" Display 65.536 colors

Intuitive operation

USB for charge and data transfer

NEW

Our roadmap for future products – Coming up 2013



Cobra4 Sensors



Sound level
(12669-00)

Skin resistance
(12677-00)

Oxygen
(12676-00)

Forceplate
(12661-00)

Colorimeter
(12634-00)

Cobra4 Signal-Link –

The integrated and high accuracy interface for high speed experiments



Features

- Integrated unit of voltage & current sensors + USB interface
- 4 channels (2x current, 2x voltage), electrically isolated
- True RMS converter for all channels
- High resolution: up to 5 microvolts, up to 1 microampere
- Sampling rate: > 1 MHz for current channels and >5 MHz for voltage channels
- Compatible to all Cobra4 equipment

Digital function generator – universal and intuitive

Cobra4

compatible

NEW

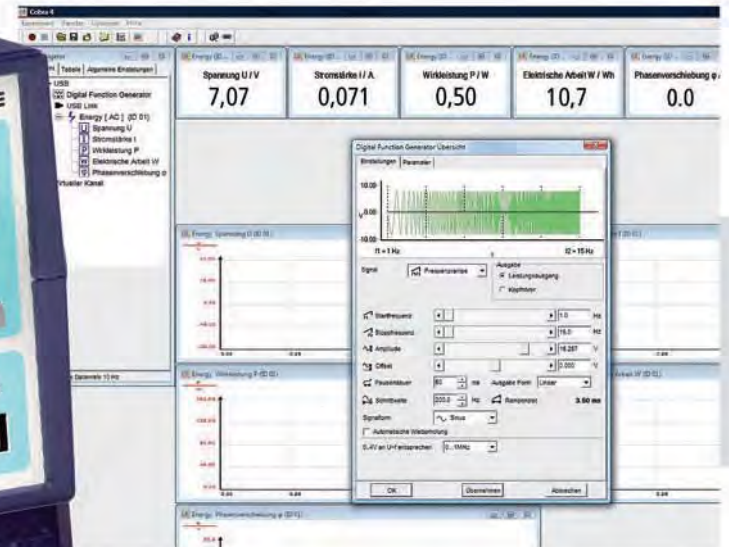

Features

- Universal, programmable voltage source with a bandwidth of 1 MHz and an output current of 1 A
- Can be used with Cobra4 or as a stand-alone device
- Intuitive operation via function keys and a rotary control knob
- Illuminated display for optimum visibility
- Low distortion factor and high signal-to-noise ratio for brilliant signals (acoustics/hearing)
- $U = U(f)$ output for a particularly easy pick-up of the frequency – ideal for analysing circuits with frequency ramps
- Part of more than 25 TESS experiments



Faraday effect (P2260106)



Chladni's figures (P2150702)

Lucas-Nülle – Committed to future generations



Lucas-Nülle GmbH is among the world's leading developers, manufacturers and vendors of training systems in different technical areas. Founded in 1973 by Rolf Lucas-Nülle the company has risen to become a 'global player' and is part of the Lucas-Nülle Group. Besides Lucas-Nülle itself, the group consists of two other companies: Phywe Systeme GmbH & Co. KG and INTEA GmbH.

Together the group employs some 300 staff and has an annual turnover of approximately 80 million euro. In the international market of training and education, the three companies hold a leading position.



Lucas-Nülle has been producing training equipment at its company headquarters in Kerpen near Cologne for several years. Its products are shipped from there to customers in more than 100 countries.



Lucas-Nülle training systems are deployed throughout the world where they are seen as the benchmark for quality, efficiency and technology. These systems cover areas such as:

- | | |
|---|---|
|  Electrical Wiring |  Electropneumatics and Hydraulics |
|  Electrical Power Supply Technology |  Measurement and Instrumentation Technology |
|  Renewable Energies |  Refrigeration and Air-conditioning Technology |
|  Power Electronics, Electrical Machines, Drive Technology |  Microcomputers |
|  Fundamentals of Electrical Engineering and Electronics |  Automation |
|  Communications Technology |  Automotive Technology |
|  Control Technology |  Laboratory Systems |

Thanks to know-how gained over many years, Lucas-Nülle can offer more than just equipment. The company now provides comprehensive training concepts and solutions as well. Every training system is equipped with extensive PC-based software. In addition, there is also easy-to-use, time-saving administration software for managing students and classes, with which teaching staff are presented with the opportunity to create their own questions, experiments and measuring exercises in order to test students' knowledge.

One other key aspect in achieving optimum success for training is the link with authentic practice. Experiments carried out on Lucas-Nülle's training systems therefore combine theory and practice, generate skills out of knowledge and thus ensure competence in the handling of equipment. With such a concept, based on the latest educational insights, Lucas-Nülle provides a unique solution, which enables optimum rates of learning and facilitates the step up to subsequent careers.

Contact details

Lucas-Nülle GmbH	Phone +49 2273 567-0
Siemensstraße 2	Fax +49 2273 567-30
50170 Kerpen (Germany)	www.lucas-nuelle.com

General notes on safety

Notes on safety

The regulations for dealing with electrical devices, lasers, radioactive materials and hazardous materials are not uniform worldwide. Before any experimentation, it is essential that you become familiar with the national and local laws, directives and ordinances regarding the handling of the-

se appliances and materials, as well as their storage and transport.

You can refer as an example to our notes on safety, which correspond to the high German and EU standards. The laws in the respective country are binding, however.

1.) Experiments using electrical energy

The utilisation of the electrically operated devices (mains power supply) that are offered herein is only allowed in science rooms of educational institutions, schools, universities, and laboratories, but NOT in residential areas.

Experiments at school usually use non-hazardous extra-low voltages ($< 25\text{ V}\sim$ / $< 60\text{ V}\sim$). The following safety notes provide information about the existing legal regulations. In addition, they include rules of conduct for the responsible teacher for the execution of experiments with hazardous voltage levels.

When performing experiments with electrical energy, it must be absolutely sure that the persons involved in the experiment cannot come into contact with hazardous voltage. The professional (teacher) who supervises/conducts the experiment is responsible for this.

In the "Safety requirements for electrical equipment for measurement, control, and laboratory use" (DIN EN 61010-1, VDE 0411 part 1) of the European Union, non-hazardous voltage is defined as voltage $< 33\text{ V}\sim$ or $< 70\text{ V}\sim$ or, in the case of higher voltage, with a limited current of $0.5\text{ mA}\sim$ and $2\text{ mA}\sim$ maximum.

Other restrictions for schools providing general education have been decreed by the standing conference of the minister of education and cultural affairs of Federal Republic of Germany in the "Directives concerning safety during lessons" (GUV-SI 8070) with reference to the standard VDE 0105 part 12 ("Operation of power installations - Particular requirements for experiments with electrical energy in lecture rooms"). In these directives, the voltage limits for students up to the German class level 10 (age approximately 16 years) have been fixed at $25\text{ V}\sim$ and $60\text{ V}\sim$ maximum.

Professionals (usually teachers) and students of class levels higher than level 10 may work with hazardous voltages in exceptional cases, if the teaching objective cannot be reached with non-hazardous voltage. In this case, the teacher must be present during the experiment.

The following rules and regulations should be observed:

1. Electrical safety

(DIN EN 61010-1, VDE 0105 part 12, GUV-SI-8070)

Prior to the first experiments of students, trainees, or apprentices with electrical energy in a laboratory or classroom, the students, trainees, and apprentices must be informed in detail about the hazards of the electrical current and about the applicable safety instructions.

Prior to using the electrical devices, they must be checked for signs of damage! Do not use the device if it is damaged!

The operating instructions of the equipment that is used for the experiment must be followed!

Do not use hazardous voltages ($> 25\text{ V}\sim$ and $> 60\text{ V}\sim$) in student experiments!

The professional must re-check the experiment set-up (circuit) prior to the start of the experiment and inform the user of any potential hazards!

Modifications of the experiment set-up (set-up, conversion, and take-down) must only be performed when the set-up is completely disconnected from the power supply and when all poles of the supply voltage are switched off!

If measurements or adjustments are unavoidable during an experiment with hazardous voltage, work only with one hand and hold the other behind the back or put it in a pocket!

Ensure that there is a sufficient number of emergency OFF switches in the laboratory.

Use only 4-mm safety cables that are protected against accidental contact (e.g. PHYWE ref. no. 07336-01) when performing experiments with hazardous voltages!

After the completion of the experiment, it should be taken into consideration that component parts, such as capacitors, may supply hazardous voltage even some time after the equipment has been switched off!

Experiments with set-up transformers require special safety measures. Even if the primary side of the transformer is supplied with extra-low voltage (< 25 V~), very high hazardous voltages may be generated on the secondary side by the transformation, e.g. if the coils get mixed up!

If demonstration experiments are performed with hazardous voltages, the teacher or lecturer must ensure a sufficient safety distance from the students. In addition, these kinds of experiments must be marked with the danger sign "High voltage!" (PHYWE ref. no. 06543-00)!

Experiments that are directly supplied with mains power must not be performed unless a residual current circuit breaker (< 30 mA), e.g. a safety plug/socket assembly (PHYWE ref. no. 17051-93) or a variable isolating transformer (PHYWE ref. no. 13535-93), has been installed before the set-up. Do not plug the 4-mm connecting cables directly into the earthing contact socket outlet (SCHUKO socket)!

If power supply units (e.g. power supply unit for students, PHYWE ref. no. 13505-93) are used that do not produce hazardous voltages (extra-low voltages < 25 V~ and < 60 V-), simple, unprotected 4-mm connecting cables and other non-insulated components may also be used for student experiments.

**2. EMC (electromagnetic compatibility)
(Technical recommendation concerning the application of the EMC Act on electrical teaching equipment, Reg TP 322 TE01)**

Experiment set-ups for the demonstration of physical processes must only be used in science rooms at schools, universities, and other educational institutions!

The teacher (expert) who sets up and performs the experiments is responsible for the compliance with the requirements for the EMC Act on the electromagnetic compatibility of equipment! The experiment set-ups do not require a CE mark or declaration of conformity, but the teacher as an expert must take all the necessary measures in order to avoid interferences in the environment!

Possible EMC measures:

- Ensure shielding and equipotential bonding!
- Keep a sufficiently large distance from sensitive equipment!
- Use short connecting cables (in order to reduce RF emission)!
- Floor coverings that may lead to static charges should be avoided and the body should be discharged prior to touching any sensitive experiment equipment!
- RF emitters, e.g. mobile phones, should not be used in close vicinity of the experiment set-up!
- Critical experiment set-up and devices (e.g. Van de Graaf generator, Ruhkoeff induction coil, transmitter), which can cause interferences even at a distance of several 100 metres should be switched on as briefly as possible.

2.) Experiments using lasers

In general, the "Directives concerning safety during lessons" (GUV-SI 8070) are applied at schools. In accordance with these directives, the following points must be observed when working with lasers:

1. Only lasers of class 1, 1 M, 2, and 2 M1 in accordance with DIN EN 60 825 may be used at schools.
2. Lasers of class 1 M, 2, and 2 M must be kept under lock and key.
3. Prior to setting up and performing experiments with lasers of class 1 M, 2, and 2 M, the students who observe or are involved in the experiment must be informed as to the risk to the eyes that is caused by the laser light.

These lasers must only be used under the supervision of the teacher.

4. The area in which experiments with lasers of class 1 M, 2, and 2 M are performed must be marked with laser warning signs during the operation of the laser. This laser area of experiment set-ups must be secured against accidental access by some form of delimitation.
5. The set-up and performance of experiments with lasers of class 1 M, 2, and 2 M must ensure that looking into the direct laser beam or into the reflected beam is avoided, e.g. with the aid of some kind of screening. If lasers of class 1 M and 2 M are used, the beam cross-section must not be reduced, i.e. these lasers must not be used

in combination with converging components (e.g. magnifying glasses).

6. The use of laser devices of class 3 B or 4 in other educational institutions (universities etc.) must be reported to the responsible accident insurer and to the responsible occupational safety and health authority prior to the first start-up of the lasers.

For the use of laser systems of class 3 B or 4, a competent person must be appointed the laser safety officer in writing.

Additional information concerning the use of lasers can be found in the documents of the German Social Accident Insurance "GUV-V B – Laser radiation" and "GUV-I 832 – Use of laser systems". These documents are mainly based on the EU standard "DIN EN 60825-1 – Safety of laser products".

3.) Handling of radioactive products

In Germany, the handling of radioactive substances is controlled by the German Radiation Protection Ordinance (Strahlenschutzverordnung, StrlSchV). The legal bases of this ordinance are articles 25 to 27 combined with appendix V of the ordinance dated 20 July 2001, last amended by article 2 of the law of 02/08/2008. Substances within the exemption limits (see Appendix V of the German Radiation Protection Ordinance (StrlSchV) for the exemption limits) can be supplied to schools without any conditions. If the exemption limits are exceeded, the school will need a special handling permit issued by the responsible supervisory authority prior to purchasing the substances.

If several substances within the exemption limits are owned and/or purchased, the sum formula that is stated in the German Radiation Protection Ordinance must be observed.

Radioactive substances must be protected against unauthorised persons, which is why they must be stored in a theft-proof manner. In addition, the handling regulations of the German Radiation Protection Ordinance must be observed. Substances that have become unusable must be handed over directly to the responsible collection centre or to a disposal company.

4.) Safety instruction for handling hazardous materials

Before any experimentation with hazardous materials, it is essential that you become familiar with the national and local directives and ordinances concerning the handling of hazardous materials, their storage and transport. The basic principle is that all hazardous materials must be dealt with cautiously and carefully. It is of course required that, in case of experiments, neither the students nor the teachers be exposed to any unnecessary dangers to health. The instructions

of the safety data sheets for the individual materials, in the most current version in each case, are to be considered, as well as the accident-prevention specifications and the respective workplace-related operating instructions. The waste disposal of used hazardous materials must be implemented according to recognized methods. The local specifications for the proper removal of chemical residues are to be considered in this case.

General Terms and Conditions (GTC)

of PHYWE Systeme GmbH & Co. KG

§ 1 Application of Conditions

1. These General Terms and Conditions (hereinafter referred to as GTC) shall apply for all goods, services and offers of PHYWE Systeme GmbH & Co. KG (hereinafter referred to as PHYWE) for its customers (hereinafter referred to as Customer). They shall apply equally for all future business between the contract parties without requiring a repeated reference. General Terms and Conditions of the Customer shall apply only if expressly approved by PHYWE in writing.
2. All deviating agreements between PHYWE and the Customer shall be set down in writing; a waiver of the written form does not have any effect on the agreement's validity. In the event of such an agreement these GTC shall be of lesser importance and shall supplement the agreement.
3. PHYWE reserves all rights to PHYWE operational and offer documents. If no order is placed, all documents shall be returned immediately of the Customer's own accord. All information in them and from other transactions shall be treated as strictly confidential.
4. All offers, samples and test products as well as their technical data and descriptions in the respective product information and promotional materials on the PHYWE website are for information only and are not binding. They do not represent a warranty of quality or application.
5. Insofar as PHYWE considers it necessary for the completion of its performances, PHYWE is authorized to exchange job-related data with assistants or trading partners. If the Customer does not desire such an information exchange, the Customer may object to it in writing at any time.

§ 2 Offer and Contract Conclusion

PHYWE's offers are not binding. PHYWE reserves an acceptance period of two weeks from receipt at PHYWE regarding the Customer's binding orders. Verbal statements of acceptance (by phone) and all Customer orders shall be confirmed by PHYWE in writing or by telex; a waiver of the confirmation does not affect the effectiveness of verbal statements of acceptance and orders (by telephone).

§ 3 Prices

1. The prices given in the PHYWE price list or the PHYWE order confirmation, exclusive of the relevant applicable value-added tax in the respective country, shall be binding. Additional goods and services are charged separately.
2. The prices are "ex work PHYWE" and include PHYWE standard packaging. Special packaging or other requests from the Customer, such as packaging in certain lots, are charged separately. Deviating provisions may be agreed between PHYWE and the Customer or by PHYWE for a region or a country in writing from time to time.

§ 4 Delivery and Performance Terms

1. Delivery dates or terms that may be agreed upon, both binding and unbinding, shall be set down in writing. Non-binding delivery terms may be exceeded by up to 8 weeks by PHYWE; only after expiration of this term we shall fall into arrears by reminder of the Customer. Delivery terms shall start as of contract conclusion and acceptance of payment details by PHYWE. In the event that changes to the contract are agreed upon, it is subsequently required to agree on a new delivery date at the same time. Claims for damages or recourse of the Customer towards PHYWE shall be excluded in any case.
2. In the event of delivery and performance delays due to force majeure, natural disasters as well as due to labour disputes, traffic or operation disturbances, lack of material through no fault of their own and similar reasons on PHYWE and its suppliers' part, the Customer is not entitled to withdraw from the contract or to assert claims towards PHYWE. The Customer is entitled to withdraw from the contract if the aforementioned reasons cause an extension of the delivery date by more than four months. PHYWE is entitled equally to withdraw from the contract. Claims for damages or recourse of the Customer towards PHYWE shall be excluded in any case.

3. PHYWE is entitled to make partial deliveries and partial performances at any time unless the deliveries and performances are to be made fully and completely in accordance with the contractual arrangements.
4. PHYWE's compliance with delivery and performance obligations requires the Customer's timely and proper compliance with its obligations.
5. If the Customer falls into arrears, PHYWE is entitled to demand reimbursement of the additional expenses it had to make for the unsuccessful offer and storage and maintenance of the owed object; with commencement of default of acceptance the risk of incidental deterioration and accidental loss is transferred to the Customer.

§ 5 Export Business

PHYWE is entitled to withdraw from the contract regarding delivery of such products (partial withdrawal) that require approval of the federal ministry for economics and export control, the Federal Institute for Medicaments and Medical Products or a similar governmental institution for their export from Germany or their import in their country of destination pursuant to legal provisions in the event that the approval is not issued or probably may not be obtained until the agreed delivery date. PHYWE shall immediately advise the Customer of this and possibly reimburse a compensation for the part of the performance affected by the withdrawal.

§ 6 Shipping and Transfer of Risk

1. Place of performance is Göttingen. The delivery condition is "ex works PHYWE". Other agreements must be made in writing.
2. The Customer may request PHYWE to ship the goods. It shall bear the costs and risk for it. In the case of a forwarding order the risk is transferred to the Customer as soon as the shipment had been handed over to the person executing the transport. If PHYWE is able to ship the goods at the time determined by contract and the shipment is delayed at the Customer's request the risk is transferred to the Customer at notice of readiness for shipment.
3. At the Customer's request shipments shall be insured in its name and on its account.

§ 7 Claims for Defects/Guarantee

1. PHYWE is working pursuant to the guarantee claims typical in Germany and the EU. If a PHYWE product shows any other defect already present at delivery, the Purchaser shall advise it immediately and provide evidence. In such an event PHYWE shall repair the defect or deliver a product free of defects (supplementary performance) pursuant to legal provisions. PHYWE shall bear the expenses required for the purposes of supplementary performance, including but not limited to transport, labour and material cost. Additional expenses caused by the sold product being brought to a place other as the domicile or the branch office of the Customer shall not be borne by PHYWE.
2. Insignificant or commercial deviations of the delivered goods in size, shape and colour being in the material's nature do not establish claims for defects by the Customer. Article 377 German Commercial Code applies.
3. PHYWE reserves the right to changes to the PHYWE products required for technical or other reasons not affecting usability and not reducing the service's value and for technical improvements. They do not establish claims for defects, abatement or withdrawal from the transaction by the Customer.
4. If PHYWE's operation or maintenance instructions are not adhered to, changes to the products are made, parts are exchanged or consumables not complying with the original specifications are used, the Customer may not assert claims for defects if the Customer does not refute a substantiated claim to the effect that it was only one of those circumstances that had caused the defect.
5. The Customer must immediately inform customer service management/PHYWE's technical hotline of visible defects in writing, however, the latest within one week after receiving and/or accepting the

delivered goods. Defects that can not be discovered within this period even with careful examination shall be communicated and proven to PHYWE in writing immediately upon discovery.

6. Claims for defects for regular wear and tear are excluded.
7. Only the immediate Customer is entitled to claims for defects towards PHYWE and may not transfer them to third parties.
8. Claims for defects fall under the statute of limitations after 12 months as of delivery of the goods under contracts with the Customer. Retaining payments by the Customer is only admissible if the proportion of the occurred defect is appropriate.

§ 8 Repairs

If the Customer is not entitled to claims for defects pursuant to § 7 or if the statutory period of limitation pursuant to § 7.8 is expired and PHYWE and the Customer agree on a repair of the products § 7.8 applies equally to the limitation of a defect of the repair.

§ 9 Reservation of Title

1. PHYWE reserves title to the goods until fulfilment of all claims from the business relation for whatever legal reason including the claims arising in the future or conditional claims. If the realisable value of existing securities (goods subject to reservation of title pursuant no. 3 below and transferred accounts receivable pursuant no. 5 below) exceeds the secured claims by more than 10 % in total PHYWE is obliged insofar to release securities at the seller's discretion at the Customer's request.
2. Joint ownership rights arising from combination or mixing are deemed goods subject to reservation of title. PHYWE has an appropriate right to the reservation of title on these goods as well.
3. The Customer is entitled to process and sell the goods subject to reservation of title in the course of normal business unless it falls into arrears. Pledging or protective conveyance is inadmissible. By way of security the customer shall immediately transfer to PHYWE all claims (including any outstanding balance claims from the current accounts) arising from the resale or another legal reason (insurance, inadmissible action) in connection with the goods subject to reservation of title to their full extent. PHYWE shall give it the revocable authorization to collect the claims transferred to PHYWE for its account in its own name. This authorization for collection may only be withdrawn if the Customer does not properly fulfil its payment obligations.
4. In the event that the Customer behaves contrary to the contract – including but not limited to falling into arrears – PHYWE is entitled to take back the goods subject to reservation of title after expiration of an appropriate additional respite or demand the transfer of the Customer's claims for return towards third parties as the case may be. PHYWE taking back the goods subject to reservation of title does not constitute a withdrawal from the contract unless PHYWE has expressly stated such withdrawal.

§ 10 Payment

1. All payments exceeding the credit limit of the Customer with PHYWE confirmed by PHYWE in writing shall be made for payment in advance or confirmed with an irrevocable letter of credit from a large European bank accepted by PHYWE or an equivalent bank guarantee.
2. Within or above credit limit invoices shall be payable without deducting a cash discount or other discounts with PHYWE receiving the payment within 20 days as of contract conclusion and receipt of the invoice or an equivalent payment listing by the Customer.
3. In the event of orders with a purchase price surpassing € 25,000.00 the Customer shall make an advance payment of 40% of the purchase price for PHYWE products and 60% of the purchase price for third party products. The advance payment is due on contract conclusion and receipt of an invoice or equivalent payment listing.
4. A payment is only deemed made when PHYWE has the amount at its disposal. In case of cheques the payment is only deemed made when the cheque has been cashed.

5. The Customer shall fall into arrears 3 days after maturity of the claim by PHYWE and receipt of an invoice or delivery without it requiring a written reminder. If the Customer falls into arrears PHYWE is entitled to demand interest of 8% above the relevant basic interest rate of the European Central Bank at the respective point in time. PHYWE may submit evidence of a greater damage
6. If PHYWE becomes aware of circumstances calling the Customer's financial standing into question, including but not limited to not cashing its cheque or stopping its payments, or if PHYWE becomes aware of other circumstances calling the Customer's financial standing in question, PHYWE is entitled to call the complete outstanding debts even if it had accepted cheques.
7. The Customer is only entitled to set off its debts if the counterclaims have been established as final and absolute or are undisputed. The same shall apply for the right of retention pursuant to article 273 German Civil Code, the commercial right of retention pursuant to article 369 German Civil Code and the right of refusal of services pursuant to article 320 German Civil Code.

§ 11 Copyright Infringements

1. PHYWE shall exempt the Customer and its customers from claims arising from infringements of copyrights, trade marks or patents unless the design of a delivery object had been made by the Customer. PHYWE's exemption obligations shall be limited to the amount of the predictable damage. An additional requirement for exemption is that in case of a legal dispute (article 72 German Code of Civil Procedure) the Customer informs PHYWE of the dispute and that the alleged legal infringement may be ascribed to the construction of PHYWE's delivery items without combination or use with other products.
2. Optionally PHYWE has the right to free itself from the obligations assumed in clause 1 by either
 - a) obtaining the required licences regarding the alleged infringed patents, or
 - b) providing the Customer with a changed delivery item or part of it that rectifies the infringement reproach concerning the delivery item by exchanging it for the infringing delivery items or their parts unless the changed delivery item (or parts of it) falls behind the original performance regarding the usability and/or its value.

§ 12 Liability

1. PHYWE shall be liable for breaches of contractual and non-contractual obligations, including but not limited to impossibility, delay and unlawful acts, only in cases of malicious intent and gross negligence – of its executive employees as well – limited to damages foreseeable at contract conclusion.
2. Claims for damages of material defects shall fall under the statute of limitation after 12 months as of delivery of the goods – with exception of personal injury or wilful or grossly negligent breaches of duty. The limitation of legal regress claims remains unaffected. The relevant legal provisions apply for claims for damages on account of other legal reasons.

§ 13 Applicable law, jurisdiction, partial invalidity

1. In addition to these provisions German law with exemption of the provisions of the UN Convention on Contracts for the International Sale of Goods dated 11/04/1980 (CISG) applies.
2. Place of jurisdiction is Göttingen
3. If a provision in these General Terms and Conditions or a provision under other agreements is or becomes ineffective the validity of all other provisions or agreements shall remain unaffected.

General Terms and Conditions of PHYWE Systeme GmbH & Co. KG, last updated on 01/08/2010

After announcement of new General Terms and Conditions all previous General Terms and Conditions lose their validity.



Indices

10.1	Numerical index	234
10.2	Alphabetical index	236

10 Indices

10.1 Numerical index

Art no.	Description	Page	Art no.	Description	Page
P1043960	Specific heat capacity of water (with Cobra4)	145	P2360401	Stirling engine with an oscilloscope	158
P1221300	Ferromagnetism, paramagnetism and...	47	P2360460	Stirling engine (with Cobra4)	158
P1253500	Torque	16	P2410101	4 Point Method / Measurement of low...	133
P1521063	The pH value of various soils (with Cobra4)	202	P2410160	Ohm's law (with Cobra4)	131
P1521163	Salinity of soils and plant substrates...	201	P2410200	Wheatstone bridge	134
P2120100	Moments	16	P2410401	Temperature dependence of different...	53, 112
P2120200	Modulus of elasticity	14	P2410460	Temperature dependence of different...	53, 112
P2120300	Mechanical hysteresis	15	P2410500	Kirchhoff's laws	132
P2130101	Hooke's law	19	P2410560	Kirchhoff's laws (with Cobra4)	132
P2130160	Hooke's law (with Cobra4)	19	P2410700	Semiconductor thermogenerator - Seebeck...	130, 157
P2131301	Moment of inertia and angular...	21	P2410800	Peltier heat pump	156
P2131305	Moment of inertia and angular...	21	P2410901	Characteristic curves of a solar cell	161
P2131311	Moment of inertia and angular...	21	P2410960	Characteristic curves of semiconductors...	111, 151
P2131315	Moment of inertia and angular...	21	P2411100	Characteristic curve and efficiency of a...	164
P2131360	Moment of inertia and angular...	21	P2411200	Faraday's law	162
P2131500	Moment and angular momentum	20	P2411360	Second order conductors. Electrolysis...	129
P2131900	Laws of gyroscopes / 3-axis gyroscope	25	P2420100	Electric fields and potentials in the...	113, 153
P2132000	Laws of gyroscopes / cardanic gyroscope	26	P2420201	Charging curve of a capacitor / charging...	114, 152
P2132660	Harmonic oscillations of spiral springs - ...	23	P2420600	Dielectric constant of different materials	57, 113
P2132701	Forced oscillations - Pohl's pendulum	24	P2420715	Switch-on behaviour of a capacitor and an...	115, 152
P2132760	Forced oscillations - Pohl's...	24	P2420760	Switch-on behaviour of a capacitor and an...	115
P2132801	Moment of inertia / Steiner's theorem	22	P2430201	Magnetic field of single coils/...	118
P2133000	Torsional vibrations and torsion modulus	17, 45	P2430260	Magnetic field of single coils/...	118
P2133100	Moments of inertia and torsional vibrations	22	P2430760	Ferromagnetic hysteresis (with Cobra4)	47
P2140100	Density of liquids	28	P2430800	Magnetostriction with the Michelson...	48, 181
P2140200	Surface of rotating liquids	29	P2440100	Transformer	123, 152
P2140300	Viscosity of Newtonian and non-Newtonian...	30	P2440201	Magnetic induction	120
P2140400	Viscosity measurement with the falling...	31	P2440260	Magnetic Induction (with Cobra4)	120
P2140500	Surface tension with the ring method (Du...	32	P2440301	Inductance of solenoids	121
P2140700	Barometric height formula	33, 200	P2440360	Inductance of solenoids (with Cobra4)	121
P2150305	Velocity of sound in air with Universal...	39	P2440401	Coil in the AC circuit	117
P2150405	Acoustic Doppler effect with universal...	41	P2440460	Coil in the AC circuit (with Cobra4)	117
P2150501	Chladni figures	104	P2440501	Capacitor in the AC circuit	116
P2150601	Velocity of sound using Kundt's tube	40	P2440560	Capacitor in the AC circuit (with Cobra4)	116
P2150605	Velocity of sound using Kundt's tube...	40	P2440601	RLC circuit	135
P2151000	Optical determination of the velocity of...	37	P2440660	RLC circuit (with Cobra4)	135
P2151100	Phase and group velocity of ultrasound in...	38	P2440700	Rectifier circuits	136
P2151200	Temperature dependence of the velocity of...	38	P2440801	RC filters	137
P2152415	Ultrasonic Doppler effect (with Cobra3)	42	P2440905	High-pass and low-pass filters with...	138
P2152460	Ultrasonic Doppler effect (with Cobra4)	42	P2440915	High-pass and low-pass filters with the...	138
P2220200	Newton's rings with interference filters	172	P2440960	High-pass and low-pass filters (with Cobra4)	138
P2220205	Newton's rings with optical base plate	172	P2441005	RLC measuring bridge	134
P2220500	Michelson interferometer with optical...	178	P2441101	Resistance, phase shift and power in AC...	122
P2220505	Michelson interferometer with optical...	178	P2441211	Induction impulse (with Cobra3)	119
P2220700	Refraction index of air and CO2 with the...	179	P2441260	Induction impulse (with Cobra4)	119
P2220705	Refraction index of CO2 with the...	179	P2450201	Coupled resonant circuits	139
P2220800	Quantum eraser	184	P2450301	Forced oscillations of a nonlinear...	140
P2220900	Michelson interferometer - High...	105, 180	P2450360	Forced oscillations of a nonlinear...	140
P2221000	Doppler effect with the Michelson...	182	P2530101	Hall effect in p-germanium	55, 125
P2221100	Refraction index of air with the...	183	P2530111	Hall effect in p-germanium (with Cobra3)	151
P2221205	Fabry-Perot interferometer - ...	185	P2530160	Hall effect in p-germanium (with Cobra4)	55, 125
P2221206	Fabry-Perot interferometer - optical...	186	P2530201	Hall effect in n-germanium	55, 125
P2221305	Twyman-Green interferometer	180	P2530260	Hall effect in n-germanium (with Cobra4)	55, 125
P2230100	Diffraction at a slit and...	169	P2530300	Hall effect in metals	54, 124
P2230105	Diffraction at a slit and...	169	P2530401	Band gap of germanium	126
P2230400	Diffraction intensity due to multiple...	170	P2530411	Band gap of germanium (with Cobra3)	126
P2230405	Diffraction of light through a double...	170	P2530460	Band gap of germanium (with Cobra4)	126
P2230600	Diffraction intensity at a slit and at a...	171	P2532000	Atomic Resolution of the graphite...	68
P2230605	Diffraction intensity at a slit and at a...	171	P2532500	Investigate in surface atomic structures...	68, 103
P2240400	Lambert's law	166	P2534000	Self-assembled molecular networks of...	69
P2240405	Lambert's law of radiation on...	166	P2534500	Self-assembled molecular networks of TMA...	69
P2250100	Polarisation through quarter-wave plates...	167	P2535000	Quantum Mechanics by STM - Tunneling...	68
P2250105	Polarisation through quarter-wave plates...	167	P2536000	Imaging and characterization of...	68
P2250200	Polarimetry	173	P2537000	Roughness and nanomorphology of different...	70, 103
P2250300	Fresnel's equations - theory of...	168	P2538000	Basic methods in imaging of micro and...	72, 102
P2250305	Fresnel's law - theory of reflection...	168	P2538100	Basic methods in force spectroscopy to...	74, 102
P2250505	Polarimetry with optical base plate	173	P2538200	Using the phase contrast mode to...	75, 102
P2260100	Faraday effect with optical profile bench	174	P2538400	Imaging of biological and medical micro...	73
P2260106	Faraday effect with optical base plate	56, 174	P2538500	Investigate in magnetic micro and...	49, 76
P2260300	Recording and reconstruction of holograms...	187	P2540010	Counter tube characteristics	83
P2260305	Transfer hologram - master hologram	106, 188	P2541301	Examination of the structure of NaCl...	61, 207
P2260306	Holography - Real time procedure	188	P2541401	X-ray investigation of cubic crystal...	62, 208
P2260511	LDA - laser Doppler anemometry with...	34, 177	P2541501	X-ray investigation of hexagonal crystal...	62, 208
P2260560	LDA - Laser Doppler Anemometry (with Cobra4)	34, 177	P2541601	X-ray investigation of crystal structures...	63, 209
P2260701	Helium neon laser, basic experiment	189	P2541602	X-ray investigation of crystal structures...	63, 209
P2260705	Helium neon laser, advanced experiment	189	P2542001	Determination of length and position of...	82
P2260800	Optical pumping	190	P2542701	Debye-Scherrer diffraction measurements...	83
P2260900	Nd:YAG laser	191	P2544501	Qualitative X-ray fluorescence...	66, 213
P2261000	Fibre optics	192	P2544601	Qualitative X-ray fluorescence analysis...	66, 214
P2261100	Fourier optics - 2f arrangement	175	P2544701	Qualitative X-ray fluorescence analysis...	64, 210
P2261200	Fourier optics - 4f arrangement - ...	176	P2544901	Qualitative X-ray fluorescence analysis...	212
P2310100	Thermal expansion in solids and liquids	50	P2545001	Quantitative X-ray fluorescence analysis...	65, 84
P2310200	Thermal expansion in solids	50	P2545101	Quantitative X-ray fluorescence analysis...	66, 84
P2310300	Thermal expansion in liquids	50	P2545201	X-ray fluorescence spectroscopy / layer...	85
P2320201	Heat capacity of gases	145	P2550100	Computed tomography	86
P2320260	Heat capacity of gases (with Cobra4)	145	P2550300	Principles of beam intensity	89
P2330101	Heat capacity of metals	51, 146	P3010701	Thermal conductivity of gases	144
P2330160	Heat capacity of metals (with Cobra4)	51, 145	P3011160	Gay-Lussac's law (with Cobra4)	148
P2330200	Mechanical equivalent of heat	147	P3011260	Amontons' law (with Cobra4)	148
P2330260	Mechanical equivalent of heat (with Cobra4)	147	P3011360	Boyle's law (with Cobra4)	148
P2350101	Stefan-Boltzmann's law of radiation...	159	P3021401	Determination of the enthalpy of...	150
P2350160	Stefan-Boltzmann's law of radiation...	159	P3021501	Determination of the heat of formation of...	163
P2350200	Thermal and electrical conductivity of metals	52, 143	P3021701	Determination of the heating value of...	149
P2360100	Solar ray collector	160	P3060962	Nernst equation (with Cobra4)	127, 153
P2360200	Electric compression heat pump	155	P3061262	Temperature dependence of the...	128
P2360360	Heat insulation / heat conduction	154	P4100160	Comparison of the heat capacities of...	194

Art no.	Description	Page	Art no.	Description	Page
P4100560	Conductivity of various water samples...	195	13029-02	TESS advanced Physics manual...	109
P4100760	The origin of acid rain (with Cobra4)	196	13230-77	TESS advanced Physics set Magnetism, MAG	110
P5140100	Mechanics of flow	35	13411-88	TESS advanced Equipotential lines...	109
P5141100	Level measurement	36	13412-88	TESS advanced Electric Motor / Generator...	109
P5142100	Flow Measurement Ultrasonic Doppler effect	35	13422-88	TESS advanced Chemistry Electrochemical...	110
P5160100	Velocity of ultrasound in solid state...	90	13470-88	TESS advanced Electronics necessary...	108
P5160200	Ultrasonic echography (A-Scan)	91	13500-93	Power supply, universal	162
P5160300	Ultrasonic echography (B-Scan)	92	13505-93	Power supply 0...12 V DC/6 V, 12 V AC, 230 V	114
P5160400	Angle beam measurement	93	13533-93	Multitap transformer, 14 VAC/ 12 VDC, 5 A	123
P5160500	Time of flight diffraction (TOFD)	94	13601-99	Universal Counter	39
P5160600	Detection of discontinuities	95	13617-93	Temperature meter digital, 4-2	52
P5160700	Frequency dependence of resolution power	96	13625-93	LF amplifier, 220 V	40
P5160800	Attenuation of ultrasound in solid state...	97	13626-93	Universal measuring amplifier	54, 133
P5160900	Shear waves in solid state materials	18, 44	13654-99	Digital Function Generator, USB, incl....	56, 104
P5161000	Determination of the focus zone	99	13670-93	High voltage supply unit, 0-10 kV	57, 113
P5161100	Mechanical scan methods	100	13715-93	Work and power meter	122, 155
P5161200	Ultrasonic computed tomography	101	13727-99	Multi channel analyser	64, 210
P5510100	Metallographic sample preparation - ...	77	13900-00	Ultrasound operation unit	42
P5510200	Metallographic sample preparation - ...	78	13920-99	Ultrasonic generator	37
01006-02	TESS Physics manual Electric/Electronic...	108	13921-01	Extension set: Non destructive testing	93
01054-00	Software interTESS Physics, Electrics /...	108	13921-02	Ultrasonic probe 4 MHz	96
01055-00	Software interTESS Physics,...	109, 110	13921-03	Extension set: Shear waves	44, 97
01157-02	Demo advanced Applied Sciences manual...	142	13921-05	Ultrasonic probe 2 MHz	94
01162-02	TESS advanced Physics manual Magnetism	110	13921-99	Basic Set Ultrasonic echoscope	18, 36
01194-02	TESS advanced manual Electrochemical...	110	13922-99	Extension Set: CT Scanner	101
01200-02	Handbook Physics X-Ray Experiments	216	13923-99	Basic set: Ultrasonic Doppler technique	35
02270-00	Moments disk	16	14414-61	XR 4.0 Software measure X-ray	83
02415-01	Rotation axle	22	14421-61	XR 4.0 Software measure CT	88
02416-00	Torsion dynamometer, 0.01 N	32	14440-62	Software "Measure Dynamics",...	27
02417-02	Turntable with angle scale	20	15221-88	TESS advanced Physics set Electric...	109
02421-00	Torsion apparatus	45	15250-88	TESS advanced Physics set Equipotential...	109
02421-88	Torsion apparatus, complete	15	15265-88	TESS advanced Physics Electricity /...	108
02536-01	Rotating liquid cell	29	15266-88	TESS advanced Physics...	108
02550-00	Gyroscope, Magnus type, incl. handbook	26	15267-88	TESS advanced Physics...	108
02555-00	Gyroscope with 3 axes	25	18220-00	Falling ball viscometer	31
02615-00	Glass jacket	163	18223-99	Rotary viscometer, 15 - 2,000,000 mPas,...	30
02615-01	Calorimeter insert for glass jacket	149	30346-00	Excursion set, soil analysis	203
03010-00	Vernier calliper stainless steel 0-160...	95	30505-77	Electrochemical measurement set	110
04233-00	Dilatometer with clock gauge	50	30834-77	Ecology case, biological water analysis	198
04366-00	Thermogenerator with 2 water baths	130, 156	30836-77	TESS Applied Sciences set examination of soil	203
04366-01	Flow-through heat exchanger	157	30837-77	TESS Biology set chemo-physical water testing	198
04371-97	Meter for Stirling engine, pVnT	158	30838-77	TESS Applied Sciences Set Gas examination	199
04401-00	Calorimeter, 500 ml	146	30839-00	Reagent case for water analysis with...	197
04403-00	Calorimetric bomb	150	36670-99	Control unit gas chromatograph	144
04507-93	High insulation house	154	43020-00	Set Gas laws with glass jacket system and...	148
06748-00	PEM electrolyser	164	45016-00	Westphal / Mohr density balance	28
06753-00	Solar ray collector	160	70000-93	Grinding and polishing machine, 230 V...	77
07163-00	Immersion probes for determining ct	53			
07182-00	Slide wire measuring bridge, simple	134			
07880-02	TESS advanced Physics manual Electric...	109			
08180-93	Laser, He-Ne, 0.2/1.0 mW, 230 V AC	166, 173			
08493-93	Immersion thermostat Alpha A, 230 V	128			
08557-00	Michelson interferometer	179			
08590-93	Basic set optical pumping	190			
08700-00	Optical base plate with rubberfeet	168, 185			
08700-01	Optical base plate in exp.case	187			
08700-55	Advanced Optics, Holography package incl...	188			
08701-00	He/Ne Laser, 5mW with holder	105, 172			
08702-93	Power supply for laser head 5 mW	48, 106			
08715-00	Interferometerplate with precision drive	180			
08724-00	Diaphragm holder for optical base plate	184			
08733-00	Faraday modulator for optical base plate	174			
08734-00	Photoelement for optical base plate	170			
08735-99	Control Unit for Si-Photodetector	34, 177			
09057-10	XR 4.0 X-ray goniometer	212			
09057-40	XR 4.0 X-ray Direct Digital Image Sensor...	88			
09057-42	XR 4.0 X-ray CT Z-rotation stage (XRstage)	88			
09058-07	XR 4.0 X-ray Implant model for X-ray...	82			
09058-30	XR 4.0 X-ray energy detector (XRED)	65, 211			
09060-00	Kinetic gas theory apparatus	33, 200			
09110-88	XRE 4.0 X-ray expert set	61, 62			
09140-88	XRS 4.0 X-ray structural analysis upgrade set	61, 62			
09150-88	XRI 4.0 X-ray imaging upgrade set	82			
09160-88	XRM 4.0 X-ray material analysis upgrade set	64, 65			
09180-88	XRCT 4.0 X-ray Computed Tomography...	63, 86			
09492-88	Demo Applied Sciences Set Renewable...	142			
09493-88	Demo Applied Sciences Set Renewable...	142			
09600-99	Compact-Scanning Tunneling Microscope (STM)	67			
09613-00	Set samples nanomorphology, for Compact...	67			
09700-99	Compact-Atomic Force Microscope (AFM)	71			
11006-01	Induction coil, 300 turns, dia. 40mm	121			
11061-00	Car, motor driven	41			
11207-30	Light barrier with counter	182			
11444-93	Difference amplifier	116, 137			
12600-00	Cobra4 Wireless Manager	112			
12601-00	Cobra4 Wireless-Link	120			
12608-88	Cobra4 wireless, extension set for...	142			
12610-00	Cobra4 USB-Link	194			
12619-77	TESS Cobra4 Environment and outdoors,...	197, 199			
12620-55	Cobra4 Mobile-Link set, incl....	202			
12623-88	Cobra4 Display-Connect, Set of...	201			
12630-00	Cobra4 Sensor-Unit Chemistry, pH and 2 x...	127			
12642-00	Cobra4 Sensor-Unit Force \pm 4 N	19, 23			
12644-00	Cobra4 Sensor-Unit Electricity, Current \pm 6...	119, 129			
12652-00	Cobra4 Sensor Tesla, magnetic field...	47, 118			
12656-00	Cobra4 Sensor-Unit Energy current,...	132			

10 Indices

10.2 Alphabetical index

A		
A-mode	93, 95	
A-scan	91, 92	
A.C. impedance	116, 117	
Absorption	160	
Absorption of X-rays	65, 66, 84, 211	
Acceptors	111, 151, 161	
Acid rain	196	
Acidification of soil and water	196	
Acidity	201	
Acidity of soils	202	
Acoustic impedance	36	
Acoustic vibrations	104	
Adhesion	32	
AFM	72, 73, 102	
Air pressure variation	39	
Algorithms	86	
Amontons' law	148	
Amount of substance	162	
Amplitude holograms	106, 187, 188	
Amplitude-distance measurements	74, 102	
Analyser	63, 64, 65, 84	
Angle beam echo	93	
Angle beam probe	93, 95	
Angular acceleration	20	
Angular frequency	24	
Angular momentum	25, 26	
Angular restoring force	22	
Angular restoring moment	22	
Angular restoring torque	17, 45	
Angular velocity	17, 20, 21, 29	
Anomalous Hall effect	54, 124	
Anthropogenic air pollution	196	
Artefacts	86, 100	
Atomic Force Microscope	72, 102	
Atomic Force Microscopy (AFM)	73, 74, 75, 102	
Atomic Force Spectroscopy	74, 102	
Atomic form factor	61, 62, 63, 207	
Atomic scattering factor	83	
Atomic structures and arrangements	68, 103	
Auger effect	65, 66, 84, 85	
Avalanche effect	53, 112, 136, 151	
Avogadro's number	162	
Axial and lateral resolution	96	
Axis of rotation	22	
B		
B-mode	100	
B-scan	92, 94	
Babinet's theorem	171	
Bacteria	73	
Band gap	55, 125, 151	
Band structure	68	
Band theory	55, 125, 126, 151	
Band-pass filter	139	
Bandwidth	135, 139	
Barometric height formula	33, 200	
Beam angle	95	
Beam density	166	
Beam hardening	86, 89	
Beam intensity in relation to power and voltage	89	
Bernoulli's equation: Hagen-Poiseuille law	35	
Biot-Savart's law	118	
Birefringence	189	
Black body radiation	159	
Blood cells	73	
Bode diagram	138	
Bohr model	66, 213	
Boiling point	51, 145, 146	
Boyle and Mariotte's law	148	
Bragg equation	63, 209	
Bragg scattering	61, 62, 83, 207	
Bravais lattice	63, 83, 209	
Bremsstrahlung	64, 65, 66, 82	
Brewster angle	189	
Brewster's law	168	
Brillouin zone	68, 103	
Butterfly wing	73	
C		
Calorimetry	163	
Capacitance	116, 122, 135, 138	
Capacitance of a plate capacitor	57, 113, 153	
Capacitor	113, 114, 115, 135	
Carbon film resistor	53, 112, 151	
Centre of gravity	22	
Centrifugal force	29	
Chaotic oscillation	140	
Characteristic frequency	24	
Characteristic impedance	139	
Characteristic radiation	82	
Characteristic X-radiation	61, 62, 63, 64	
Characteristic X-rays	83	
Charge	162	
Charge carrier generation	53, 112, 151	
Charge carriers	54, 124	
Charge density	68, 103	
Charging	114, 115, 152	
Charging capacitor	136	
Charles's (Amontons') law	148	
Chladni figures	104	
Circuit	134, 138	
Circular motion	20	
Circularly and elliptically polarised light	167	
Coefficient of thermal conductivity	144	
Coefficient of thermal expansion	148	
Coercive field strength	47	
Coherence	106, 170, 171, 178	
Coherent and incoherent photon scattering	65, 84, 85, 211	
Coherent light	172	
Coil	47, 120, 123, 135	
Collector equations	160	
Collision of second type	189	
Commensurability	68	
Compressibility	38	
Compressor	155	
Compton	61, 62, 63, 64	
Computed tomography	86	
Condensation	155	
Conduction band	55, 111, 125, 126	
Conduction of heat	160	
Conductivity	55, 125, 129, 131	
Conductivity of water samples	195	
Conductor	134	
Constant-Mode	69	
Constant-Height and Constant- Mode	68, 70, 103	
Contact resistance	131, 133	
Contamination by inorganic salts	195	
Continuity equation	35	
Continuous measurement	36	
Convection	156, 160	
Conversion of heat	158	
Cooling capacity	156	
Coplanar forces	16	
Corner echo	94	
Coulometry	162	
Couple	16	
Critical or optimum coupling	139	
Critical point	32	
Crystal classes	63, 209	
Crystal lattices	62, 63, 83, 208	
Crystal structures	61, 207	
Crystal systems	62, 63, 83, 208	
CT table	88	
Cubic compressibility coefficient	148	
D		
Damage to forests	196	
Damped oscillation	121	
Damped/ undamped free oscillation	24	
Damping	135	
Damping constant	24	
Damping of ultrasonic (scattering, reflection,....)	97	
Daniell cell	128	
De Broglie relationship	169	
Debye temperature	51, 145, 146	
Debye-Scherrer	61, 62, 83, 207	
Decomposition voltage	164	
Defect electrons	54, 124	
Deformation	14	
Degree of freedom	145	
Degree of polarisation	168	
Density	38	
Density of liquids	28	
Detector dark current	89	
Developing of film	106, 187, 188	
Dielectric constant	57, 113, 153	
Dielectric displacement	57, 113, 153	
Dielectric polarisation	57, 113, 153	
Differentiating network	137	
Diffraction	106, 169, 187, 188	
Diffraction index	48, 105, 180, 181	
Diffraction of light	170	
Diffraction uncertainty	169	
Diffractionmetry	61, 62, 83, 207	
Diffuse emission and reflection	166	
Diffusion	52, 143	
Diffusion potential	161	
Digital imaging	82	
Diode	136, 140	
Diode laser	190, 192	
Direct energy conversion	130, 157	
Direct imaging sensor	88	
Discharging	114, 115, 152	
Discontinuity	95	
Dissipation factor	139	
Donors	111, 151, 161	
Doppler effect	34, 35, 41, 177	
Doppler shift of frequency	41, 42	
Doppler sonography	35	
Double	167	
Drinking water	195	
Du Nouy method	32	
Ductility	77	
Dulong Petit's law	51, 145, 146	

Dynamic and kinematic viscosity	31
Dynamic force mode	74, 102
Dynamic mode	72, 73, 75, 102
E	
Echo amplitude	91
Edge absorption	65, 84, 211
Efficiency	130, 157, 158, 160
Efficiency rating	156
Eigen-modes	104
Elastic after-effect	19
Elastic hysteresis	19
Elasticity	15
Electric constant	57, 113, 153
Electric field	113, 153
Electrical conductivity	52, 143
Electrical eddy field	120
Electrochemical cells	127, 153
Electrochemical potential	128
Electrode polarisation	129, 164
Electrode potentials and their concentration...	127, 153
Electrode reactions	128
Electrolysis	129, 162, 164
Electrolytes waste water	195
Electromagnetic field interaction	174
Electromagnetic theory of light	168
Electromagnetism	56, 174
Electromotive force	128
Electron oscillation	174
Electronic oscillation	56, 174
Electrons	54, 124
Eluvation	195
Energie dispersive measurement	63, 64, 65, 84
Energy dispersive	65, 211
Energy ceiling	160
Energy detectors	66, 84, 214
Energy level	61, 64, 65, 66
Energy-band diagram	111, 151, 161
Enthalpy of combustion	149, 150
Enthalpy of formation	150, 163
Enthalpy of reaction	163
Eötvös equation	32
Equation of state	33, 200
Equation of state for ideal gases	145
Equilibrium	16, 29
Equilibrium spacing	50
Equipotential lines	113, 153
Etching	78
Evaporation	28
Exponential function	114, 115, 152
Extension and compression	19
Extrinsic conduction	55, 125, 126
Extrinsic conductivity	55, 125, 151
F	
Fabry-Perot Etalon	189
Fabry-Perot interferometer	185, 186
Far field	99
Faraday effect	56, 174
Faraday's law	162
Faraday's constant	162
Faraday's law	164
Feedback loop	67, 72, 73, 102
Fermi characteristic energy level	161
Ferromagnetic material	48, 181
Fiber textures	83
Filter	138
Filtration	89
First and second law of thermodynamics	158
First law of thermodynamics	145, 147, 149, 150
Flaw detection	91
Flow measurement	35
Fluidity	31
Fluorescence	61, 62, 63, 64
Fluorescent screen	82
Fluorescent yield	64, 65, 66, 84
Fog technique	176
Forbidden band	126
Forbidden zone	55, 125, 151
Force-distance measurements	74, 102
Forced cooling	156
Forced oscillation	24, 140
Four-point measurement	52, 143
Four-wire method of measurement	131, 133
Fourier filtering	68, 103
Fourier spectrum	140
Fourier transform	175, 176
Fraunhofer	170, 175, 176
Fraunhofer and Fresnel	171
Fraunhofer interference	171
Free charges	57, 113, 153
Free path	53, 112, 151
Frequency	37, 38, 40, 96
Frequency doubling	191
Frequency shift	35
Fresnel's equations	168
Full-wave rectifier	136

G	
G-modulus	17, 45
Galvanic elements	164
Gas chromatography	144
Gas constant	33, 200
Gas discharge tube	189
Gas laws	158
Gaseous and aerosol emissions	196
Gaussian beam	192
Gay-Lussac's law	148
General equation of state for ideal gases	162
Generation of onshore and offshore winds	194
Goniometer	212
Graetz rectifier	136
Greenhouse effect	160
Greyscale display	92
Grinding	77
Grüneisen equation	50
H	
Half life	114, 115, 152
Half-shade principle	173
Half-wave rectifier	136
Hall coefficient	54, 55, 124, 125
Hall effect	118, 174
Hall mobility	54, 124
Heat capacity	51, 145, 146, 150
Heat conduction	154, 156
Heat of combustion	149
Heat of reaction	149
Heat pipe	156
Heat radiation	160, 194
Heat transfer	154
Heat transition	154
Heating capacity	156
Heisenberg's uncertainty principle	169
Hess' law of constant heat summation	150
Hexagonal Structures	68, 70, 103
High- and low-pass filters	34, 177
High-pass	137, 138
Holography	188
Hooke's law	14, 15, 19
Hooke's law oscillations	23
Horizontal/vertical zones	195
Hothouse effect	154
Human hair	73
Huygens' principle	99, 170, 171, 175
Hydrogen bond	28
Hydrophone	99
I	
Ideal gas law	148
Illuminance	166
Image artefacts	92
Imaging at the liquid-solid interface	69
Imaging of biological samples	73
Imaging of magnetic nano structures	49, 76, 102
Imaging on the subnanometer scale	68, 69, 70, 103
Impedance	122, 134
Implant model	82
Impulse of sound	39
Impurity depletion	126
Incident angle	93
Incommensurability	68
Index of	175, 176, 179
Induced emission	190, 191
Induced voltage	120
Inductance	117, 135, 138
Induction	47, 118, 123, 152
Induction law	132
Inductive and capacitive reactance	134
Initial echo	36
Inorganic fertilisers	201
Integrating network	137
Interaction of electromagnetic fields	56, 174
Interaction of molecules	69
Interface	32, 100
Interference	34, 48, 99, 105
Interference at thin layers	172
Interference in thin films	172
Internal energy	51, 145, 146
Internal friction	30
Internal resistance	136, 161
Intrinsic conduction	55, 125, 126
Intrinsic conductivity	55, 125, 151
Inverse square law	89
Inversion	189, 190, 191
Ionising radiation	83
Isobars	145
Isochoric and isothermal changes	158
Isochors and adiabatic changes of state	145
Isotherms	145
J	
Joule effect	156
K	
K-Space	68, 103

10 Indices

10.2 Alphabetical index

Kinetic gas theory	33, 200
Kirchhoff's formula	169
Kirchhoff's laws	116, 117, 132, 134
Kundt's Tube	40
L	
Lambert's law	166
Laminar and turbulent flow	35
Laser	34, 171, 177, 189
Lattice	61, 62, 83, 207
Lattice potential	50
Lattice vibration	51, 145, 146
Laue	61, 62, 83, 207
Laue method	63, 209
Law of	168
Law of absorption	82, 85
Law of coherence	170
Law of Fraunhofer and Fresnel	170
Law of Huygens' principle	170
Law of induction	119
Law of interference	170
Law of laser	170
Laws of Gyroscopes	25, 26
Layer-thickness	63, 64, 65, 84
Lennard-Jones Potential	72, 74, 102
Lenses	175, 176
Lenz's law	121
Lever	16
Light velocity	178, 179
Limit of elasticity	19, 23
Limit value monitoring	36
Linear expansion	50
Linearly	167
Lippich polarizer	173
Littrow prism	189
Loaded transformer	123, 152
Local Density Of States (LDOS)	68, 70, 103
Logarithmic decrement	121
Longitudinal	38, 39, 40, 42
Longitudinal and transverse	44, 98
Lorentz force	55, 125, 151
Lorentz transformation	182
Lorenz number	52, 143
Loss resistance	135
Low-pass	137, 138
Luminance	166
Luminous flux	166
Luminous intensity	166
M	
Mach-Zehnder interferometer	183
Magnetic data storage	49, 76, 102
Magnetic field	118
Magnetic field of coils	47, 120
Magnetic field strength	47
Magnetic flux	47, 119, 120, 123
Magnetic flux density	118
Magnetic Force Microscopy (MFM)	49, 76, 102
Magnetic forces	49, 76, 102
Magnetic resistance	55, 125, 151
Malus' law	56, 167, 173, 174
Mass absorption coefficient	82
Mass attenuation coefficient	85
Material contrast	75, 102
Mathie's rule	53, 112, 151
Matrix effects	65, 66, 84, 85
Maxwell equations	57, 113, 116, 117
Mean lifetime of a metastable state	190
Measure	83
Measurement accuracy	169
Mechanical equivalent of heat	147
Mechanical force	74, 102
Mechanical hysteresis	15
Mechanical scanner	100
Mechanical work	147
Melting	28
Metal microscopy	78
Metallic film resistor	53, 112, 151
Metallographic phases	78
Metallographic preparation	77
Metals	52, 143
Michelson interferometer	48, 105, 178, 179
Micrography	78
Miller indices	61, 62, 63, 83
Mixture temperature	51, 145, 146
Mobility	55, 125, 151
Modulus of elasticity	14, 17, 44, 45
Mohr balance	28
Mole volumes	145
Moment	21
Moment of inertia	17, 20, 21, 22
Moments	16
Monochromatization of X-rays	83
Monomode and multimode fibre	192
Moseley's law	66, 213
Multi-channel analysers	63, 64, 65, 66
Multiple beam interference	171
Multiple reflections	36

N	
Nano imaging	72, 73, 102
Nano magnetics	49, 76, 102
Nano mechanics	74, 102
Nanomorphology	67
Nanotechnology	67
Natural frequency	40
Near-field length	99
Nernst equation	127, 128, 153
Newton's colour glass	172
Newton's laws	20
Newton's ring apparatus	172
Newtonian liquid	30, 31
Neyer-Neldel Rule	55, 125
Non-destructive testing (NDT)	91, 94
Normal Hall effect	54, 124
NTC	53, 112, 151
Numerical aperture	192
Nutation	25, 26

O	
Object beam	106, 187, 188
Ohm's law	129, 131, 133
Ohmic resistance	134
Operating point	111, 151
Optic axis	167
Optical activity	173
Optical path length	188
Optical pumping	190, 191
Optical resonator	191
Optical rotatory power	173
Ordinary and extraordinary ray	167
Origin of climatic fluctuations	194
Oscillating circuit	121, 140
Oscilloscope	158

P	
p-n junction	111, 151, 161
Paraboloid of rotation	29
Parallel conductance	139
Parallel connection	132, 134
Parallel springs	23
Parallel-T filters	137
Parallel-tuned circuit	135
Path difference	172
Pauli method	139
Peierl's Theorem	68
Peierl's Transition	68
Peltier coefficient	130, 156, 157
Peltier effect	156
PEM electrolyser	164
PEM fuel cell	164
Period multiples	140
Periodic structures	68, 103
pH value	202
Phase	48, 105, 178, 179
Phase contrast imaging	49, 75, 76, 102
Phase difference	188
Phase displacement	116, 117, 135, 138
Phase holograms	106, 187, 188
Phase relationship	172
Phase relationshipship	172
Phase shift	75, 102, 122
Phasor diagram	122
Photo-conductive effect	161
Piezo-electric devices	68, 70, 103
Piezoelectric effect	38
Piezoelectric ultrasonic transducer	38
Piezoelectric ultrasonics transformer	38
Plane of polarization	167
Plane of polarization of polarization	167
Plastic flow	15
Plasticity	15, 30
Point Defects	68, 103
Poisson's ratio	14
Poisson's spot	171
Polarimetry	173
Polarisation	56, 168, 174, 191
Polarisation level	168
Polariser	167
Polishing	77
Polychromaticity	89
Polymers	75, 102
Potential	113, 153
Potentiometer	132
Powder diffractometry	61, 62, 83, 207
Precession	25, 26
Preferential corrosion measurement	94
Pressure	33, 148, 200
Probe delay	90
Propagation of sound	42
Propagation of ultrasound	44, 90, 91, 97
Proton-Exchange-Membrane (PEM)	164
PTC	53, 112, 151
Q	
Q factor	121, 135, 139

Qualitative analysis	63, 64, 65, 84
Quantity of light	166
Quantum mechanics	184
Quenching gas	83
R	
r.m.s. value	136
Radiography	82
Rainwater	195
Ratio of attenuation/ decrement	24
Reaction rate	173
Real and virtual image	106, 187, 188
Real charges	57, 113, 153
Reciprocal lattice	61, 62, 63, 68
Redox electrodes	127, 153
Reference beam	106, 187, 188
Reflection	93, 95
Reflection coefficient	91, 92, 168
Reflection factor	168
Refraction index	178, 179, 188
Refrigerator	155
Relaxation	15, 190, 191
Remanence	47
Resistance	132, 134, 135, 138
Resistivity	131, 133
Resolution	92, 100, 101
Resonance	121, 139
Resonance frequency	24
Resonance shift	49, 76, 102
Resonator cavity	189
Resonator modes	191
Restrictor valve	155
Reveal crystallographic structure	78
Reversible cycles	158
Rigid body	22
Ripple	136
Ripple voltage	136
River water	195
RLC	135
Rotary motion	21, 29
Rotating liquids	29
Rotating tabel	88
Rotation	20, 21
Rotation table	88
Rotational energy	21
Rydberg frequency	66, 213
S	
Saccharimetry	173
Salinity	201
Sampling theorem	34, 177
Saturation thickness	85
Scanning Tunneling Microscopy (STM)	67, 68, 69, 70
Scanning Tunneling Microscopy (STM) and Spectroscopy	68
Scattering	35
Scattering of light by small particles (Mie...)	34, 177
Scattering of X-rays	66, 84, 214
Screening constant	66, 213
Seebeck coefficient	130, 156, 157
Seebeck effect (thermoelectric effect)	130, 157
Self assembled monolayers (SAM)	69
Self-assembly of molecules	69
Self-inductance	121, 122
Semiconductor	55, 66, 84, 85
Semiconductor energy detectors	64, 65, 66, 84
Serial springs	23
Series connection	132, 134
Series-tuned circuit	135
Shear	44, 93, 98
Shear (transverse)	94
Shear modulus	17, 45
Shear stress	30
Sheet textures	83
Signal-to-noise ratio	95
Single crystal	61, 62, 83, 207
Skin cross section	73
Skip distance	93
Slope efficiency	192
Smoothing factor	136
Soil horizon	202
Solar cell	161
Solar ray collector	160
Solenoids	121
Solubility	66, 84, 212, 214
Solubility product	66, 84, 212, 214
Sound pressure	37
Sound velocity	36, 44, 90, 92
Sound velocity in gases	40
Sound wave	39
Special relativity theory	182
Specific heat	52, 143
Specific irradiance	166
Specific rotation	173
Specific thermal capacity	147
Spectral power density	34, 177
Spectroscopy	63, 64, 65, 84
Spectrum	89
Speed of light	48, 105, 180, 181

Spin-orbit coupling	48, 181
SPM	67
Spontaneous and stimulated light emission	189
Spontaneous emission	190, 191
Spring constant	19, 22, 23
Square wave	137
Static force mode	74, 102
Static mode	72, 102
Statics	16
Stationary	37, 40, 104
Stefan-Boltzmann's law	159
Step Edges	68, 103
Step response	137
Stereographic projection	82
Stiffness	74, 102
Stirling engine	158
STM	67, 68
Stokes' law	31
Straight beam probe	95
Stress	14
Structure amplitude	62, 63, 208, 209
Structure analysis	61, 62, 83, 207
Structure factor	61, 83, 207
Substratum	202
Superimposition of sound	42
Surface chemistry	67
Surface energy	32
Surface physics	67
Surface tension	32
Sweep	139

T	
Temperature	33, 53, 112, 148
Temperature amplitude attenuation	154
Temperature dependence of resistances	159
Temperature gradient heat transport	52, 143
Temporal coherence	182
Thermal capacity	50, 147, 154
Thermal conductivity	144
Thermal energy	147
Thermal expansion	50
Thermal pump	158
Thermal radiation	154
Thermal tension coefficient	148
Thermal-conductivity detector	144
Thermochemistry	163
Thermoelectric converter	130, 156
Thermoelectric e.m.f.	130, 156, 157, 159
Thickness measurement	90
Thomson coefficient	130, 156, 157
Thomson equations	130, 156, 157
Threshold energy	192
Time constant	114, 115, 152
Time of flight	91
Time of flight	36, 90, 97
TOFD method (time of flight)	94
Tomography	88, 101
Torque	15, 17, 21, 25
Torque and restoring torque	24
Torsion modulus	15
Torsion pendulum	24
Torsional vibration	22, 24
Torsional vibrations and torsion modulus	17, 45
Total reflection	192
Transfer function	137
Transformer	121, 123, 152
Transistor	111, 151
Transit time	192
Transition Metal Chalcogenide	68
Transmission coefficient	97
Transverse and longitudinal modes	192
Transverse and longitudinal resonator modes	189
Tunneling effect	67, 68, 69, 70
Turbulence	34, 177
Two-beam interferometer	186
Two-dimensional standing	104

U	
Ultrasonic	37, 38, 42
Ultrasonic	44, 91, 93, 94
Ultrasonic Doppler effect	35
Ultrasonic echography	90, 91, 92, 93
Ultrasonic echography (A-Scan)	96, 100, 101
Ultrasonic imaging (B-Scan)	96
Ultrasound wave modes	44, 98
Uncertainty of location	169
Uncertainty of momentum	169
Universal gas constant	145, 148
Unloaded transformer	123, 152

V	
Valence band	55, 111, 125, 126
Vaporisation	155
Vaporisation enthalpy	155
Vapour pressure	155
Velocity gradient	30
Velocity of light	178, 192
Velocity of sound	40

10 Indices

10.2 Alphabetical index

Velocity of sound in liquids	37, 38
Verdet's constant	56, 174
Vibration Amplitude	49, 72, 75, 76
Virtual light source	48, 105, 178, 179
Viscosity	30
Viscosity and fluidity	35
Viscosity measurements	31
Voltage	113, 132, 134, 153
Voltage doubling	136
Voltage stabilisation	136
Volume	148
Volume expansion	28
Volume expansion of liquids	50
W	
Water anomaly	28
Wave interference	184
Wave length	37, 38, 40, 48
Wave propagation	39, 41
Wave-particle dualism	169
Wave-particle duality	184
Weber-Fechner law	173
Weiss molecular magnetic fields	48, 181
Wheatstone bridge	134
Wiedmann-Franz law	52, 143
Wien-Robinson bridge	137
Wire loop	118
X	
X-ray	61, 62, 63, 64
X-ray apparatus	212
X-ray camera	88
X-ray energy detector	63, 64, 65, 84
X-ray expert unit	61, 62, 63, 64
X-ray fluorescence analysis	63, 64, 65, 84
X-ray photography	82
XR 4.0	88
XRED	65, 211
XRT	88
Y	
Young's modulus	14
Z	
Z diode	53, 112, 151
Zener effect	53, 112, 151
Zone of focus	92, 99

Your solution

with just one click!

Our comprehensive website www.phywe.com provides you with all the information you need to cover the full spectrum of solutions and products from PHYWE – in five languages! Whether your specific needs involve physics, chemistry, biology or applied sciences, and whether you are looking for information relating to school or university-level materials, you can always find just the right products there quickly and easily.

Further highlights on our website include:

- More than **50 product movies**
- Complete assembly instructions in video form
- Up-to-date software downloads
- **Free-of-charge descriptions of the experiments**
- Operating manuals and instruction sheets to download
- Complete list of equipment



- 1 Language
- 2 Subject area = Physics, Chemistry, Biology, Applied Sciences
- 3 Education level = School, University
- 4 Media e. g. product videos
- 5 Downloads e. g. experimental literature

Visit us today: www.phywe.com



Global network

Your partner is never far away!

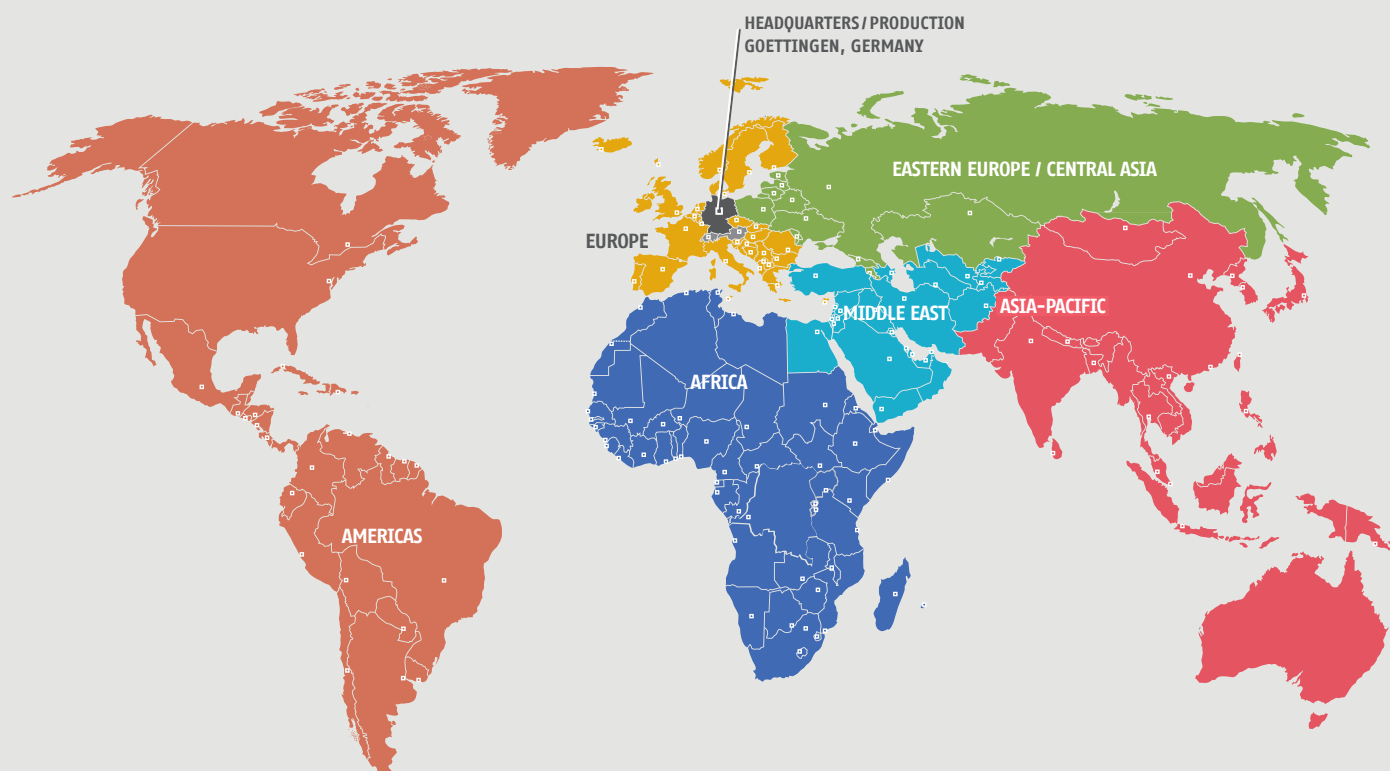

Our worldwide presence enables us to offer you customised local solutions. More than 145,000 customers in over 95 countries appreciate our experience and reliability, our high technical standards, and the ease and clarity with which our innovative products can be operated.

Are you looking for a partner near your location?

Please do not hesitate to call us. We would be pleased to assign you a personal contact.

■ **HEADQUARTERS / PRODUCTION**
PHYWE Systeme GmbH & Co. KG
Robert-Bosch-Breite 10
D-37079 Göttingen
Germany
P. +49 (0) 551 604-0
F. +49 (0) 551 604-107
info@phywe.com

■ **AMERICAS**
P. +49 (0) 551 604-119
F. +49 (0) 551 604-115
america@phywe.com

■ **AFRICA**
P. +49 (0) 551 604-323
F. +49 (0) 551 604-115
africa@phywe.com

■ **EUROPE**
P. +49 (0) 551 604-254
F. +49 (0) 551 604-115
we@phywe.com

■ **EASTERN EUROPE / CENTRAL ASIA**
P. +49 (0) 551 604-233
F. +49 (0) 551 604-115
oe@phywe.com

■ **MIDDLE EAST**
P. +49 (0) 551 604-222
F. +49 (0) 551 604-115
nmo@phywe.com

■ **ASIA-PACIFIC**
P. +49 (0) 551 604-245
F. +49 (0) 551 604-115
asia@phywe.com

Worldclass solutions
for better education:
www.phywe.com

PHYWE

excellence in science

PHYWE Systeme GmbH & Co. KG
Robert-Bosch-Breite 10
37079 Göttingen / Germany

P. +49 (0) 551 604 - 0
F. +49 (0) 551 604 - 107

info@phywe.com



Our International Sales Partner



More than 600 experiments

Find more University Experiments in our special catalogues Physics, Chemistry, Biology, Engineering and Medicine.

